











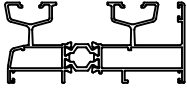
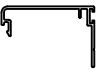
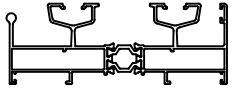
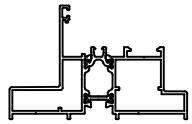
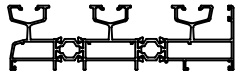

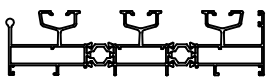

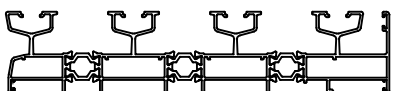

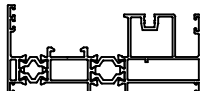
**SL40T - 1,4mm**

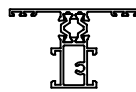
ISI YALITIMLI SÜRME SİSTEM  
THERMAL SLIDING SYSTEM

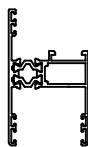

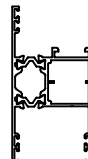
**PROFİL VE AKSESUAR LİSTELERİ**  
***PROFILE & ACCESSORIES LISTS***

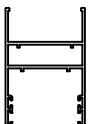







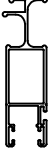

## PROFİL LİSTESİ - PROFILES LIST

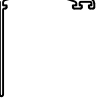
SL40T 01			SL40T 41		
KASA PROFİLİ FRAME PROFILE	AĞIRLIK / Weight 1,676 kg/mt		KENET PROFİLİ CENTRAL LOCKING PROFILE	AĞIRLIK / Weight 0,372 kg/mt	
SL40T 02			SL38T 55		
KASA PROFİLİ FRAME PROFILE	AĞIRLIK / Weight 1,968 kg/mt		TH55 SİSTEM GEÇİŞ KASA PROFİLİ FRAME PROFILE FOR TH55	AĞIRLIK / Weight 1,613 kg/mt	
SL40T 03			SL40T 42		
3 LÜ KASA PROFİLİ FRAME PROFILE	AĞIRLIK / Weight 2,569 kg/mt		ADAPTÖR PROFİLİ ADAPTER PROFILE	AĞIRLIK / Weight 0,738 kg/mt	
SL40T 05			SL40 81		
3 LÜ KASA PROFİLİ FRAME PROFILE	AĞIRLIK / Weight 2,862 kg/mt		KASA KAPAK PROFİLİ FRAME COVER PROFILE	AĞIRLIK / Weight 0,572 kg/mt	
SL40T 06			SL40 82		
4 LÜ KASA PROFİLİ FRAME PROFILE	AĞIRLIK / Weight 3,467 kg/mt		KASA KAPAK PROFİLİ FRAME COVER PROFILE	AĞIRLIK / Weight 0,588 kg/mt	
SL40T 04			SL40 72		
SABİTLİ KASA PROFİLİ FRAME PROFILE	AĞIRLIK / Weight 1,933 kg/mt		SABİT PANJUR LAMELİ SHUTTER BLIND	AĞIRLIK / Weight 0,986 kg/mt	
SL40T 21			SL40 73		
ORTA KAYIT PROFİLİ TRANSOM-MULLION PROFILE	AĞIRLIK / Weight 1,004 kg/mt		LAMEL ADAPTÖR PROFİLİ SHUTTER ADAPTER PROFILE	AĞIRLIK / Weight 0,245 kg/mt	
SL40T 11			LS60 71		
Jx cm <sup>4</sup>	Jy cm <sup>4</sup>		KULP PROFİLİ HANDLE PROFILE	AĞIRLIK / Weight 2,050 kg/mt	
KANAT PROFİLİ SASH PROFILE	AĞIRLIK / Weight 1,092 kg/mt				
SL40T 12			LS60 72		
Jx cm <sup>4</sup>	Jy cm <sup>4</sup>		KULP KAPAK PROFİLİ HANDLE COVER PROFILE	AĞIRLIK / Weight 0,420 kg/mt	
GENİŞ KANAT PROFİLİ SASH PROFILE	AĞIRLIK / Weight 1,318 kg/mt				
SL40 13			15-304216-09		
Jx cm <sup>4</sup>	Jy cm <sup>4</sup>		SİNEKLİK KANAT PROFİLİ FLYSCREEN SASH PROFILE	AĞIRLIK / Weight 0,352 kg/mt	
SABİT PANJUR KANAT PROFİLİ SHUTTER SASH PROFILE	AĞIRLIK / Weight 0,865 kg/mt				

\* Sipariş öncesi kalıp bilgisi kontrol edilmeli / must be check profile mold before the order

Profil ağırlıklarımız teorik olup; teslim anındaki tartımız geçerlidir

## PROF L L STES - PROFILES LIST

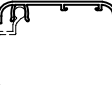
15-306317-11			12-53		
S NEKL K KANAT PROF L FLYSCREEN SASH PROFILE	A IRLIK / Weight 0,561 kg/mt		PERVAZ MONTAJ PROF L BORDER FIXING PROFILE	A IRLIK / Weight 0,177 kg/mt	
12-61			12-54		
RAY PROF L RAILE PROFILE	A IRLIK / Weight 0,111 kg/mt		PERVAZ PROF L BORDER PROFILE	A IRLIK / Weight 0,326 kg/mt	
SL40 61					
"U" T P RAY PROF L RAILE PROFILE TYPE "U"	A IRLIK / Weight 0,148 kg/mt				
SL40 62					
"V" T P RAY PROF L RAILE PROFILE TYPE "V"	A IRLIK / Weight 0,134 kg/mt				
SL40 63					
RAY YUVA PROF L RAILE GROOVE PROFILE	A IRLIK / Weight 0,140 kg/mt				
SL40 35					
KANAT SABİTLEME PROFİLİ SASH FIXING PROFILE	A IRLIK / Weight 0,494 kg/mt				
SL40 44					
KASA KANAL PROFİLİ (mat siyah - black painted) FRAME CHANNEL PROFILE	A IRLIK / Weight 0,160 kg/mt				
SL40 45					
KASA B RLE M PROF L FRAME JOINT PROFILE	A IRLIK / Weight 0,114 kg/mt				
SL40 64					
S NEKL K RAY PROF L FLYSCREEN RAILE PROFILE	A IRLIK / Weight 0,478 kg/mt				
12-52					
PERVAZ PROF L BORDER PROFILE	A IRLIK / Weight 0,279 kg/mt				

















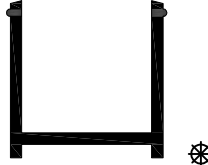

\* Sipariş öncesi kalıp bilgisi kontrol edilmeli / must be check profile mold before the order

Profil a ırlıklarımız teorik olup; teslim anındaki tartımız geçerlidir

## PROF L L STES - PROFILES LIST

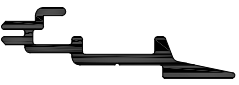
11-004				
CAM ÇİTASI-4 mm GLAZING BEAD PROFILE	A IRLIK / Weight 0,181 kg/mt			
11-006				
CAM ÇİTASI-6 mm GLAZING BEAD PROFILE	A IRLIK / Weight 0,218 kg/mt			
11-010				
CAM ÇİTASI-10 mm GLAZING BEAD PROFILE	A IRLIK / Weight 0,233 kg/mt			
11-015				
CAM ÇİTASI-15 mm GLAZING BEAD PROFILE	A IRLIK / Weight 0,241 kg/mt			
11-017				
CAM ÇİTASI-17 mm GLAZING BEAD PROFILE	A IRLIK / Weight 0,250 kg/mt			
11-020				
CAM ÇİTASI-20 mm GLAZING BEAD PROFILE	A IRLIK / Weight 0,276 kg/mt			
11-022				
CAM ÇİTASI-22 mm GLAZING BEAD PROFILE	A IRLIK / Weight 0,282 kg/mt			
11-026				
CAM ÇİTASI-26 mm GLAZING BEAD PROFILE	A IRLIK / Weight 0,296 kg/mt			
10-010106-00				
KÖ E TAKOZU-10,6 mm CORNER JOINT	A IRLIK / Weight 2,653 kg/mt			
10-010225-00				
KÖ E TAKOZU-22,5 mm CORNER JOINT	A IRLIK / Weight 3,566 kg/mt			





## AKSESUAR L STES - ACCESSORIES LIST

EP1-01			ASI-SFP 01		
DI CAM F T L - 2,5 mm OUTER GLAZING GASKET	KOL M KTARI/Package 240 mt / 15 kg		HAVA KES C - ALT/ÜST CENTRAL SEALING TOP / BOTTOM	KOL M KTARI/Package Adet / Piece	
EP2-01			ASI-SFP 02		
Ç CAM F T L - 3 mm INNER GLAZING GASKET	KOL M KTARI/Package 440 mt / 15 kg		HAVA KES C - ALT/ÜST (SL40T 04 KASA Ç N) CENTRAL SEALING TOP / BOTTOM - FOR SL40T 04	KOL M KTARI/Package Adet / Piece	
EP2-02			SL40-PLU 01		
Ç CAM F T L - 4 mm INNER GLAZING GASKET	KOL M KTARI/Package 300 mt / 15 kg		KASA KANAL PVC FRAME PVC CHANNEL	KOL M KTARI/Package 6 mt / Adet	
EP2-03			SL40-PLU 02		
Ç CAM F T L - 5 mm INNER GLAZING GASKET	KOL M KTARI/Package 250 mt / 15 kg		KASA KANAL PVC (SL40T 04 KASA Ç N) FRAME PVC CHANNEL FOR SL40T 04	KOL M KTARI/Package 6 mt / Adet	
SKF-01			SL40-STP		
SÜRME KAPATMA F T L SLIDING GASKET	KOL M KTARI/Package 265 mt / 15 kg		KANAT GÜVENL K PLAST ANTI-LIFT DEVICE	KOL M KTARI/Package Adet / Piece	
INT1-03			SL40-KNL		
CAM F T L - 10mm GLASS GASKET - 10mm	KOL M KTARI/Package 500 mt / 15 kg		SPANYOLET K L TLEME PVC ADAPTÖR MULTI POINT LOCK ADAPTER	KOL M KTARI/Package Adet / Piece	
KF 67-700			SL40-KLF		
FIRÇA F T L - 7mm BRUSH GASKET	KOL M KTARI/Package 1200 mt		RULMAN ADAPTÖR PVC ROLLER PVC ADAPTER	KOL M KTARI/Package Adet / Piece	
ASI-5025			SL40-KP02		
S NEKL K F T L FLYSCREEN GASKET	KOL M KTARI/Package 100 mt		4 LÜ KANAT K L TLEME ADAPTÖR KAPA I MEETING STILE CAP	KOL M KTARI/Package Adet / Piece	
SL40-PLZ 01			ASI-STP 03		
KENET PVC PROFIL (SL40T 11 İÇİN) FRAME PVC CHANNEL FOR SL40T 11	KOL M KTARI/Package 6 mt / Adet		KANAT STOPER SASH STOPPER	KOL M KTARI/Package Adet / Piece	
SL40-PLZ 02			SL40-KP01		
KENET PVC PROFIL (SL40T 12 İÇİN) FRAME PVC CHANNEL FOR SL40T 12	KOL M KTARI/Package 6 mt / Adet		KENET KAPA I-ALT/ÜST INTERLOCK PROFILE CAP TOP / BOTTOM	KOL M KTARI/Package Adet / Piece	

## AKSESUAR LİSTES - ACCESSORIES LIST

MO60-19			ASI-SH 007K		
KOL PROFİL KAPAKI HANDLE PROFILE CAP	KOL MİKTARI/Package alt-üst takım / set		HAVUZ KİLİT KARŞILIK (ASI-SH 007 ve 007A için) EMBEDED HANDLE STRIKE HOOK FOR ASI-SH 007/007A	KOL MİKTARI/Package Takım / Set	
ASI-SR 01			ASI-SH 005		
AYARLI TEKLİ RULMAN (V T P RAY ÇİFTİ) SINGLE SLIDING ROLLER FOR RAIL TYPE - V	KOL MİKTARI/Package Adet / Piece		SÜRME ÇEKME KOL PULL HANDLE	KOL MİKTARI/Package Adet / Piece	
ASI-SR 02			ASI-ISP15.0		
AYARLI ÇİFTLİ RULMAN (V T P RAY ÇİFTİ) DOUBLE SLIDING ROLLER FOR RAIL TYPE - V	KOL MİKTARI/Package Adet / Piece		İSPANYOLET KİLİTLEME (400mm) MULTI POINT LOCK	KOL MİKTARI/Package Adet / Piece	
ASI-SR 02R			ASI-ISP15.1		
AYARLI ÇİFTLİ RULMAN (U T P RAY ÇİFTİ) DOUBLE SLIDING ROLLER FOR RAIL TYPE - U	KOL MİKTARI/Package Adet / Piece		İSPANYOLET KİLİTLEME (600mm) MULTI POINT LOCK	KOL MİKTARI/Package Adet / Piece	
ASI-SR 05R			ASI-ISP15.2		
AYARLI ÇİFTLİ RULMAN (U TİPİ RAY İÇİN)80+80kg DOUBLE SLIDING ROLLER FOR RAIL TYPE - U	KOL MİKTARI/Package Adet / Piece		İSPANYOLET KİLİTLEME (1000mm) MULTI POINT LOCK	KOL MİKTARI/Package Adet / Piece	
ASI-BZ 5060			ASI-ISP15.3		
S NEKLİK KANAT RULMAN FLYSCREEN SASH ROLLER	KOL MİKTARI/Package Adet / Piece		İSPANYOLET KİLİTLEME (1800mm) MULTI POINT LOCK	KOL MİKTARI/Package Adet / Piece	
ASI-INR 01			ASI-ISP K03		
ÇELİK RAY STEEL RAIL	KOL MİKTARI/Package 3,5 mt / Adet		İSPANYOLET KİLİT KARŞILIK MULTI POINT LOCK STRIKER	KOL MİKTARI/Package Adet / Piece	
ASI-SH 007			ASI-WH 002		
HAVUZ KOL EMBEDED HANDLE	KOL MİKTARI/Package Adet / Piece		İSPANYOLET KİLİTLEME KOL MULTI POINT LOCK HANDLE	KOL MİKTARI/Package Adet / Piece	
ASI-SH 007A			ASI-WH 006		
KİLİTLİ HAVUZ KOL EMBEDED HANDLE WITH LOCK	KOL MİKTARI/Package Adet / Piece		GÖMME İSPANYOLET KİLİTLEME KOL EMBEDED HANDLE FOR MULTI POINT LOCK	KOL MİKTARI/Package Adet / Piece	
ASI-SH 007B			SL40-DB 3570		
ÇEKME HAVUZ KOL PULL EMBEDDED HANDLE	KOL MİKTARI/Package Adet / Piece		KANAT SABİTLEME PARÇASI SASH FIXING	KOL MİKTARI/Package Adet / Piece	

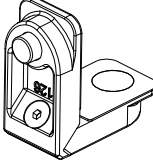
## AKSESUAR LİSTESİ - ACCESSORIES LIST

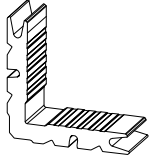
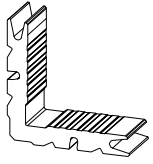
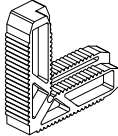
<b>ASI-SB 19</b>				
KÖŞE GÖNYESİ CORNER ALIGNMENT	KOL MİKTARI/Package 1000 Adet / Piece			
<b>ASI-P 100.1</b>				
ORTA KAYIT BAĞLANTI T JOINT FIXING	KOL MİKTARI/Package 250 Adet / Piece			
<b>ASI-PB 1119</b>				
PML KÖŞE BAĞLANTI CORNER JOINT	KOL MİKTARI/Package Adet / Piece			
<b>ASI-PB 1126</b>				
PML KÖŞE BAĞLANTI CORNER JOINT	KOL MİKTARI/Package Adet / Piece			
<b>ASI-PB 219</b>				
KÖŞE BAĞLANTI CORNER JOINT	KOL MİKTARI/Package Adet / Piece			
<b>ASI-KT 1119</b>				
KÖŞE TAKOZU CORNER JOINT	KOL MİKTARI/Package Adet / Piece			
<b>ASI-KT 1126</b>				
KÖŞE TAKOZU CORNER JOINT	KOL MİKTARI/Package Adet / Piece			
<b>ASI-BZ 5007</b>				
SİNEKLİK KÖŞE TAKOZU FLYSCREEN CORNER JOINT	KOL MİKTARI/Package Adet / Piece			
<b>501 EKO PANÇ</b>				
KÖŞE PML BAĞLANTI PANÇ MAKİNESİ PUNCH MACHINE FOR CORNER JOINT WITH PIN	KOL MİKTARI/Package Adet / Piece			

SL40T - 1,4mm

ISI YALITIMLI SÜRME SİSTEMİ  
THERMAL SLIDING SYSTEM



**PROFİL DETAYLARI**  
*PROFILE DETAILS*



# SL40T - 1,4mm

ISI YALITIMLI SÜRME SİSTEM  
THERMAL SLIDING SYSTEM

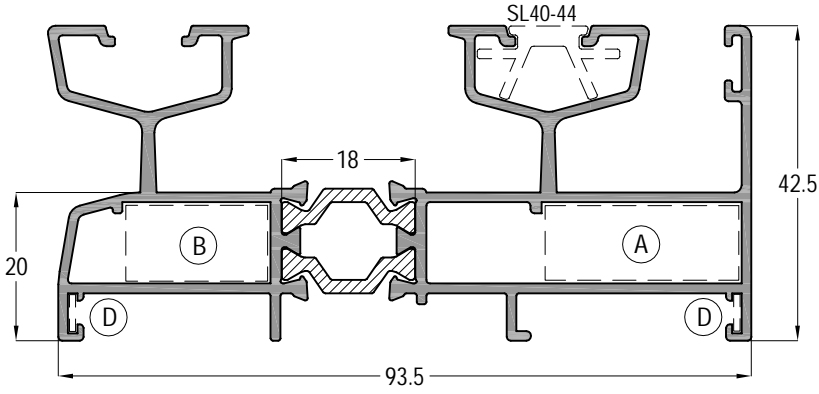

**ASISTAL**



## SL40T 01



			<b>AĞIRLIK / Weight</b>
ASI-KT 1126 ~ ASI-PB 1126	ASI-KT 1119 ~ ASI-PB 1119	ASI-SB 19	1,676 kg/mt

## SL40T 02

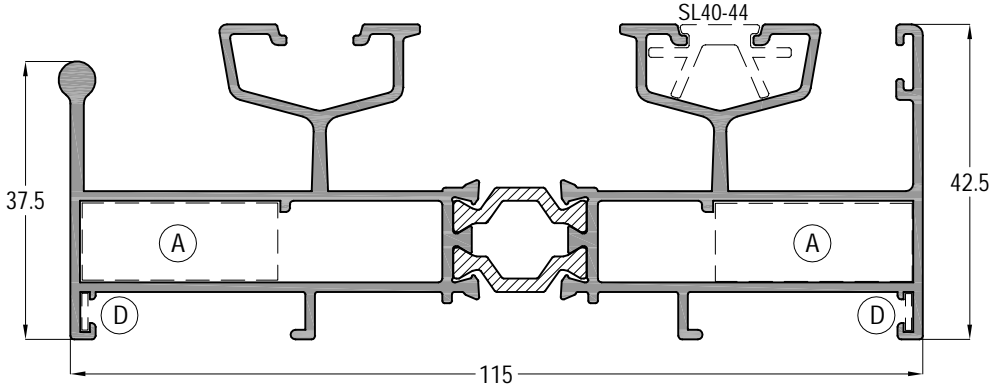
		<b>A İRLİK / Weight</b>
ASI-KT 1126 ~ ASI-PB 1126	ASI-SB 19	1,968 kg/mt



## SL40T 03

			<b>A İRLİK / Weight</b>
ASI-KT 1126 ~ ASI-PB 1126	ASI-KT 1119 ~ ASI-PB 1119	ASI-SB 19	2,569 kg/mt

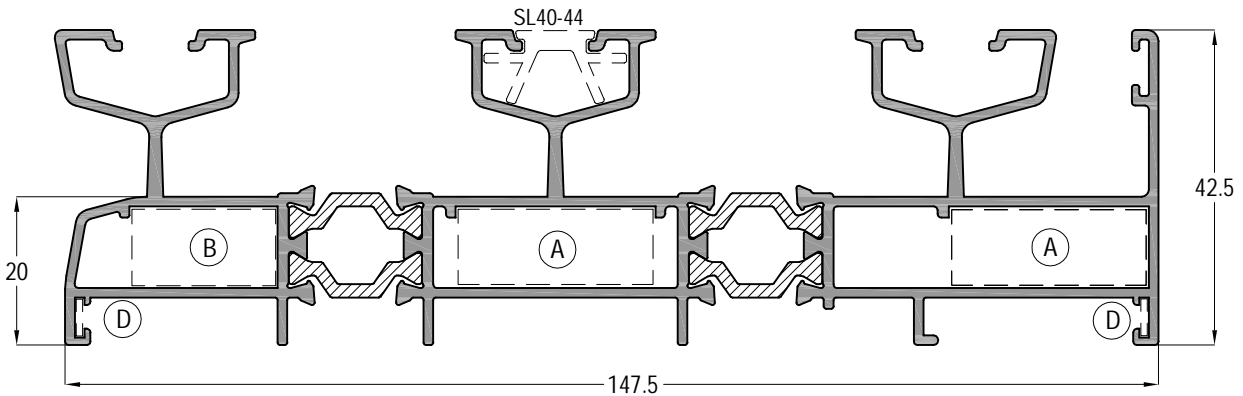

Profil ağırlıklarımız teorik olup; teslim anındaki tartımız geçerlidir.

# SL40T - 1,4mm

ISI YALITIMLI SÜRME SİSTEM  
THERMAL SLIDING SYSTEM

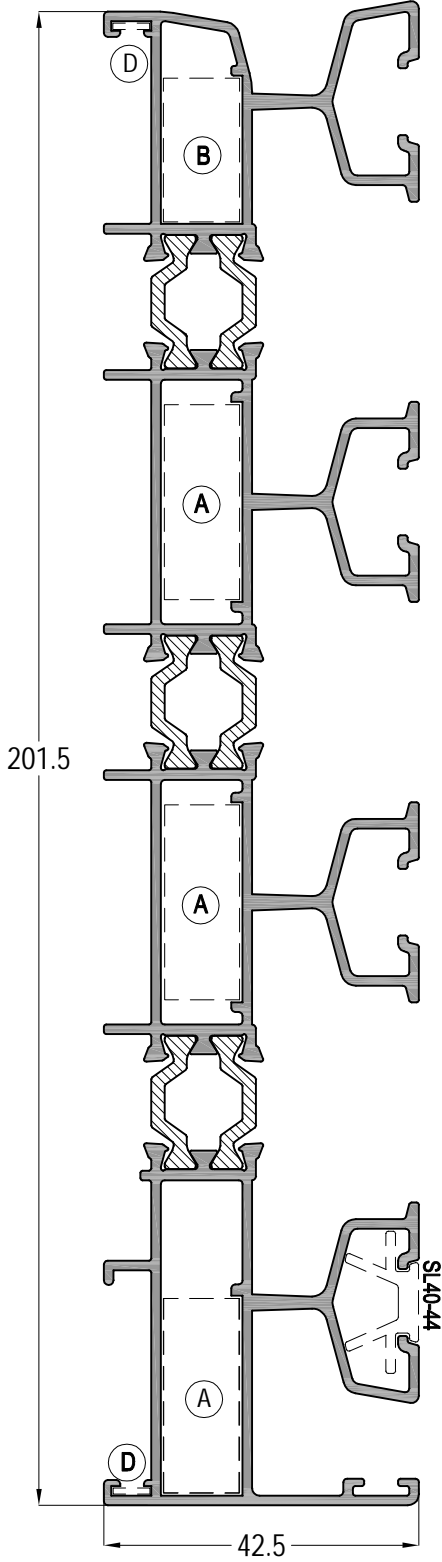

SL40 44 (mat siyah boyalı)	
A	IRLIK / Weight
	0,160 kg/mt

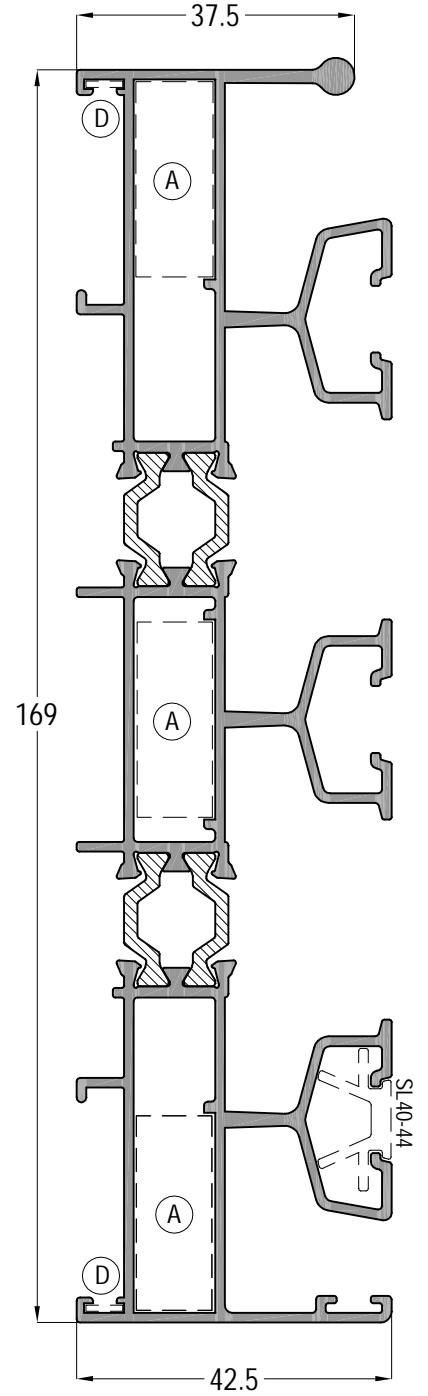

SL40T 06			
			A IRLIK / Weight
ASI-KT 1126 - ASI-PB 1126	ASI-KT 1119 - ASI-PB 1119	ASI-SB 19	3,467 kg/mt

SL40T 05		
		A IRLIK / Weight
ASI-KT 1126 - ASI-PB 1126	ASI-SB 19	2,862 kg/mt

Profil ağırlıklarımız teorik olup; teslim anındaki tartımız geçerlidir.

# SL40T - 1,4mm

ISI YALITIMLI SÜRME SİSTEM  
THERMAL SLIDING SYSTEM

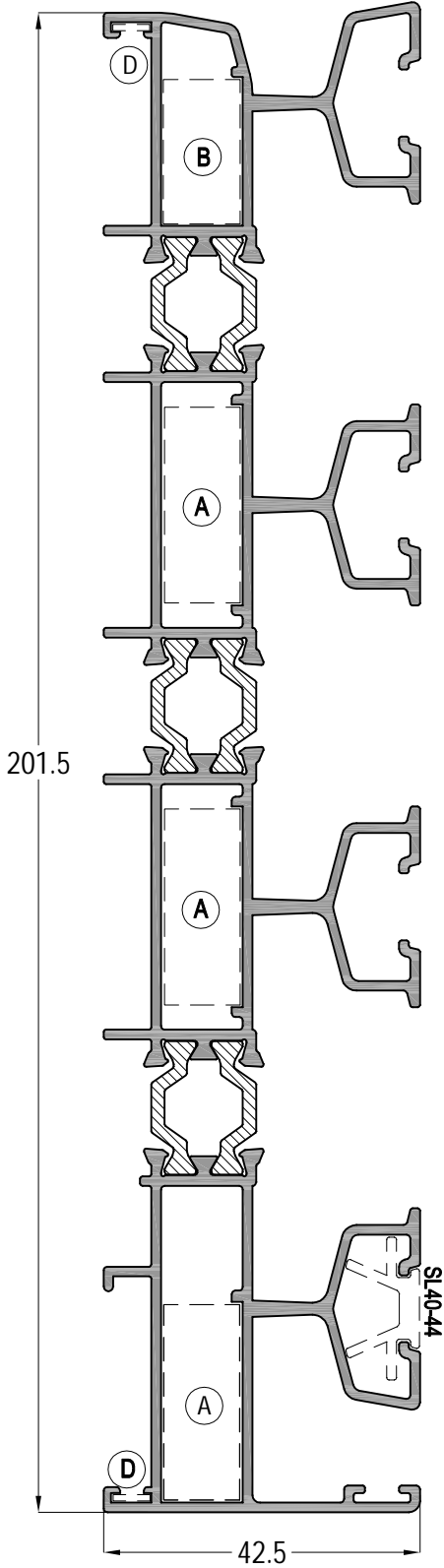

SL40 44 (mat siyah boyalı)

	A IRLIK / Weight
	0,160 kg/mt

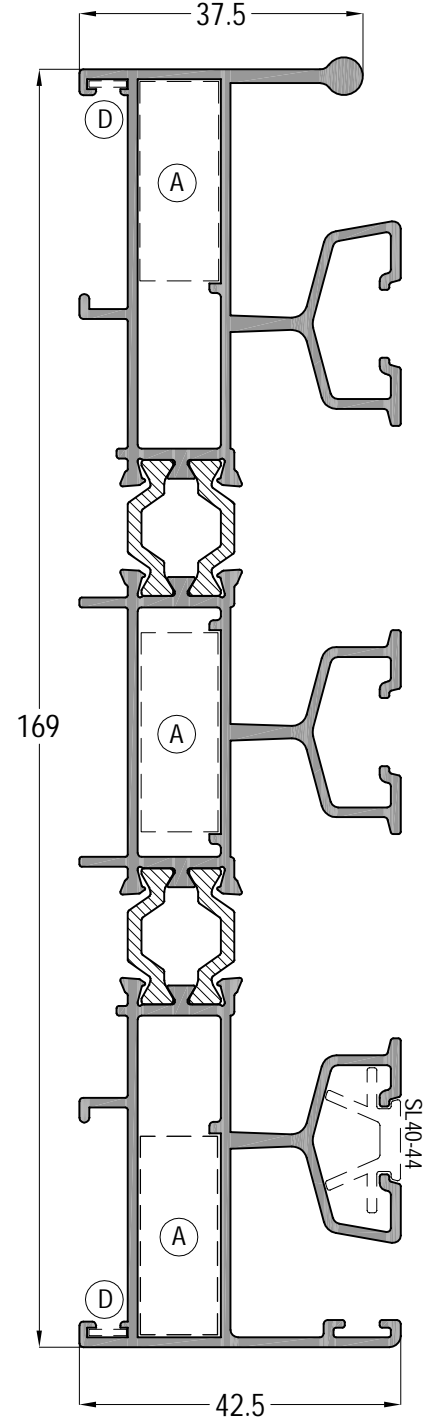

SL40T 06

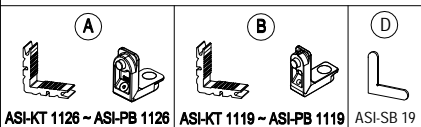

A IRLIK / Weight

3,467 kg/mt

SL40T 05

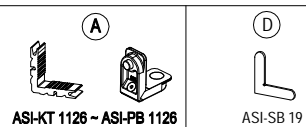

A IRLIK / Weight



2,862 kg/mt

# SL40T - 1,4mm

ISI YALITIMLI SÜRME SİSTEM  
THERMAL SLIDING SYSTEM



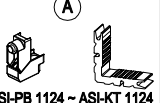

## SL38T 55

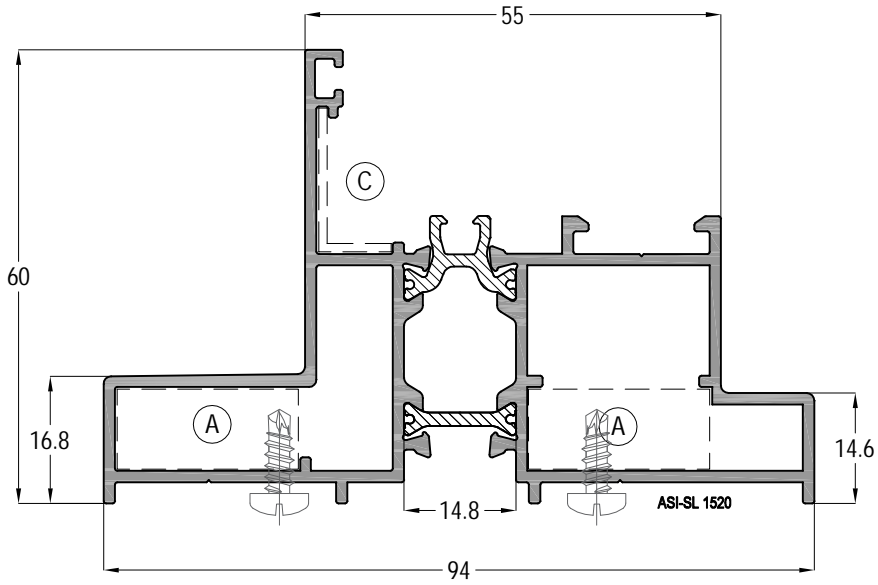
		AĞIRLIK / Weight
		1,613 kg/mt

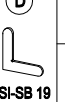

## SL40T 04

			AĞIRLIK / Weight
			1,933 kg/mt

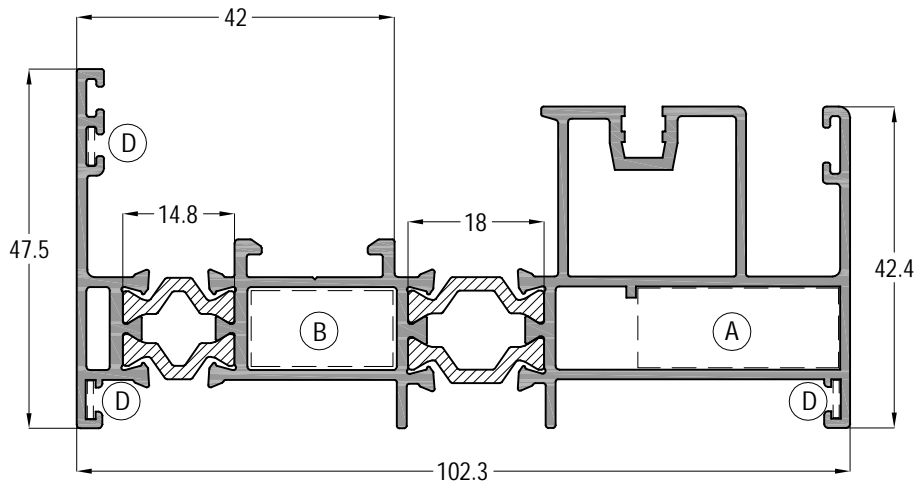



# SL40T - 1,4mm

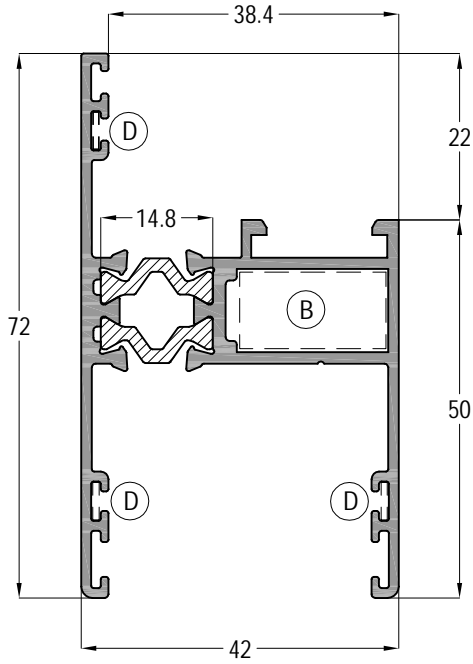

ISI YALITIMLI SÜRME SİSTEM  
THERMAL SLIDING SYSTEM

ASISTAL

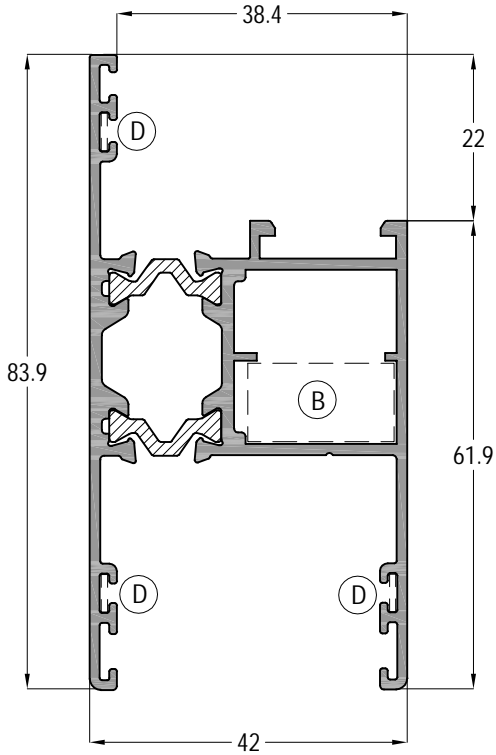

SL40T 11	Jx cm	Jy cm
	10,64	10,35
 (B)	 (D)	A IRLIK / Weight
ASI-KT 1119 ~ ASI-PB 1119	ASI-SB 19	1,092 kg/mt



SL40T 12	Jx cm	Jy cm
	12,43	18,20
 (B)	 (D)	A IRLIK / Weight
ASI-KT 1119 ~ ASI-PB 1119	ASI-SB 19	1,318 kg/mt

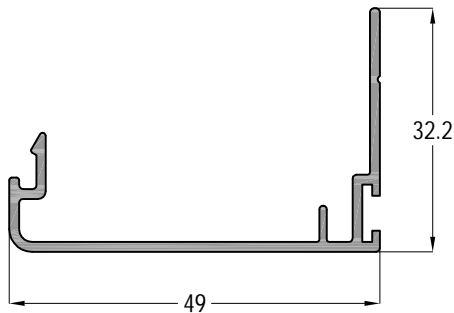



SL40T 41	A IRLIK / Weight
	0,372 kg/mt

# SL40T - 1,4mm

ISI YALITIMLI SÜRME SİSTEM  
THERMAL SLIDING SYSTEM

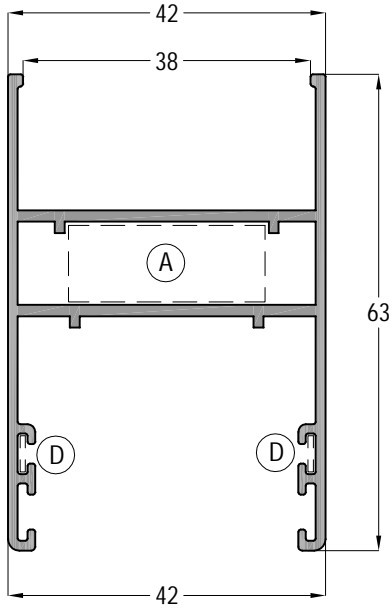
**ASISTAL**



SL40 13	Jx cm	Jy cm
	9,43	8,09
 (A) ASI-KT 1126 - ASI-PB 1126	A İRLİK / Weight	
	0,865 kg/mt	
 (D) ASI-SB 19		

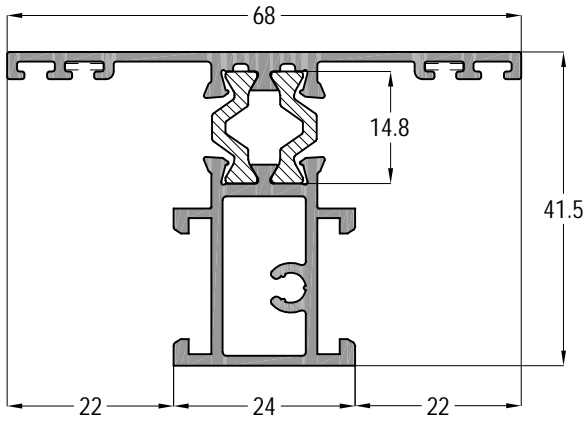

SL40T 21	
	AĞIRLIK / Weight
	1,004 kg/mt

LS60 71	
 MO60-19	AĞIRLIK / Weight
	2,050 kg/mt

LS60 72	
	AĞIRLIK / Weight
	0,420 kg/mt

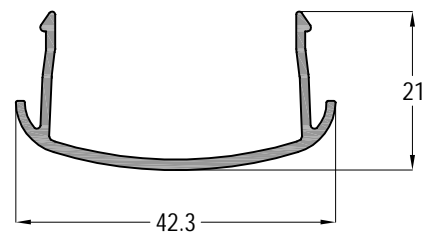
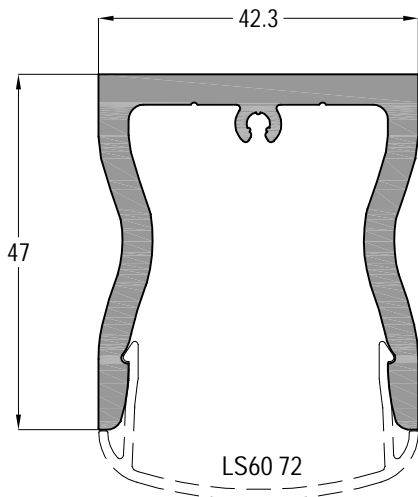

# SL40T - 1,4mm

ISI YALITIMLI SÜRME SİSTEM  
THERMAL SLIDING SYSTEM



## SL40T 42

 SL40-KP02	AĞIRLIK / Weight
	0,738 kg/mt

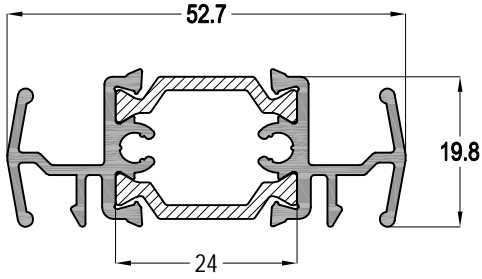

## SL40 81

	AĞIRLIK / Weight
	0,572 kg/mt

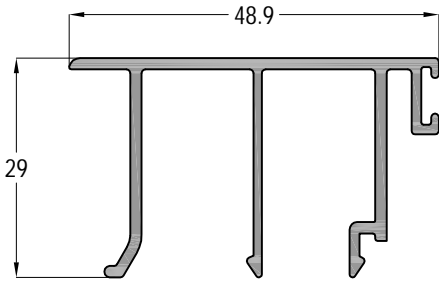

## SL40 82

	AĞIRLIK / Weight
	0,588 kg/mt

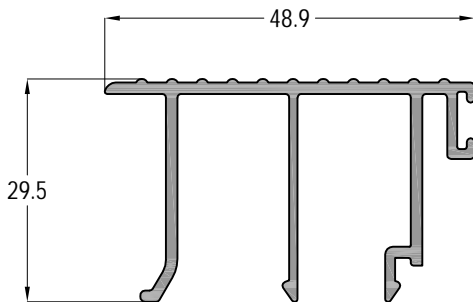

## SL40 72

	AĞIRLIK / Weight
	0,986 kg/mt

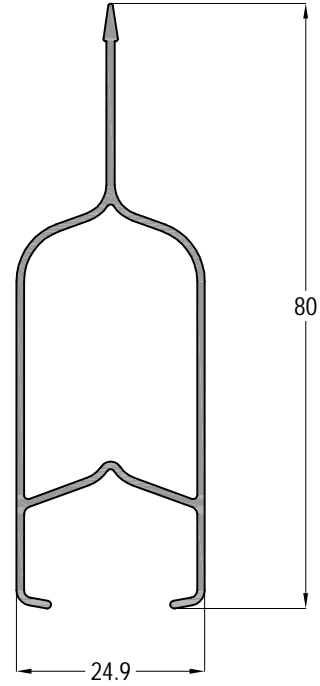

## SL40 73

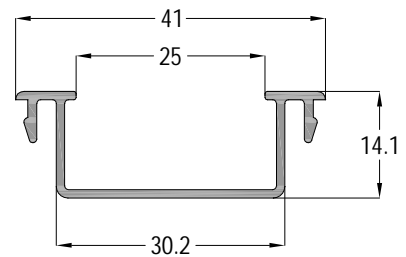

	AĞIRLIK / Weight
	0,245 kg/mt



# SL40T - 1,4mm

ISI YALITIMLI SÜRME SİSTEM  
THERMAL SLIDING SYSTEM



15-304216-09		
 ASI-BZ 5007	 ASI-BZ 5060	A IRLIK / Weight 0,352 kg/mt

15-306317-11		
 ASI-BZ 5007	 ASI-BZ 5060	A IRLIK / Weight 0,561 kg/mt

SL40 64	
	A IRLIK / Weight 0,478 kg/mt

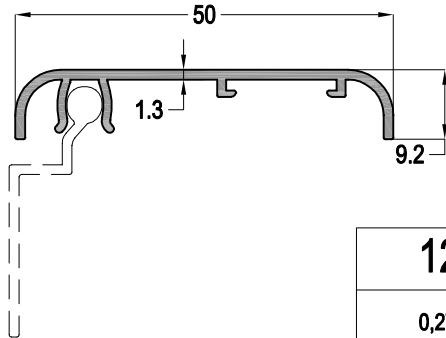
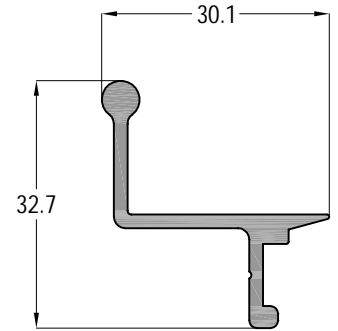
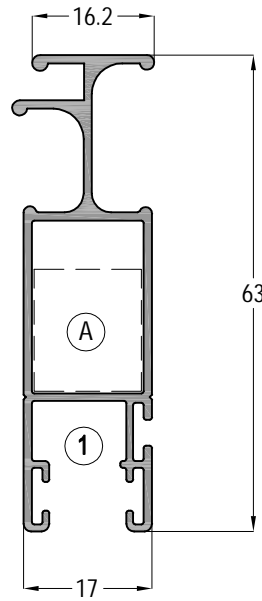
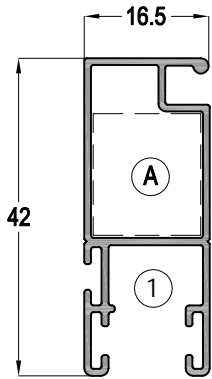

<b>12-52</b>
0,279 kg/mt

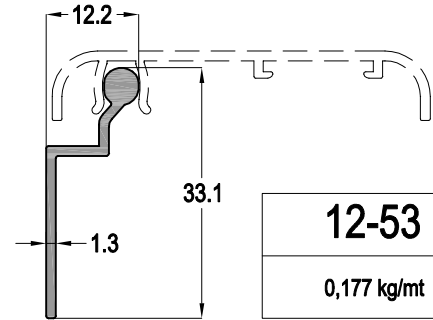

<b>12-53</b>
0,177 kg/mt

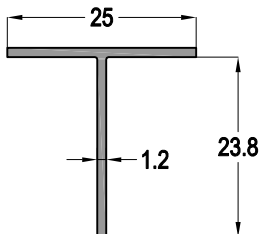

<b>04-025025-12</b>
0,158 kg/mt

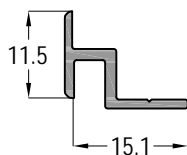

<b>SL40 45</b>
0,114 kg/mt

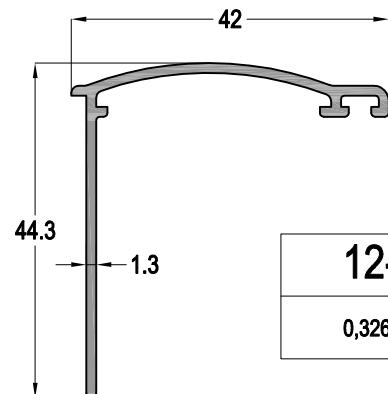

<b>12-54</b>
0,326 kg/mt



# SL40T - 1,4mm

ISI YALITIMLI SÜRME SİSTEM  
THERMAL SLIDING SYSTEM



SL40 61	
A IRLIK / Weight	
	0,148 kg/mt

SL40 62	
A IRLIK / Weight	
	0,134 kg/mt

SL40 63	
A IRLIK / Weight	
	0,140 kg/mt

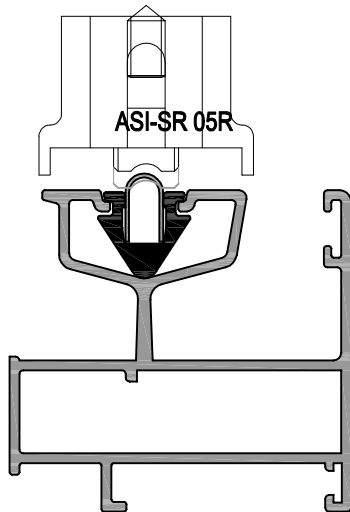
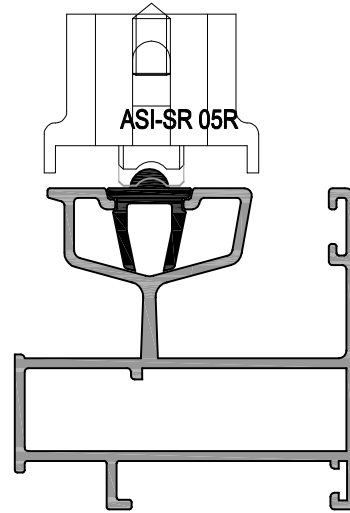
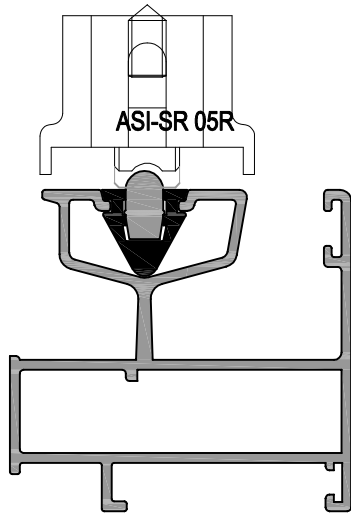
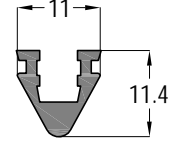
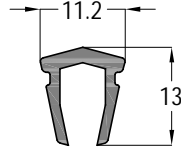
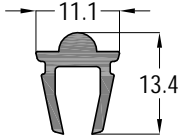

### SL40T 11 ve SL40T 12 KANATLARI İÇİN SASH FOR SL40T 11 & SL40T 12

CAM KALINLI INA GÖRE CAM ÇİTASI SEÇ M TABLOSU  
Glazing Bead Selection Table according to the Glass  
Thickness

CAM KALINLI I Glass Thickness (mm)	CAM ÇİTASI Glazing Bead	Ç CAM F T L Glass Gasket (IN)	DI CAM F T L Glass Gasket (OUT)
4	11-026	EP2-03	EP1-01
5	11-026	EP2-02	EP1-01
6	11-026	EP2-01	EP1-01
8	11-022	EP2-03	EP1-01
9	11-022	EP2-02	EP1-01
10	11-022	EP2-01	EP1-01
11	11-020	EP2-02	EP1-01
12	11-020	EP2-01	EP1-01
13	11-017	EP2-03	EP1-01
14	11-017	EP2-02	EP1-01
15	11-017	EP2-01	EP1-01
16	11-015	EP2-02	EP1-01
17	11-015	EP2-01	EP1-01
20	11-010	EP2-03	EP1-01
21	11-010	EP2-02	EP1-01
22	11-010	EP2-01	EP1-01
24	11-006	EP2-03	EP1-01
25	11-006	EP2-02	EP1-01
26	11-006	EP2-01	EP1-01
27	11-004	EP2-02	EP1-01
28	11-004	EP2-01	EP1-01

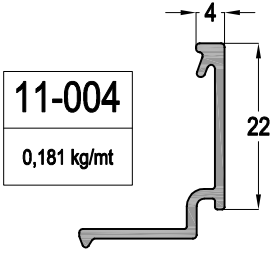

11-006  
0,218 kg/mt

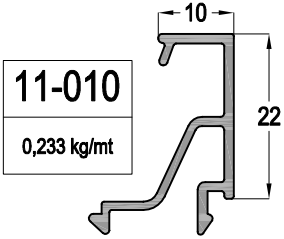
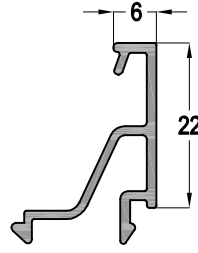

11-015  
0,241 kg/mt

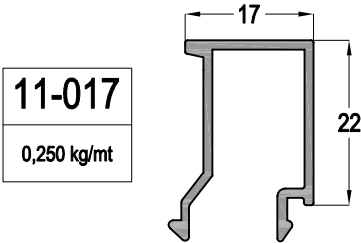
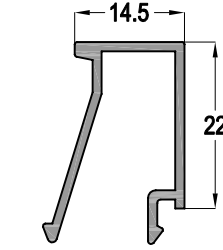

11-020  
0,276 kg/mt

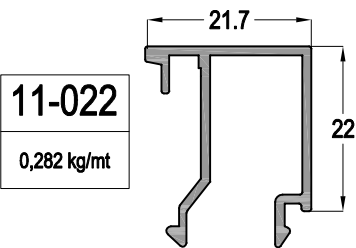
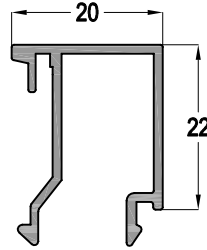

11-026  
0,296 kg/mt

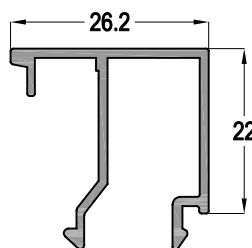



## AÇILIM TİPLERİ - OPENING TYPES

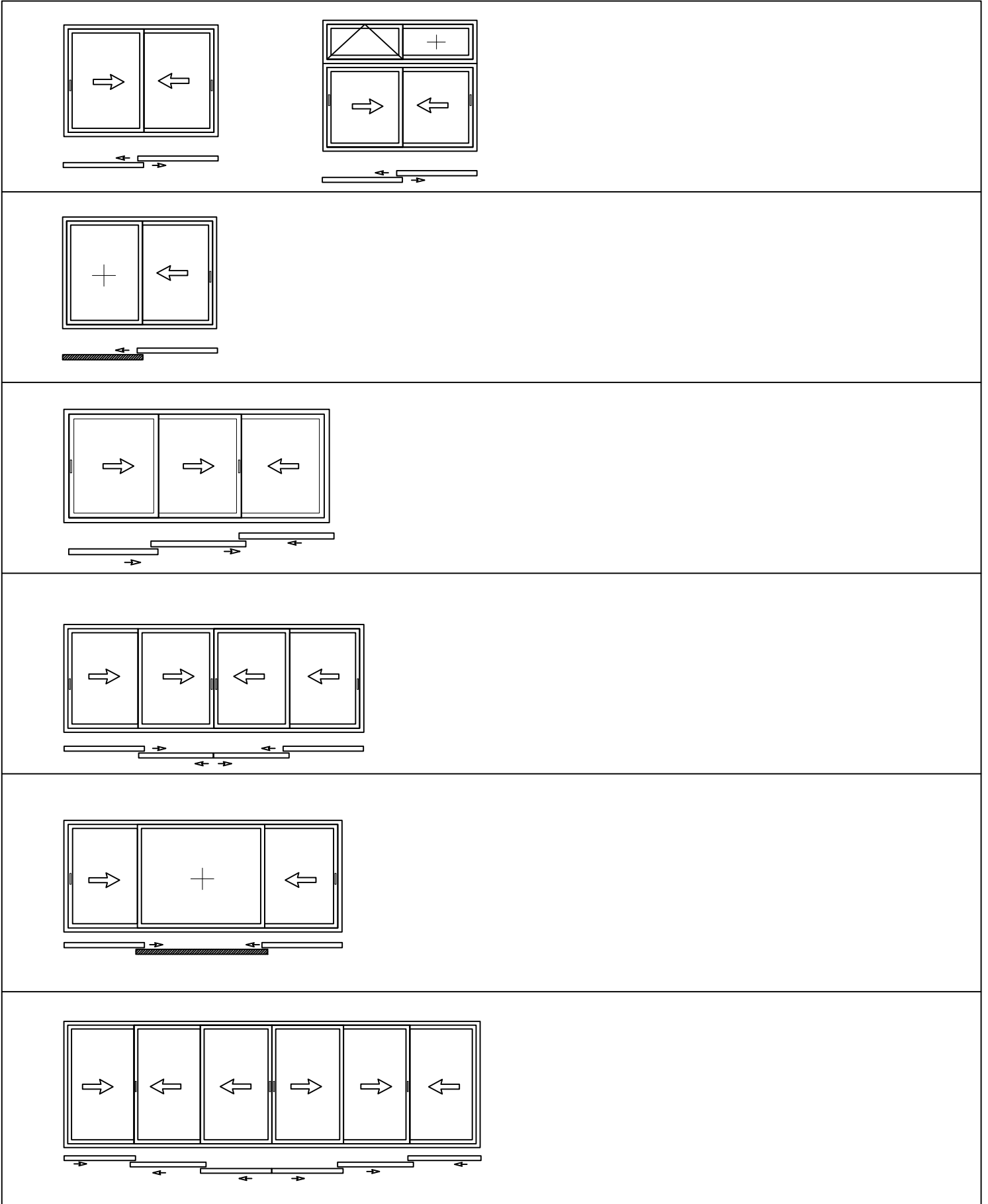

### RÜZGAR YÜKÜNE GÖRE MAKSİMUM KANAT EBATLARI MAXIMUM SASH DIMENSIONS FOR GIVEN WIND PRESSURE

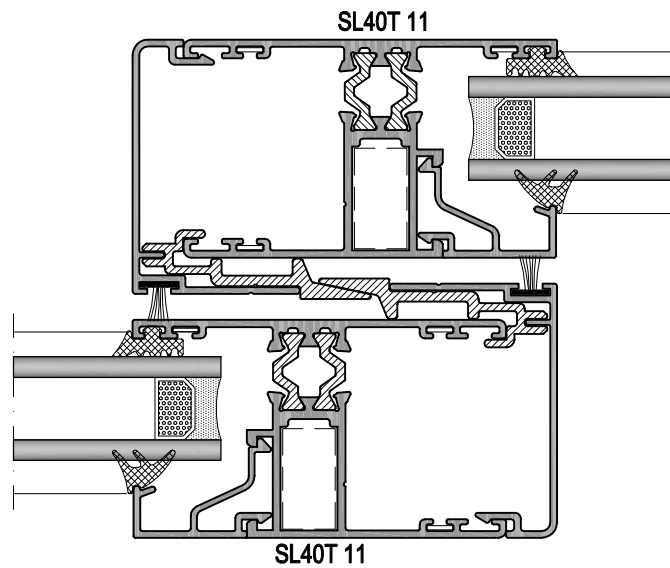
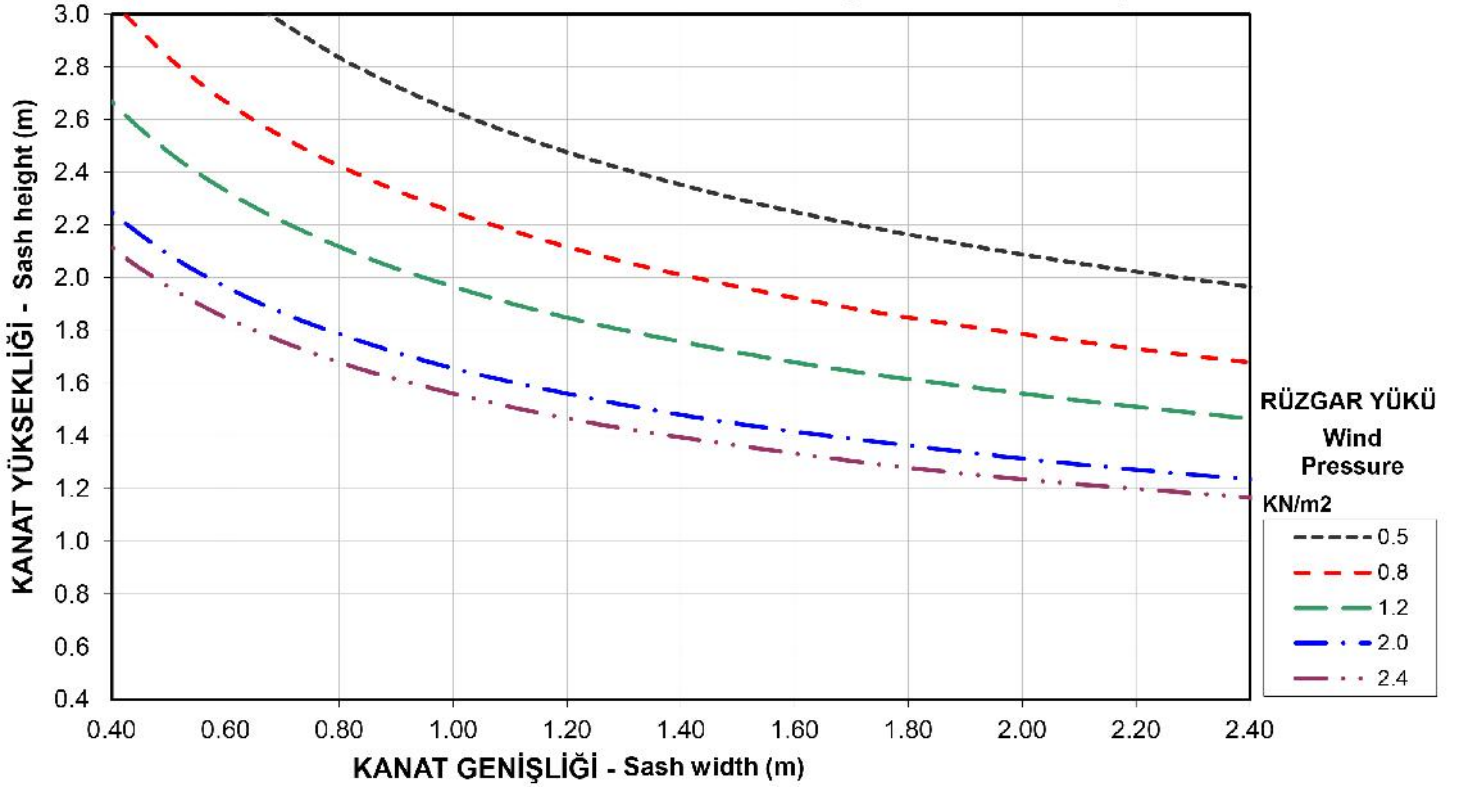

KANAT EBATLARI BELİRLENİRKEN RULMANIN TAŞIMA KAPASİTESİNİ GEÇMEMESİNE DİKKAT EDİLMELİDİR  
WHILE THE DETERMINE SASH DIMENSIONS, SASH WEIGHT MUST BE LESS THAN ROLLER CARY CAPACITY

### RÜZGAR YÜKÜNE GÖRE MAKSİMUM KANAT EBATLARI MAXIMUM SASH DIMENSIONS FOR GIVEN WIND PRESSURE

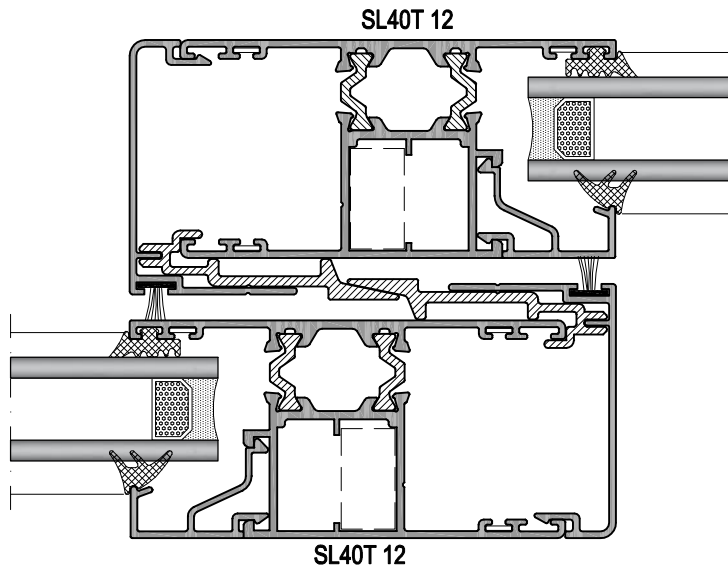
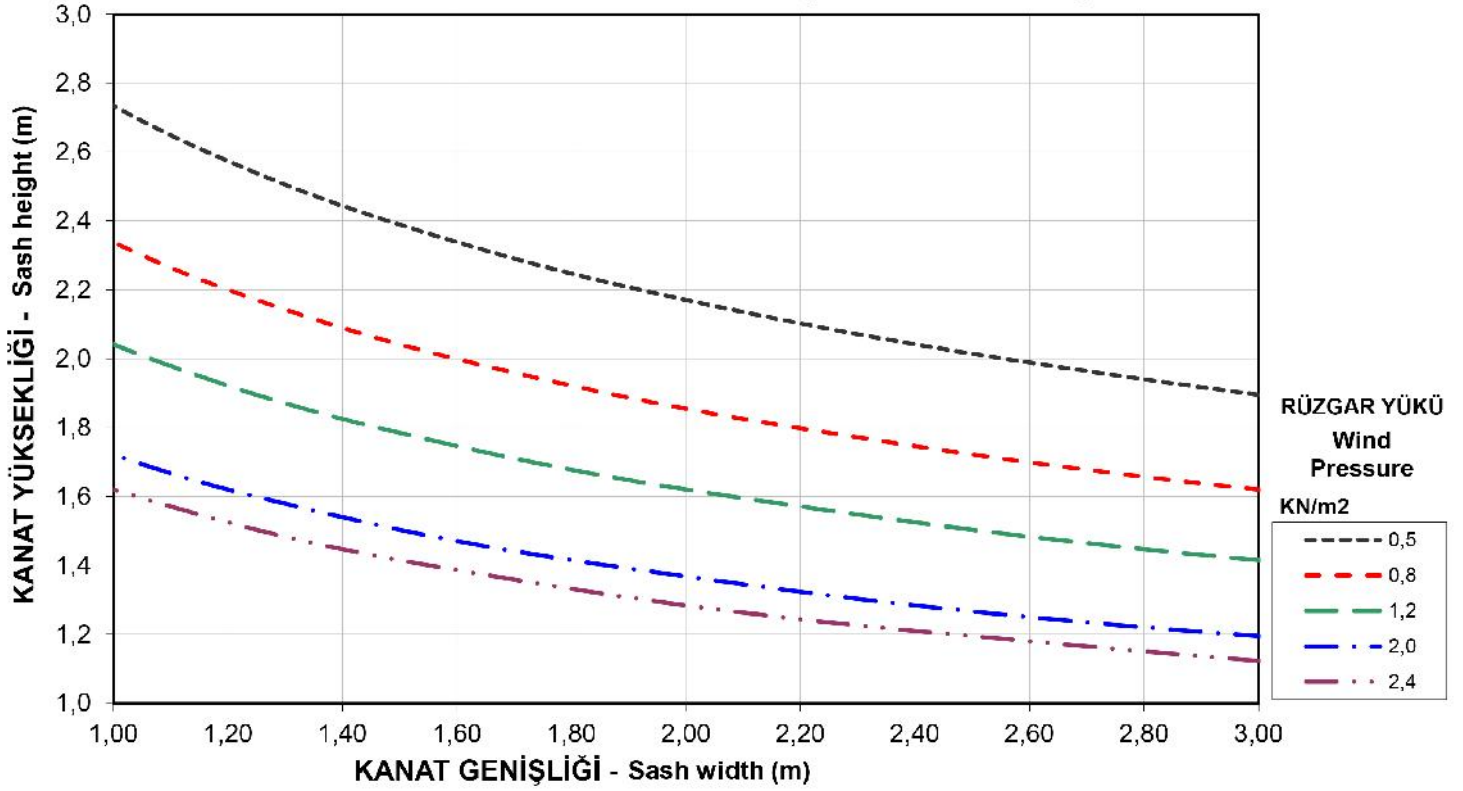

KANAT EBATLARI BELİRLENİRKEN RULMANIN TAŞIMA KAPASİTESİNİ GEÇMEMESİNE DİKKAT EDİLMELİDİR  
WHILE THE DETERMINE SASH DIMENSIONS, SASH WEIGHT MUST BE LESS THAN ROLLER CARY CAPACITY

### RÜZGAR YÜKÜNE GÖRE MAKSİMUM KANAT EBATLARI MAXIMUM SASH DIMENSIONS FOR GIVEN WIND PRESSURE

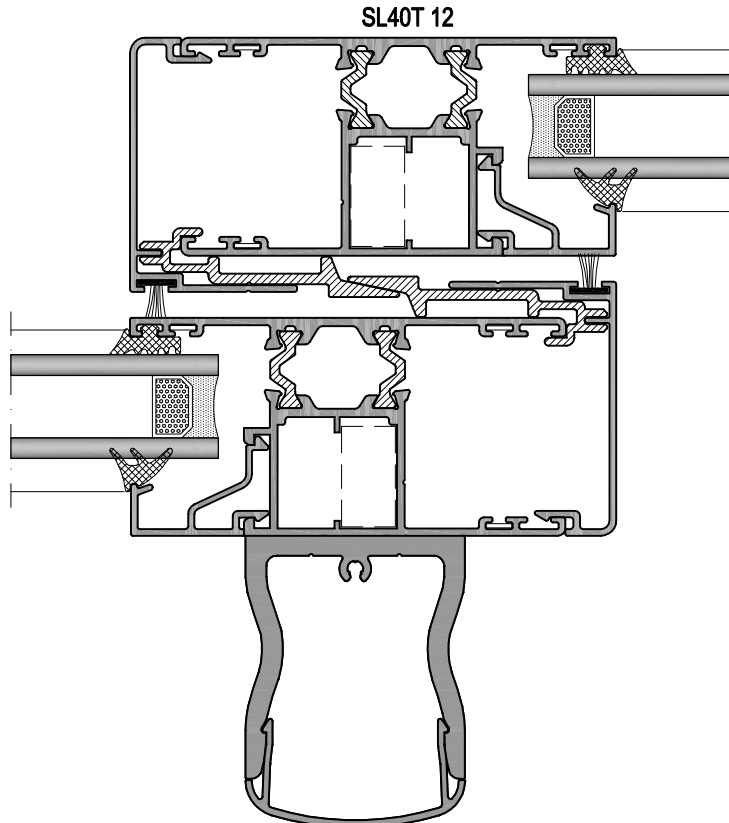
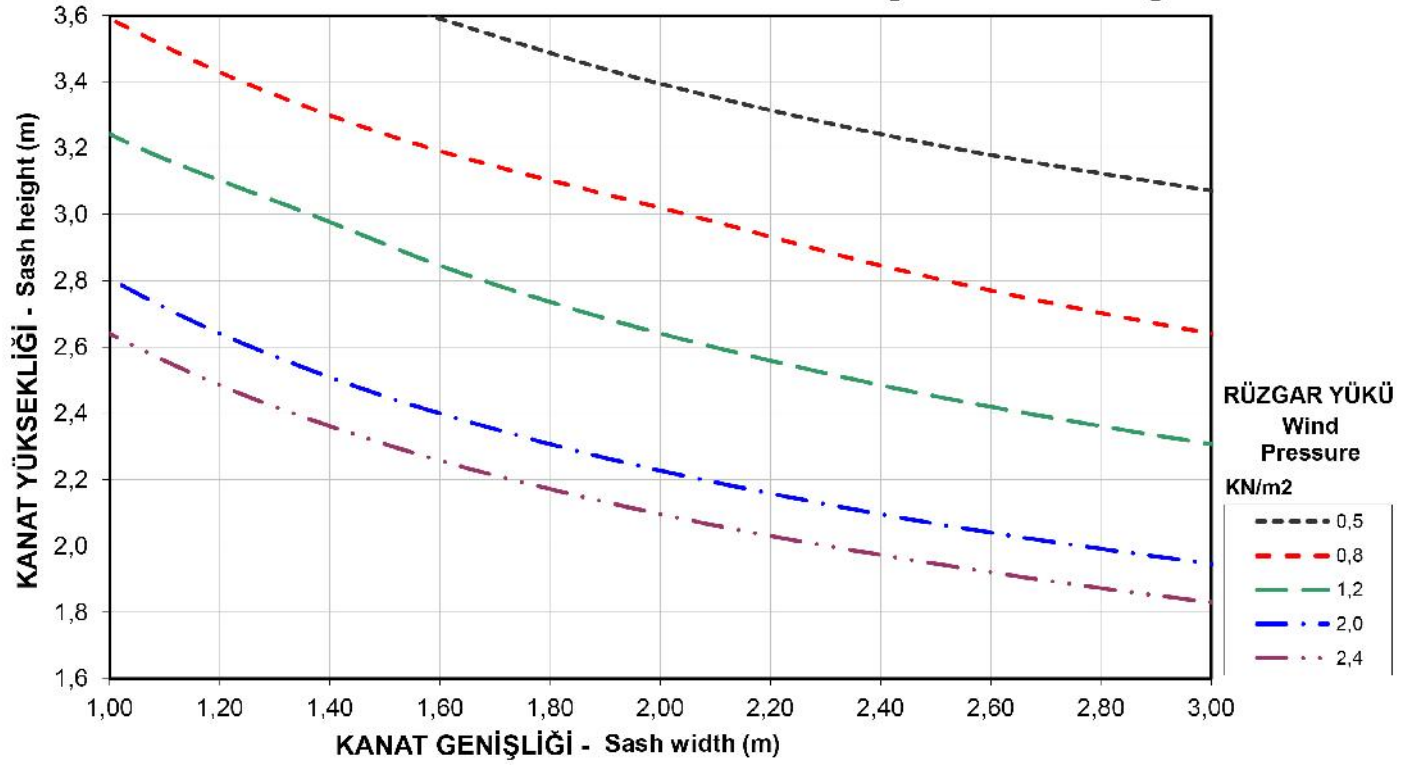

KANAT EBATLARI BELİRLENİRKEN RULMANIN TAŞIMA KAPASİTESİNİ GEÇMEMESİNE DİKKAT EDİLMELİDİR  
WHILE THE DETERMINE SASH DIMENSIONS, SASH WEIGHT MUST BE LESS THAN ROLLER CARY CAPACITY

SL40T - 1,4mm

ISI YALITIMLI SÜRME SİSTEMİ  
THERMAL SLIDING SYSTEM



## SİSTEM DETAYLARI *SYSTEM DETAILS*

# SL40T - 1,4mm

YALITIMLI SÜRME SİSTEMİ  
THERMAL SLIDING SYSTEM

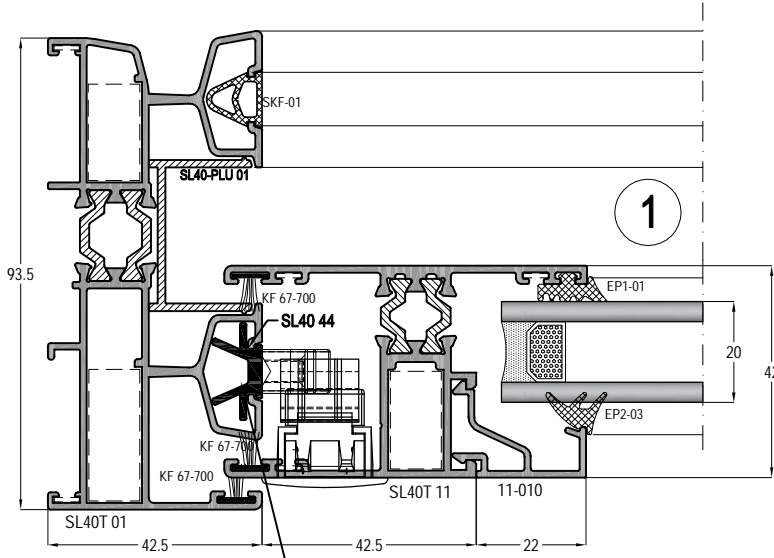

K L T KAR ILI I KULLANILACAK TARAF  
MÜTLAKA SL40 44 PROF L TAKILMALIDIR  
You have to use SL40 44 profile  
in the frame for locking part

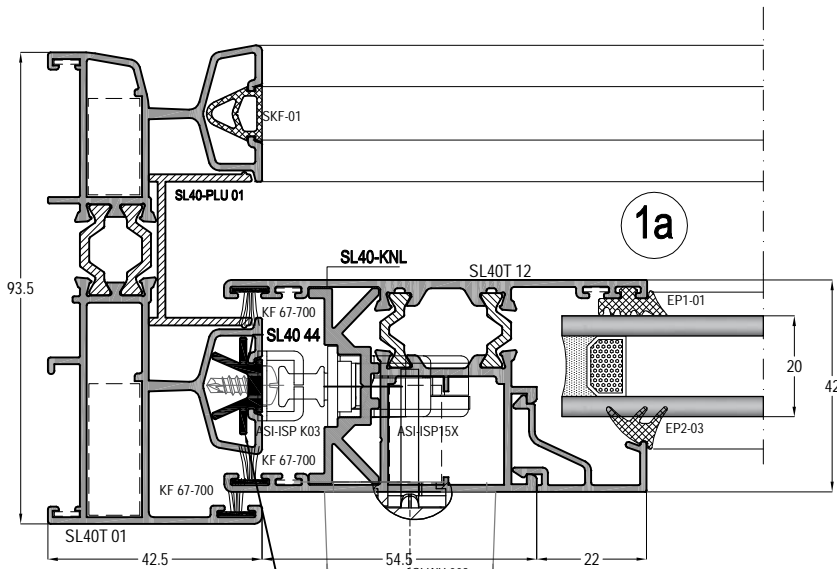
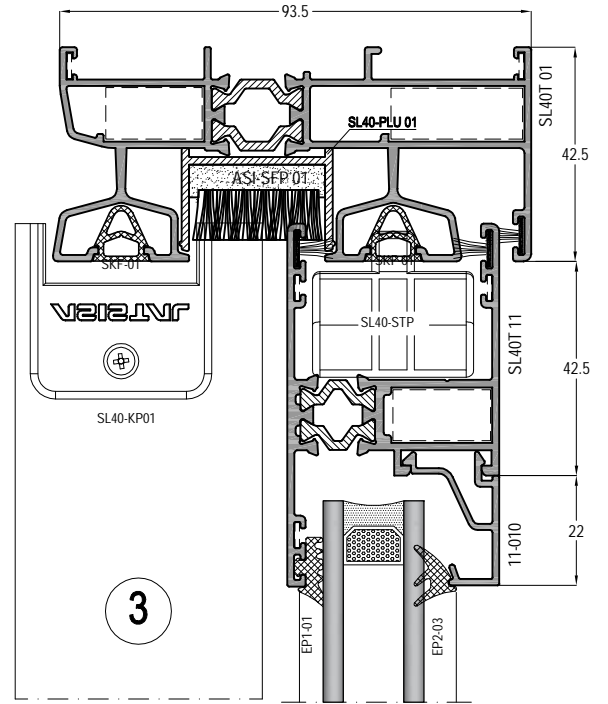
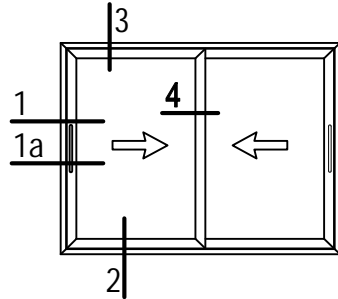

K L T KAR ILI I KULLANILACAK TARAF  
MÜTLAKA SL40 44 PROF L TAKILMALIDIR  
You have to use SL40 44 profile  
in the frame for locking part

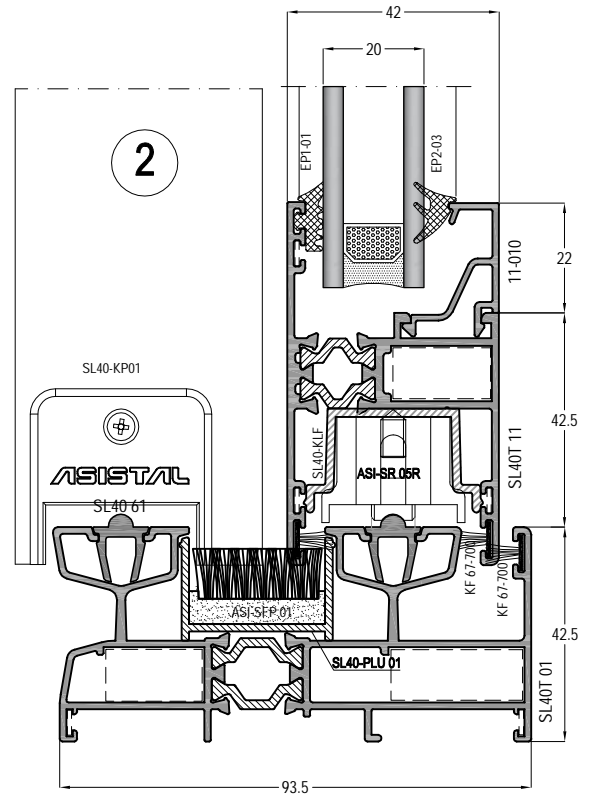



# SL40T - 1,4mm

YALITIMLI SÜRME SİSTEM  
THERMAL SLIDING SYSTEM

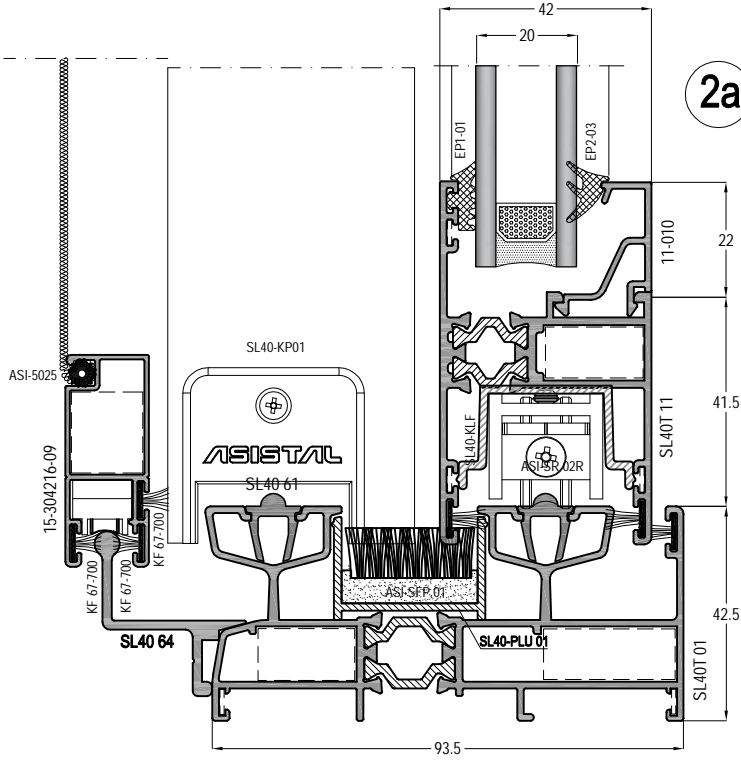

2a

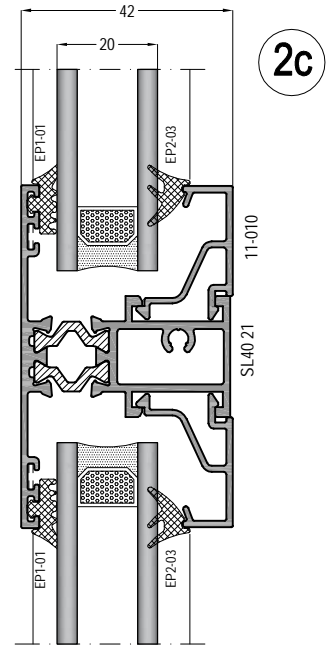

2c

2b

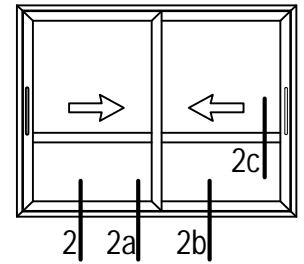
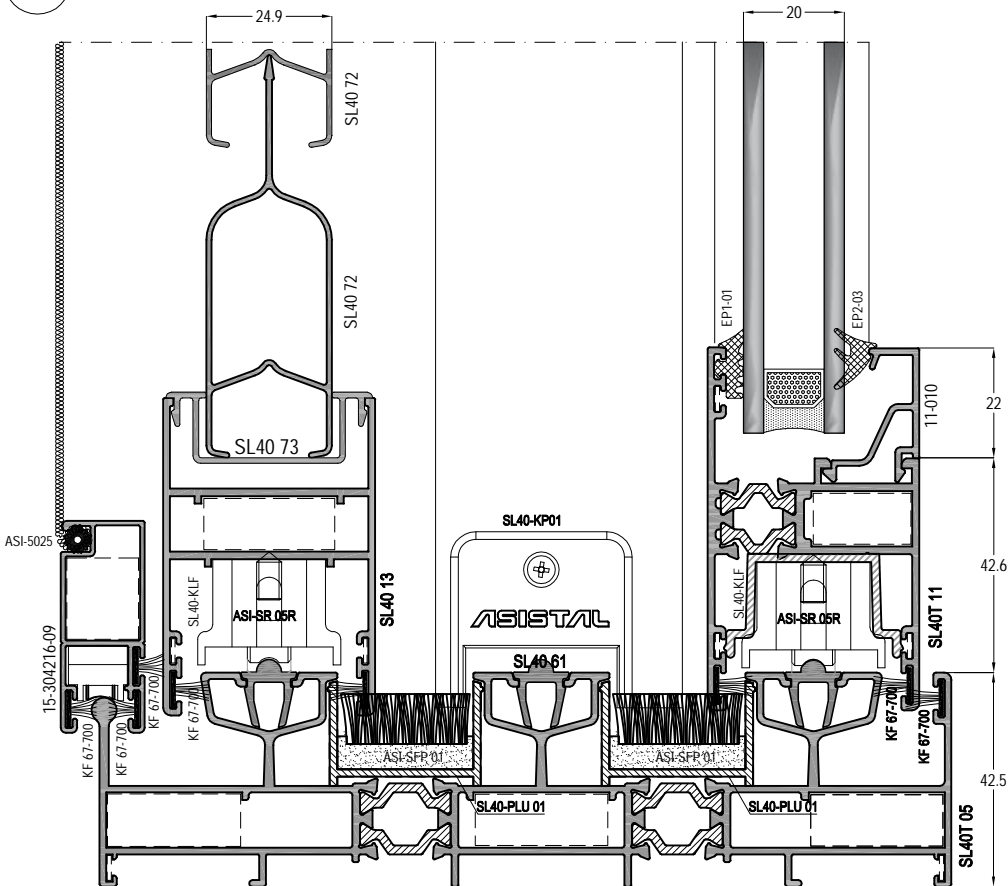

# SL40T - 1,4mm

YALITIMLI SÜRME SİSTEM  
THERMAL SLIDING SYSTEM



4

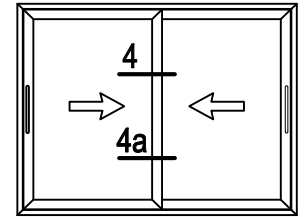
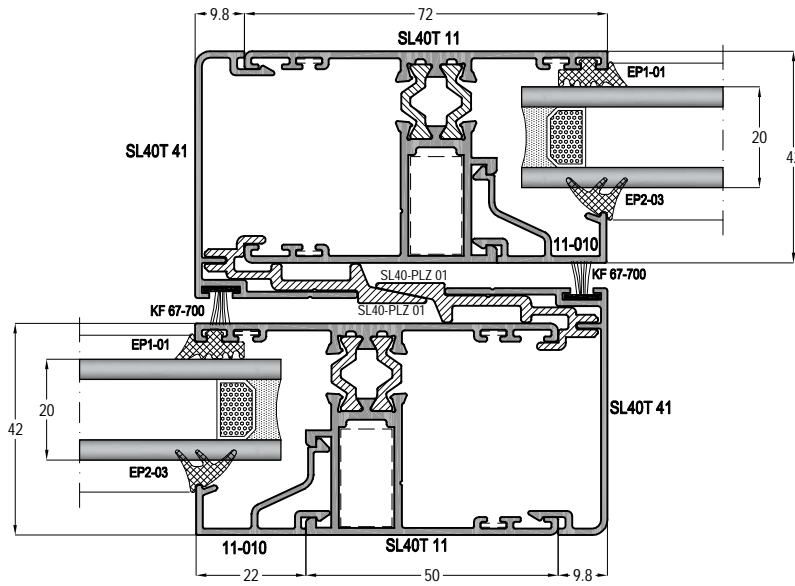

4a

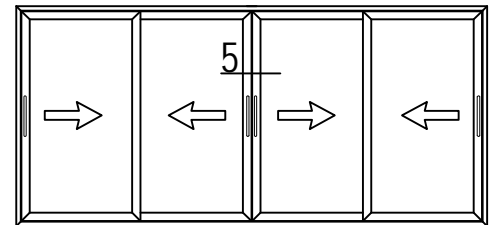
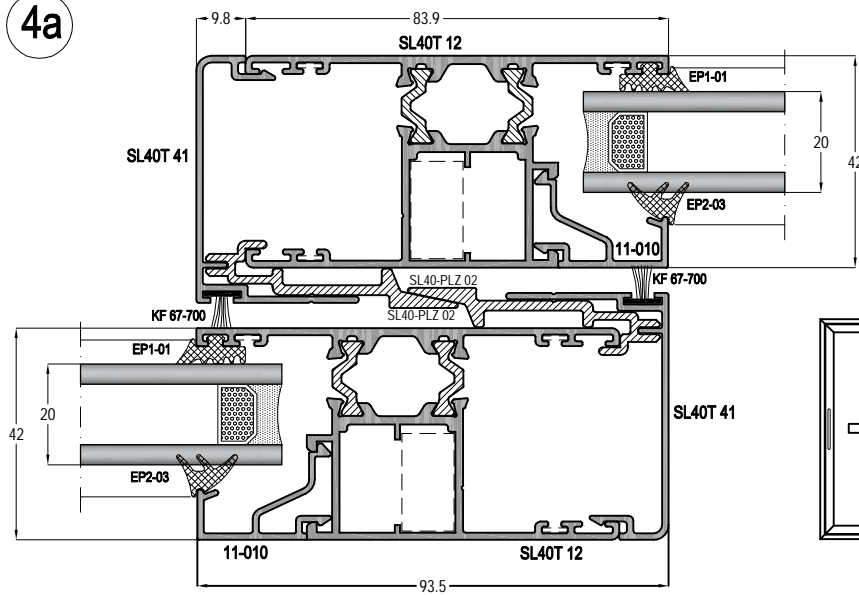

5

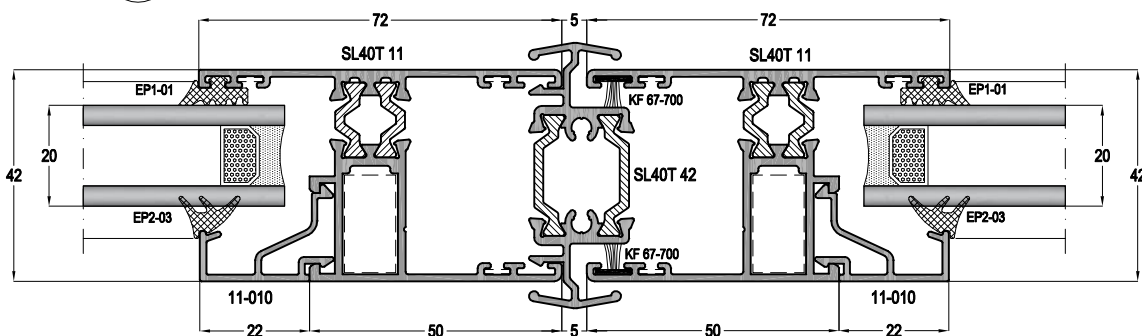

# SL40T - 1,4mm

YALITIMLI SÜRME SİSTEM  
THERMAL SLIDING SYSTEM

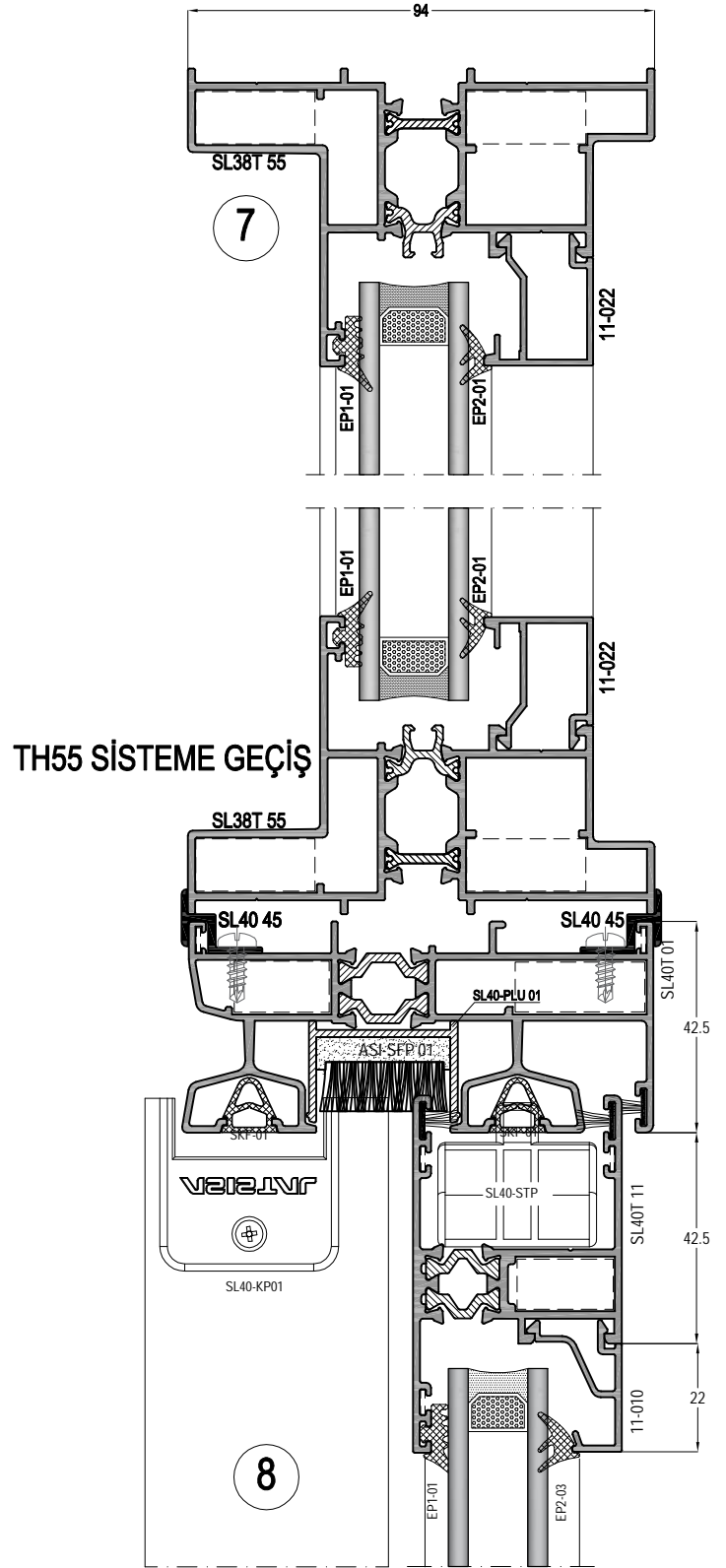
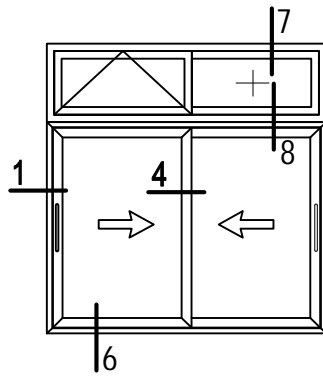
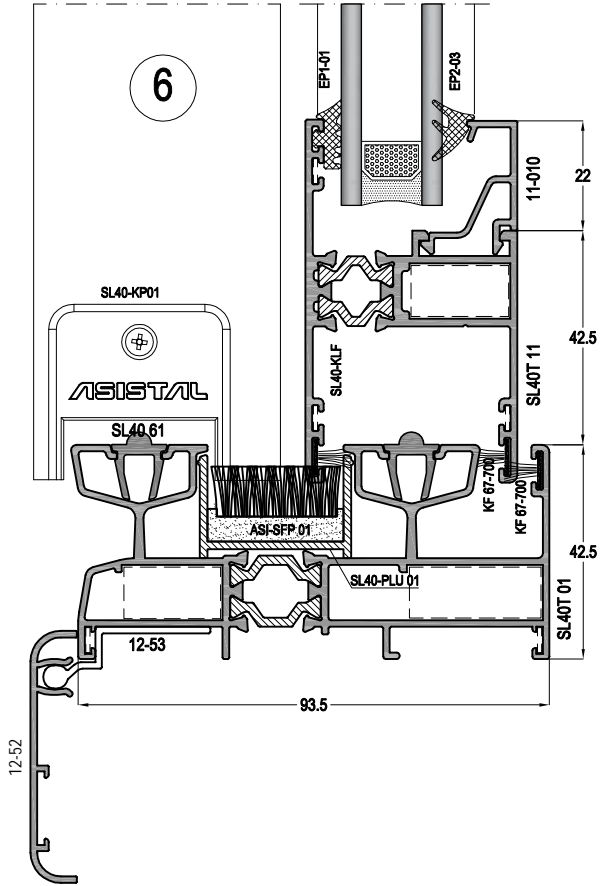

# SL40T - 1,4mm

YALITIMLI SÜRME SİSTEMİ  
THERMAL SLIDING SYSTEM



9

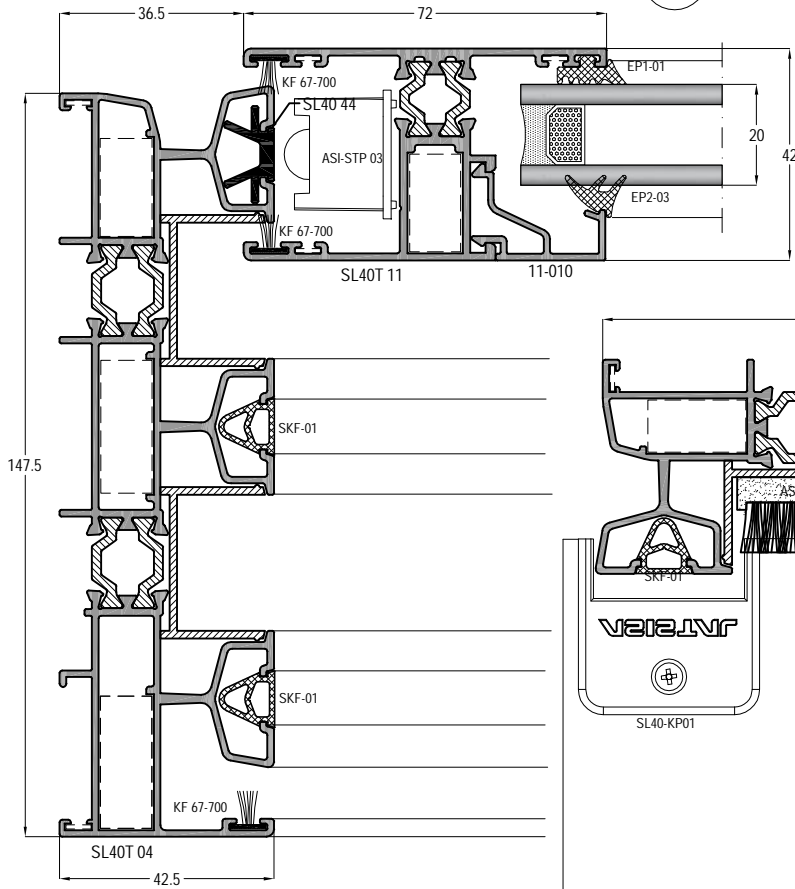

10

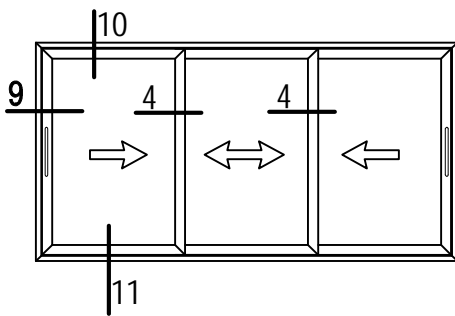
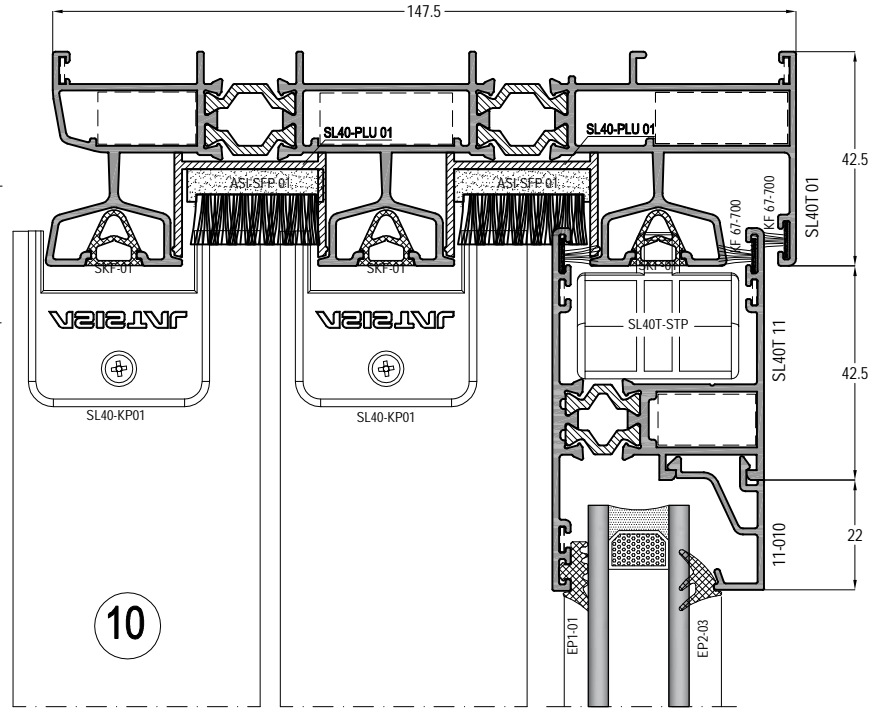

11

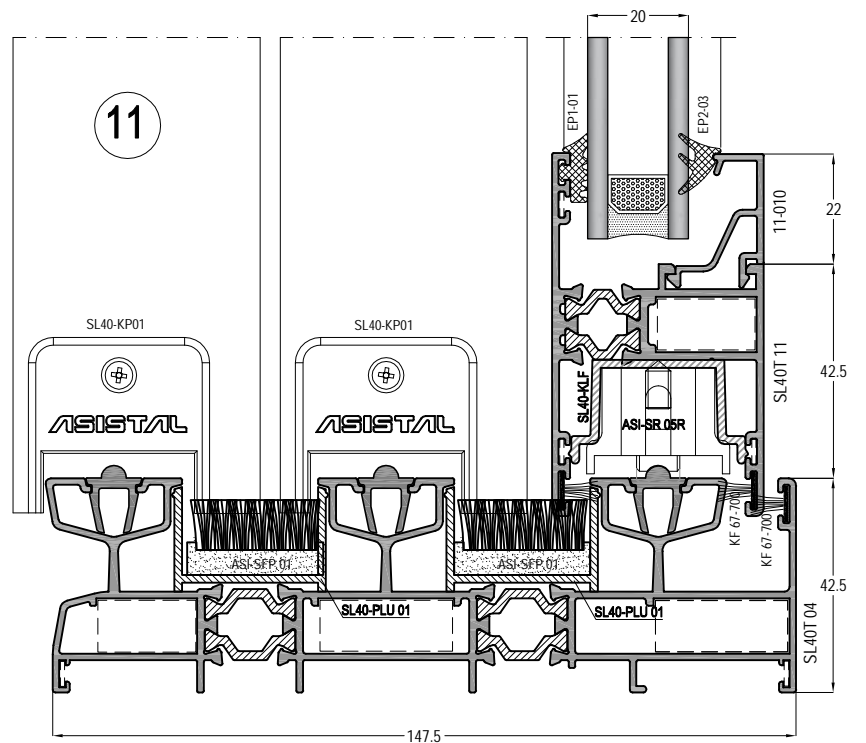

# SL40T - 1,4mm

YALITIMLI SÜRME SİSTEMİ  
THERMAL SLIDING SYSTEM

