

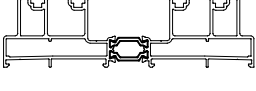

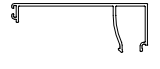

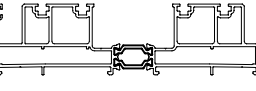





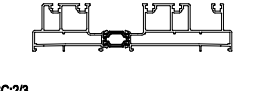

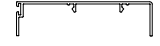
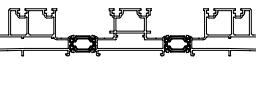
**LS70 - 1,8mm**

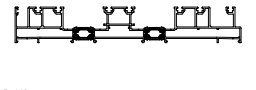
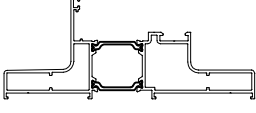
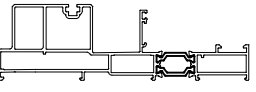
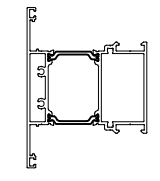
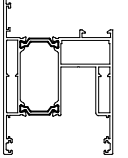

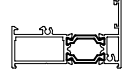

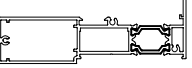









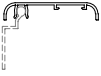



YALITIMLI KALDIR-SÜR SİSTEMİ  
THERMAL LIFT&SLIDE SYSTEM

**ASISTAL**

**PROFİL VE AKSESUAR LİSTELERİ**  
*PROFILE & ACCESSORIES LIST*

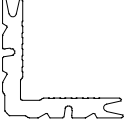
<b>LS70 01</b>			<b>LS70 40</b>		
<b>KASA PROFİLİ</b> FRAME PROFILE	<b>AĞIRLIK / Weight</b> 3,326 kg/mt		<b>KAPAK PROFİLİ</b> COVER PROFILE	<b>AĞIRLIK / Weight</b> 0,694 kg/mt	
<b>LS70 02</b>			<b>LS70 41</b>		
<b>KASA PROFİLİ</b> FRAME PROFILE	<b>AĞIRLIK / Weight</b> 3,534 kg/mt		<b>KENET PROFİLİ</b> CENTRAL LOCKING PROFILE	<b>AĞIRLIK / Weight</b> 0,441 kg/mt	
<b>LS70 03</b>		 SC:2/3	<b>LS70 42</b>		
<b>İKİLİ KASA PROFİLİ</b> SİNEKLİK RAYLI FRAME PROFILE	<b>AĞIRLIK / Weight</b> 3,847 kg/mt		<b>ADAPTÖR PROFİLİ</b> ADAPTER PROFILE	<b>AĞIRLIK / Weight</b> 1,002 kg/mt	
<b>LS70 04</b>		 SC:2/3	<b>LS70 43</b>		
<b>İKİLİ KASA PROFİLİ</b> SİNEKLİK RAYLI FRAME PROFILE-FLY SCREEN	<b>AĞIRLIK / Weight</b> 4,054 kg/mt		<b>KAPAK PROFİLİ</b> COVER PROFILE	<b>AĞIRLIK / Weight</b> 0,568 kg/mt	
<b>LS70 05</b>		 SC:2/3	<b>LS70 44</b>		
<b>KASA PROFİLİ</b> FRAME PROFILE	<b>AĞIRLIK / Weight</b> 5,181 kg/mt		<b>KENET PROFİLİ</b> CENTRAL LOCKING PROFILE	<b>AĞIRLIK / Weight</b> 0,531 kg/mt	
<b>LS70 06</b>		 SC:1/2	<b>LS70 78</b>		
<b>ÜÇLÜ KASA PROFİLİ</b> SİNEKLİK RAYLI FRAME PROFILE-FLY SCREEN	<b>AĞIRLIK / Weight</b> 5,703 kg/mt		<b>SÜRME SABİT GEÇİŞ</b> PROFİLİ FRAME PROFILE	<b>AĞIRLIK / Weight</b> 2,467 kg/mt	
<b>LS70 08</b>			<b>TH70 23</b>		
<b>KASA PROFİLİ</b> FRAME PROFILE	<b>AĞIRLIK / Weight</b> 2,735 kg/mt		<b>ORTA KAYIT PROFİLİ</b> TRANSOM-MULLION PROFILE	<b>AĞIRLIK / Weight</b> 2,203 kg/mt	
<b>LS70 11</b>			<b>LS60 35</b>		
<b>KANAT PROFİLİ</b> SASH PROFILE	<b>AĞIRLIK / Weight</b> 2,344 kg/mt		<b>KANAT SABİTLEME</b> PROFİLİ SASH FIXING PROFILE	<b>AĞIRLIK / Weight</b> 0,672 kg/mt	
<b>LS70 12</b>			<b>LS70 61</b>		
<b>DAR KANAT PROFİLİ</b> NARROW SASH PROFILE	<b>AĞIRLIK / Weight</b> 1,282 kg/mt		<b>DAMLALIK PROFİLİ</b> COVER PROFILE	<b>AĞIRLIK / Weight</b> 0,231 kg/mt	
<b>LS70 13</b>			<b>13-09986</b>		
<b>DAR KANAT PROFİLİ</b> NARROW SASH PROFILE	<b>AĞIRLIK / Weight</b> 1,961 kg/mt		<b>SİNEKLİK</b> KANAT PROFİLİ FLYSCREEN SASH PROFILE	<b>AĞIRLIK / Weight</b> 0,741 kg/mt	

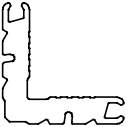
## PROFİL LİSTESİ - PROFILES LIST

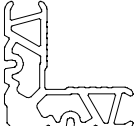
SL32 43			11-022		
PERVAZ MONTAJ PROFİLİ BORDER FIXING PROFILE	AĞIRLIK / Weight 0,235 kg/mt		CAM ÇİTASI-22 mm GLAZING BEAD PROFILE	AĞIRLIK / Weight 0,282 kg/mt	
12-54			11-026		
CAM ÇİTASI-4 mm GLAZING BEAD PROFILE	AĞIRLIK / Weight 0,326 kg/mt		CAM ÇİTASI-26 mm GLAZING BEAD PROFILE	AĞIRLIK / Weight 0,296 kg/mt	
11-52			11-028		
CAM ÇİTASI-6 mm GLAZING BEAD PROFILE	AĞIRLIK / Weight 0,279 kg/mt		CAM ÇİTASI-28 mm GLAZING BEAD PROFILE	AĞIRLIK / Weight 0,302 kg/mt	
12-52			11-030		
PERVAZ MONTAJ PROFİLİ BORDER FIXING PROFILE	AĞIRLIK / Weight 0,177 kg/mt		CAM ÇİTASI-30 mm GLAZING BEAD PROFILE	AĞIRLIK / Weight 0,308 kg/mt	
11-004			11-032		
CAM ÇİTASI-4 mm GLAZING BEAD PROFILE	AĞIRLIK / Weight 0,181 kg/mt		CAM ÇİTASI-32 mm GLAZING BEAD PROFILE	AĞIRLIK / Weight 0,315 kg/mt	
11-106			11-035		
CAM ÇİTASI-6 mm GLAZING BEAD PROFILE	AĞIRLIK / Weight 0,200 kg/mt		CAM ÇİTASI-35 mm GLAZING BEAD PROFILE	AĞIRLIK / Weight 0,323 kg/mt	
11-010			11-038		
CAM ÇİTASI-10 mm GLAZING BEAD PROFILE	AĞIRLIK / Weight 0,233 kg/mt		CAM ÇİTASI-38 mm GLAZING BEAD PROFILE	AĞIRLIK / Weight 0,334 kg/mt	
11-015			10-010106-00		
CAM ÇİTASI-15 mm GLAZING BEAD PROFILE	AĞIRLIK / Weight 0,241 kg/mt		KÖŞE TAKOZU-10,6 mm CORNER JOINT	AĞIRLIK / Weight 2,653 kg/mt	
11-017			10-010140-00		
CAM ÇİTASI-17 mm GLAZING BEAD PROFILE	AĞIRLIK / Weight 0,250 kg/mt		KÖŞE TAKOZU-14,2 mm CORNER JOINT	AĞIRLIK / Weight 3,582 kg/mt	
11-020			10-010225-00		
CAM ÇİTASI-20 mm GLAZING BEAD PROFILE	AĞIRLIK / Weight 0,276 kg/mt		KÖŞE TAKOZU-22,5 mm CORNER JOINT	AĞIRLIK / Weight	

# LS70 - 1,8mm



















YALITIMLI KALDIR-SÜR SİSTEMİ  
THERMAL LIFT&SLIDE SYSTEM

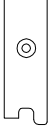



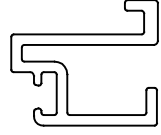

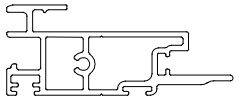

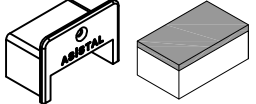

PROFİL LİSTESİ - PROFILE LIST

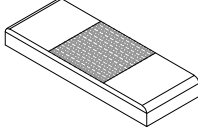
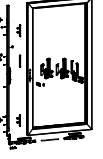
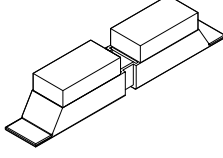
LS60 71				
KÖŞE TAKOZU-14,2 mm CORNER JOINT	AĞIRLIK / Weight			
	2,050 kg/mt			
LS60 72				
KÖŞE TAKOZU-22,5 mm CORNER JOINT	AĞIRLIK / Weight			
	0,420 kg/mt			

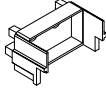
### AKSESUAR LİSTESİ - ACCESSORIES LIST

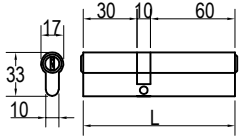
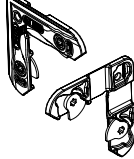
EP1-01			TRI-FIN-700		
DİŞ CAM FİTİLİ - 2,5 mm OUTER GLAZING GASKET	KOLİ MİKTARI/Package 240 mt / 15 kg		3 YAPRAKLI KIL FİTİL -7mm TRI-BRUSH GASKET	KOLİ MİKTARI/Package 400 mt / koli	
EP2-01			KF 67-600		
İÇ CAM FİTİLİ - 3 mm INNER GLAZING GASKET	KOLİ MİKTARI/Package 440 mt / 15 kg		FİRÇA FİTİL-6mm BRUSH GASKET	KOLİ MİKTARI/Package 1300 mt / koli	
EP2-02			KF 67-700		
İÇ CAM FİTİLİ - 4 mm INNER GLAZING GASKET	KOLİ MİKTARI/Package 300 mt / 15 kg		FİRÇA FİTİL-7mm BRUSH GASKET	KOLİ MİKTARI/Package 1100 mt / koli	
EP2-03			KF 67-1000		
İÇ CAM FİTİLİ - 5 mm INNER GLAZING GASKET	KOLİ MİKTARI/Package 250 mt / 15 kg		FİRÇA FİTİL-10mm BRUSH GASKET	KOLİ MİKTARI/Package 600 mt / koli	
EP38-02			MO70-03		
KASA KANAL FİTİLİ FRAME GASKET	KOLİ MİKTARI/Package 535 mt / 15 kg		MO70-10 İÇİN KAPAK-ALT COVER FOR MO60-10-BOTTOM	KOLİ MİKTARI/Package Adet / Piece	
EP70-02			MO70-04		
KASA FİTİLİ FRAME GASKET	KOLİ MİKTARI/Package 500 mt / 15 kg		MO70-10 İÇİN KAPAK-ÜST COVER FOR MO60-10-TOP	KOLİ MİKTARI/Package Adet / Piece	
EP38 -01			MO70-08		
KANAT FİTİLİ SASH GASKET	KOLİ MİKTARI/Package 500 mt / 15 kg		KASA YALITIM PVC FRAME ISOLATION GASKET	KOLİ MİKTARI/Package 6 mt / Adet	
C60-04			MO70-09		
KANAL FİTİLİ ADAPTER GASKET- 480.ALM.S	KOLİ MİKTARI/Package 100 mt / 15 kg		DAR ORTA KENET YALITIM FİTİLİ - PVC CENTRAL LOCKING SEALING GASKET-PVC	KOLİ MİKTARI/Package 6 mt / Adet	
EP60-04			MO70-10		
KENET FİTİLİ CENTRAL LOCKING GASKET	KOLİ MİKTARI/Package 300 mt / koli		ORTA KENET YALITIM FİTİLİ - PVC CENTRAL LOCKING SEALING GASKET-PVC	KOLİ MİKTARI/Package 6 mt / Adet	
EP70-03			MO70-01		
SABİT ÇITA FİTİLİ Fixed Frame Gasket	KOLİ MİKTARI/Package - mt / koli		KENET KAPAĞI INTERLOCK ADAPTOR FOAM	KOLİ MİKTARI/Package Adet / Piece	

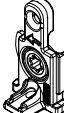
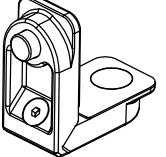
### AKSESUAR LİSTESİ - ACCESSORIES LIST

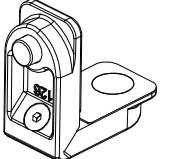
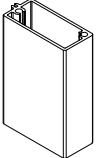
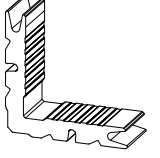
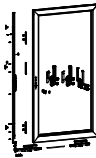
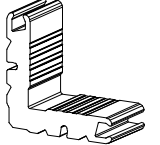
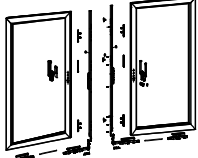
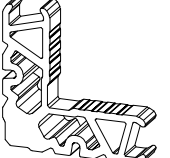
<b>MO70-05</b>			<b>LS60-MEK2</b>		
HAVA KESİCİ CENTRAL SEALING-TOP	KOLİ MİKTARI/Package Adet / Piece		200 kg KAPASİTELİ KALDIR-SÜR MEKANİZMA LIFT & SLIDE MECHANISM	KOLİ MİKTARI/Package Takım / Set	
<b>MO60-05D</b>			<b>LS60-MEK2D</b>		
ALT HAVA KESİCİ LS70 08 KASA İÇİN CENTRAL SEALING-BOTTOM FOR LS70 08	KOLİ MİKTARI/Package Adet / Piece		200 kg KAPASİTELİ 4'LÜ KANAT MEKANİZMA LIFT & SLIDE MECHANISM	KOLİ MİKTARI/Package Takım / Set	
<b>MO70-12</b>			<b>ASI-LS-H01</b>		
4 LÜ KANAT KİLİTLEME ADAPTÖR KAPAĞI MEETING STILE CAP	KOLİ MİKTARI/Package Adet / Piece		KALDIR-SÜR KOLU LIFT&SLIDE HANDLE	KOLİ MİKTARI/Package Takım / Set	
<b>ASI-WDC 01</b>			<b>ASI-BRL 100</b>		
YAĞMUR TAHLİYE KAPAĞI WATER REJECT COVER	KOLİ MİKTARI/Package Adet / Piece		100 LUK BAREL CYLINDER 100	KOLİ MİKTARI/Package Adet / Piece	
<b>ASI-FUJI 2500</b>			<b>ASI-SB 19.1</b>		
AYARLI ORTA KAYIT BAĞLANTI T JOINT CONNECTION	KOLİ MİKTARI/Package Adet / Piece		KÖŞE GÖNYESİ CORNER ALIGNMENT	KOLİ MİKTARI/Package 1000 Adet / Piece	
<b>ASI-FUJI 2700</b>			<b>ASI-PB 1119</b>		
AYARLI ORTA KAYIT BAĞLANTI T JOINT CONNECTION	KOLİ MİKTARI/Package Adet / Piece		PİMLİ KÖŞE BAĞLANTI CORNER JOINT	KOLİ MİKTARI/Package Adet / Piece	
<b>MO60-19</b>			<b>ASI-PB 1126</b>		
KOL PROFİL KAPAĞI HANDLE PROFILE CAP	KOLİ MİKTARI/Package alt-üst takım / set		PİMLİ KÖŞE BAĞLANTI CORNER JOINT	KOLİ MİKTARI/Package Adet / Piece	
<b>LS60-DB 3560</b>			<b>ASI-KT 1126</b>		
KANAT SABİTLEME PARÇASI SASH FIXING	KOLİ MİKTARI/Package Adet / Piece		KÖŞE TAKOZU CORNER JOINT	KOLİ MİKTARI/Package Adet / Piece	
<b>LS60-MEK1</b>			<b>ASI-KT 1429</b>		
300 kg KAPASİTELİ KALDIR-SÜR MEKANİZMA LIFT & SLIDE MECHANISM	KOLİ MİKTARI/Package Takım / Set		KÖŞE TAKOZU CORNER JOINT	KOLİ MİKTARI/Package Adet / Piece	
<b>LS60-MEK1D</b>			<b>ASI-KT 2307</b>		
300 kg KAPASİTELİ 4'LÜ KANAT MEKANİZMA LIFT & SLIDE MECHANISM	KOLİ MİKTARI/Package Takım / Set		KÖŞE TAKOZU CORNER JOINT	KOLİ MİKTARI/Package Adet / Piece	



**LS70 - 1,8mm**

YALITIMLI KALDIR-SÜR SİSTEMİ  
THERMAL LIFT&SLIDE SYSTEM

**ASISTAL**

**PROFİL DETAYLARI**  
*PROFILE DETAILS*



# LS70 - 1,8mm

YALITIMLI KALDIR-SÜR SİSTEM  
THERMAL LIFT&SLIDE SYSTEM

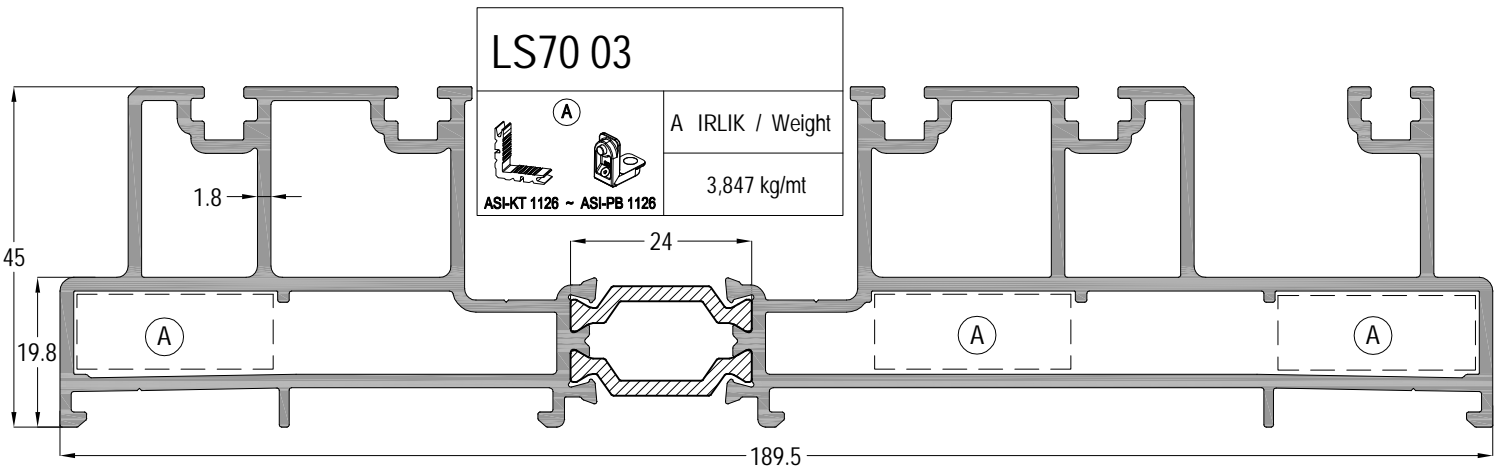
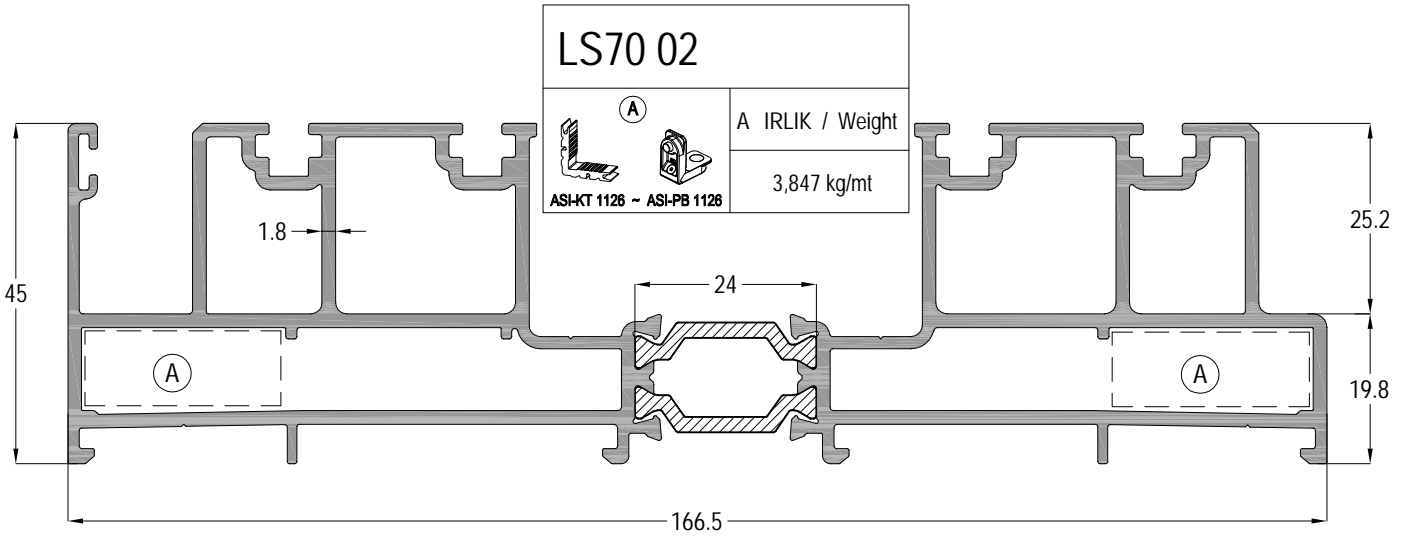
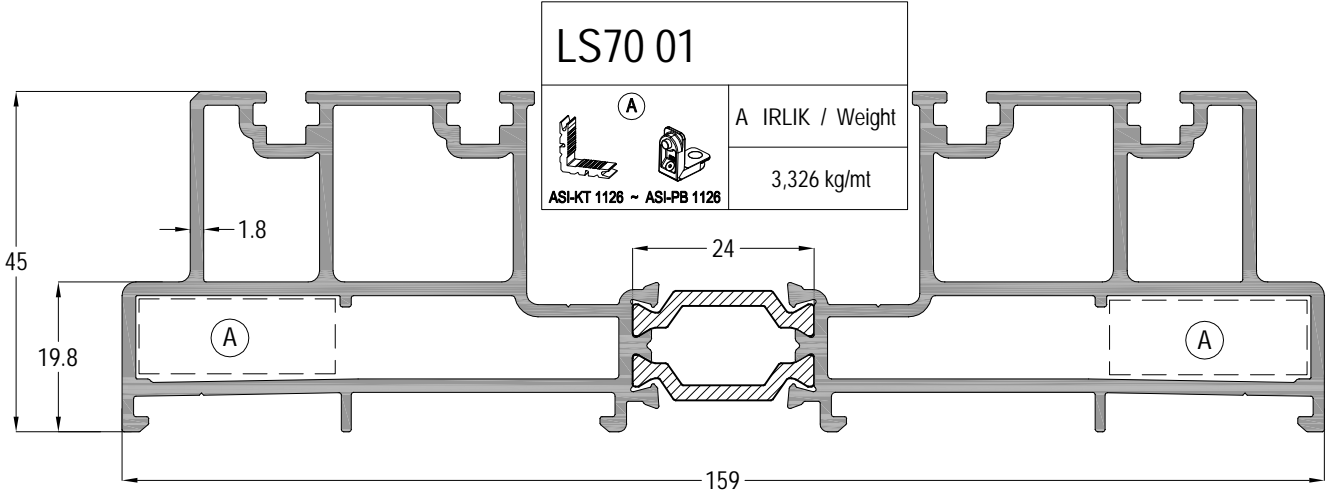

Profil ağırlıklarımız teorik olup; teslim anındaki tartımız geçerlidir.  
Profile weights are theoretical and the weight at the time of delivery is valid.

# LS70 - 1,8mm

YALITIMLI KALDIR-SÜR SİSTEM  
THERMAL LIFT&SLIDE SYSTEM



## LS70 04

 ASI-KT 1126 ~ ASI-PB 1126	A IRLIK / Weight 4,054 kg/mt
----------------------------------------------------------------------------------------------------------------	---------------------------------

## LS70 05

 ASI-KT 1126 ~ ASI-PB 1126	A IRLIK / Weight 5,181 kg/mt
-----------------------------------------------------------------------------------------------------------------	---------------------------------

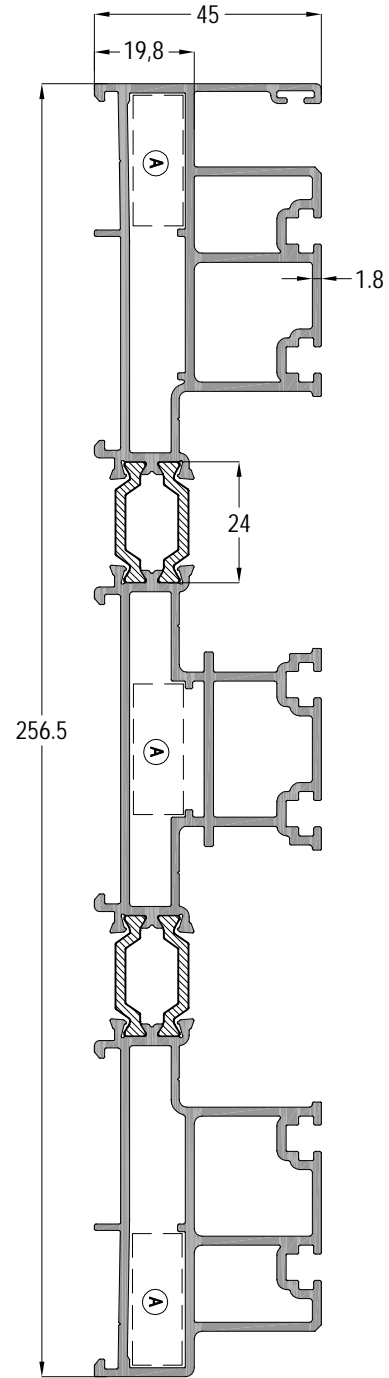
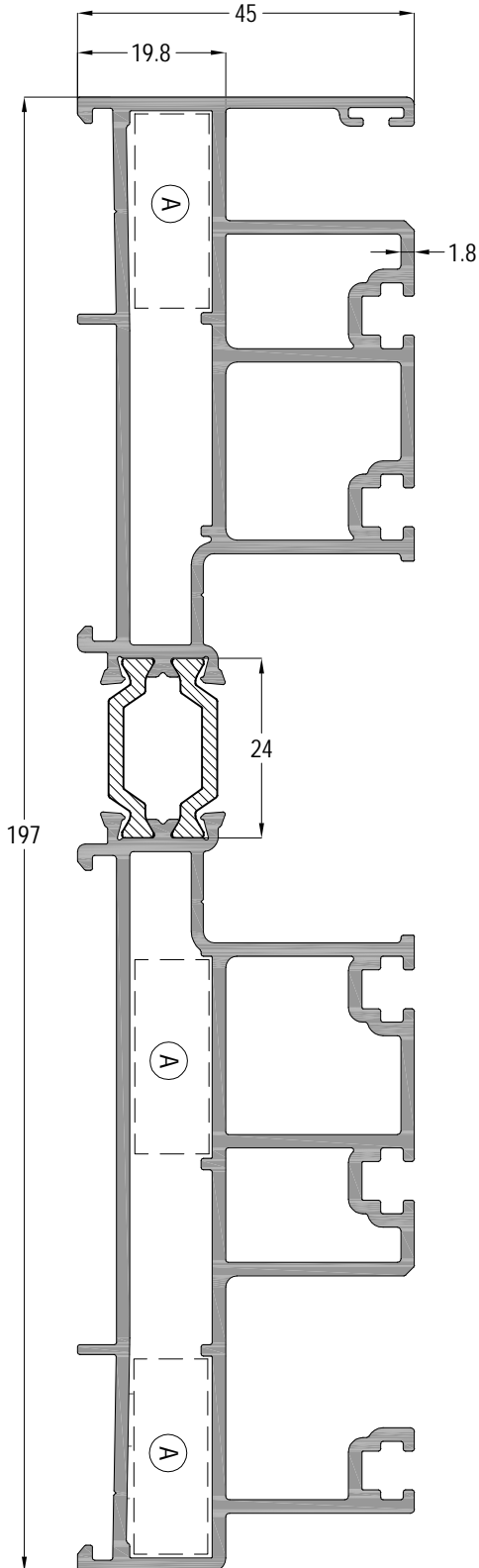

SC:2/3

Profil ağırlıklarımız teorik olup; teslim anındaki tartımız geçerlidir.  
Profile weights are theoretical and the weight at the time of delivery is valid.

# LS70 - 1,8mm

YALITIMLI KALDIR-SÜR SİSTEM  
THERMAL LIFT&SLIDE SYSTEM



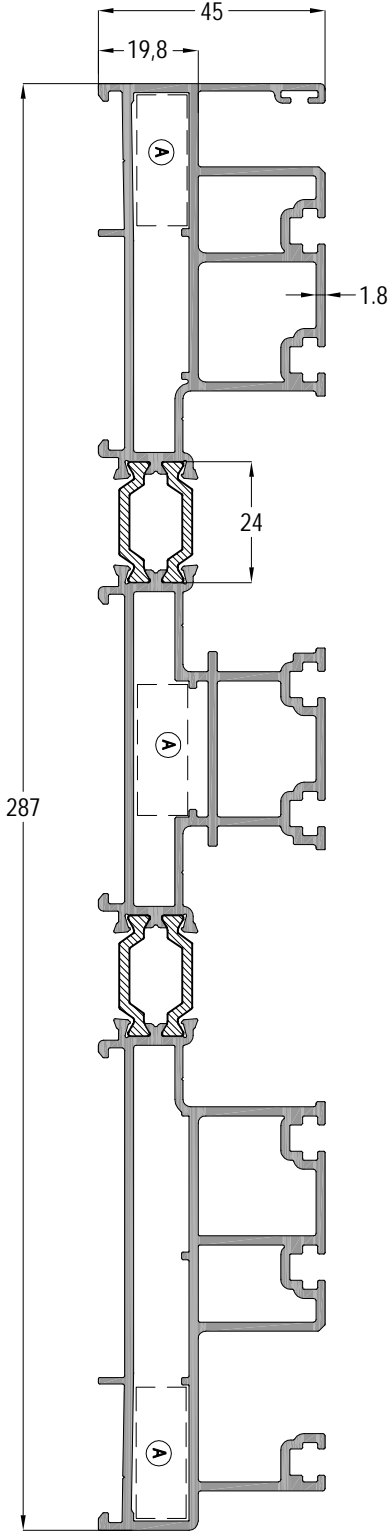

## LS70 06

 ASI-KT 1126 ~ ASI-PB 1126	A İRLİK / Weight 5,703 kg/mt
----------------------------------------------------------------------------------------------------------------	---------------------------------



SC:2/3

## LS70 11

 ASI-KT 1429	 ASI-KT 2307	 ASI-SB 19.1	AĞIRLIK / Weight 2,314 kg/mt
---------------------------------------------------------------------------------------------------	----------------------------------------------------------------------------------------------------	----------------------------------------------------------------------------------------------------	---------------------------------

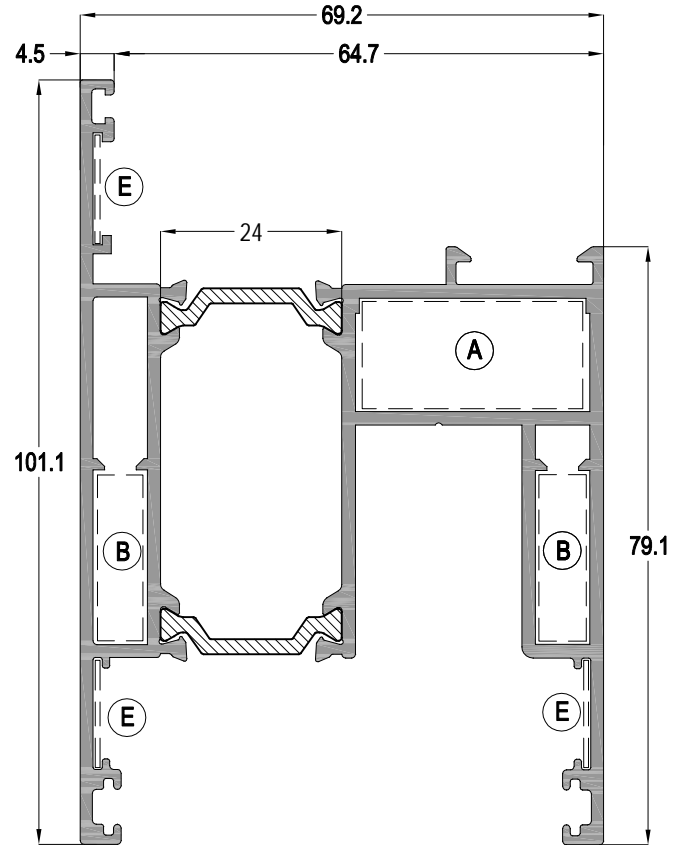

## LS70 08

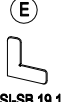
 ASI-KT 1126 ~ ASI-PB 1126	 ASI-SB 19.1	AĞIRLIK / Weight 2,735 kg/mt
-------------------------------------------------------------------------------------------------------------------	------------------------------------------------------------------------------------------------------	---------------------------------

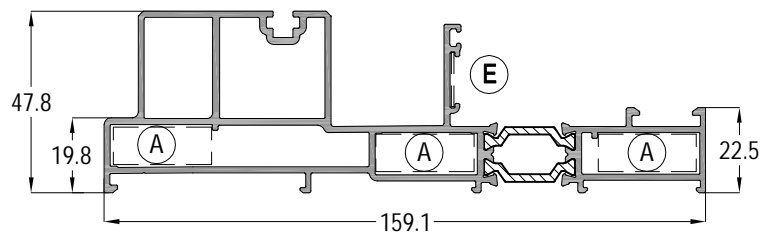



SC:1/2

Profil ağırlıklarımız teorik olup; teslim anındaki tartımız geçerlidir.  
Profile weights are theoretical and the weight at the time of delivery is valid.

# LS70 - 1,8mm



YALITIMLI KALDIR-SÜR SİSTEM  
THERMAL LIFT&SLIDE SYSTEM

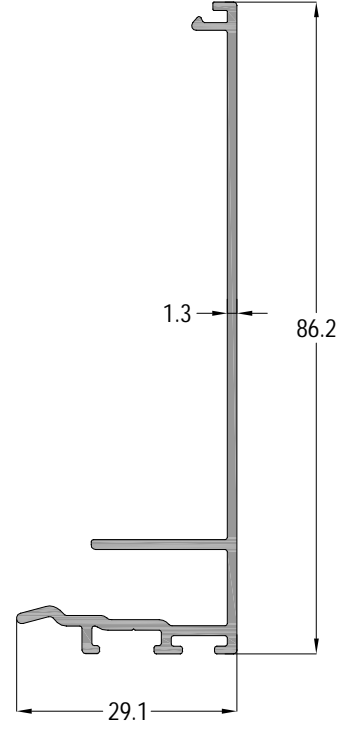
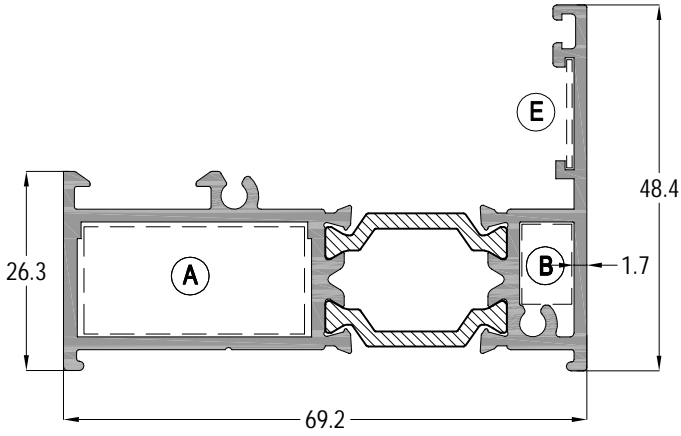

LS70 12			
			AĞIRLIK / Weight
ASI-KT 1126 ~ ASI-PB 1126	ASI-KT 1106	ASI-SB 19.1	1,282 kg/mt

LS70 44
0,531 kg/mt



LS70 13			
			AĞIRLIK / Weight
ASI-KT 1126 ~ ASI-PB 1126	ASI-KT 1106	ASI-SB 19.1	1,961 kg/mt

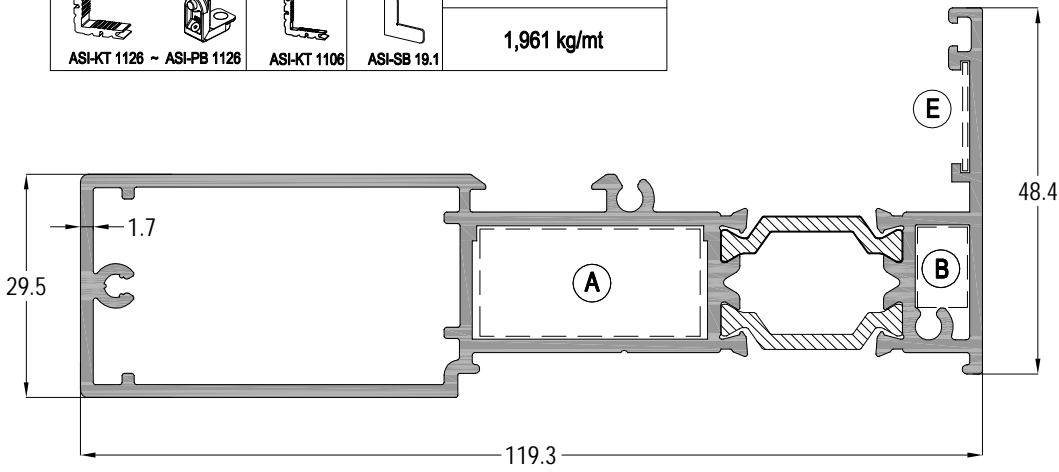

# LS70 - 1,8mm

YALITIMLI KALDIR-SÜR SİSTEM  
THERMAL LIFT&SLIDE SYSTEM

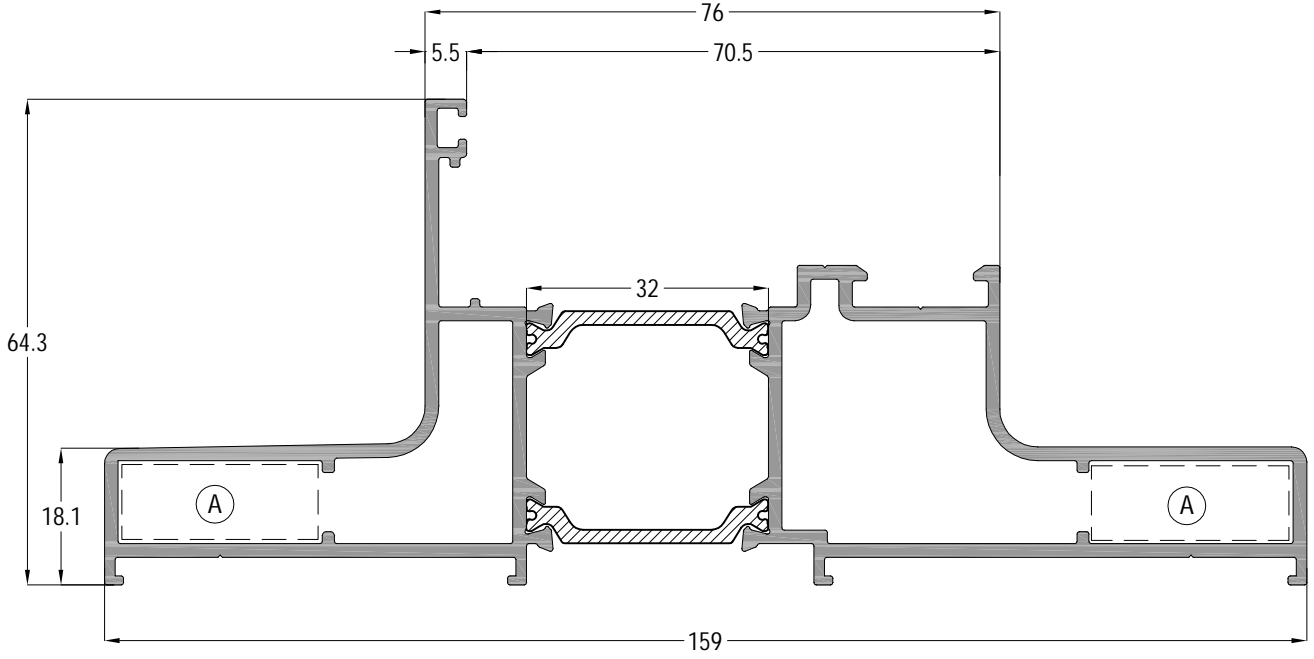

## LS70 78

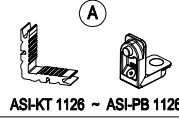

A İRLİK / Weight

2,467 kg/mt

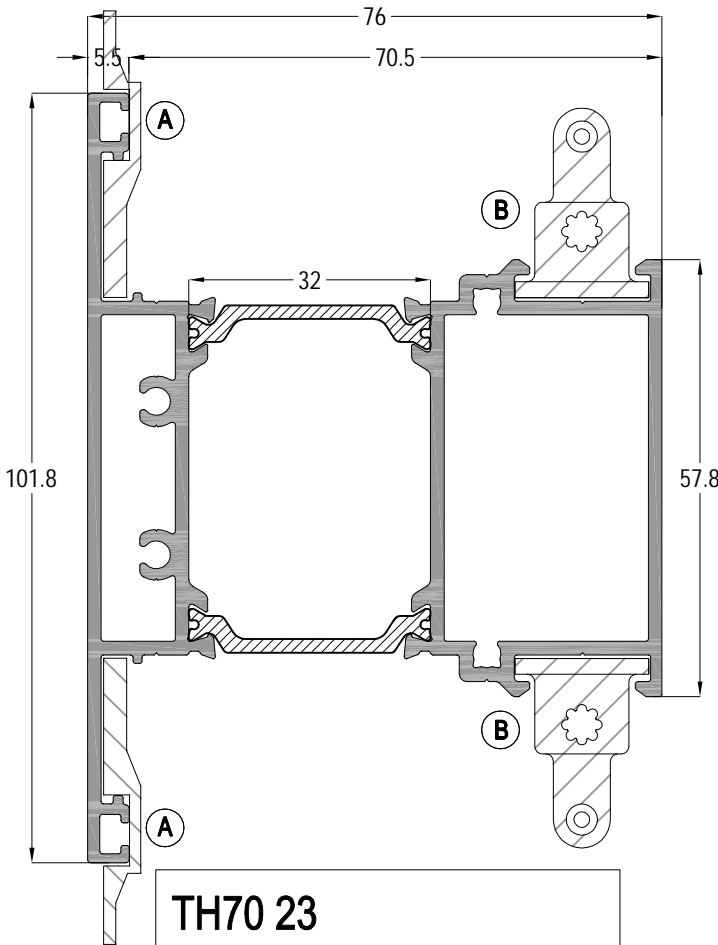

## TH70 23

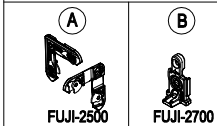

AĞIRLIK / Weight

2,203 kg/mt

## TH70 43

AĞIRLIK / Weight

0,568 kg/mt

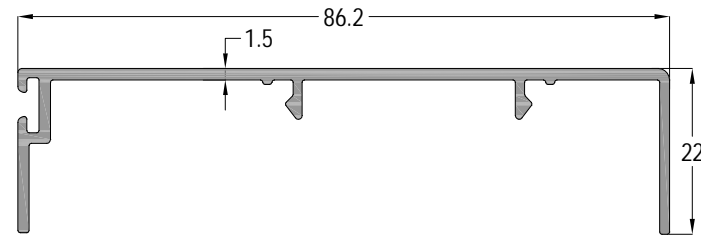

Profil ağırlıklarımız teorik olup; teslim anındaki tartımız geçerlidir.  
Profile weights are theoretical and the weight at the time of delivery is valid.

# LS70 - 1,8mm

YALITIMLI KALDIR-SÜR S STEM  
THERMAL LIFT&SLIDE SYSTEM

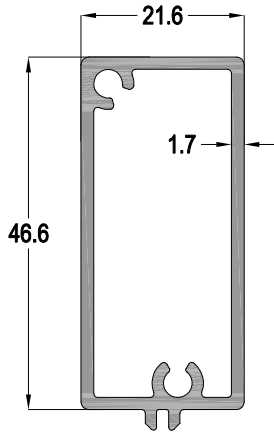

**LS60 35**

0,672 kg/mt

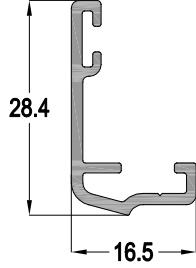

**LS70 61**

0,231 kg/mt

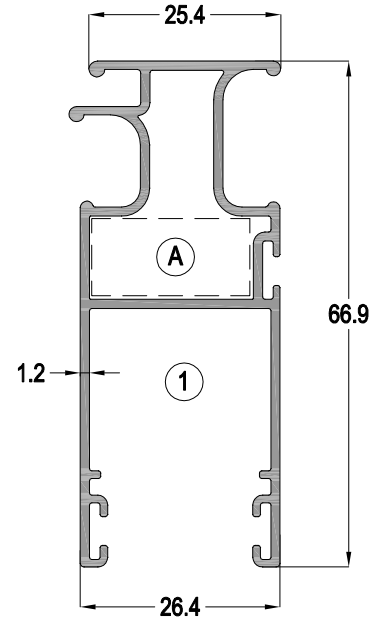

**13-09986**



ASI-PB 1119



ASI-SR 01R

**AĞIRLIK / Weight**

0,741 kg/mt

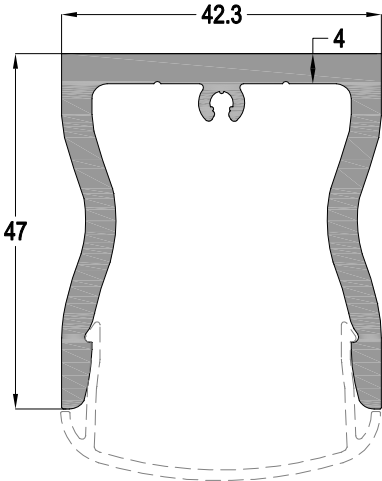

**LS60 71**

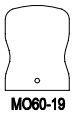

MO60-19

**AĞIRLIK / Weight**

2,050 kg/mt

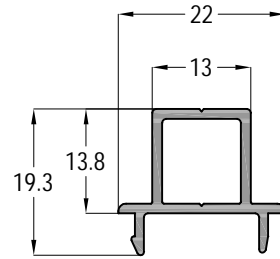

**SL32 43**

0,235 Kg/mt

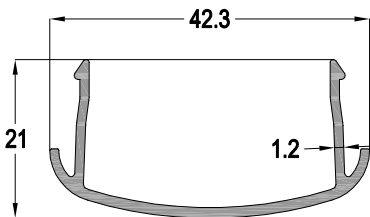

**LS60 72**

0,420 kg/mt

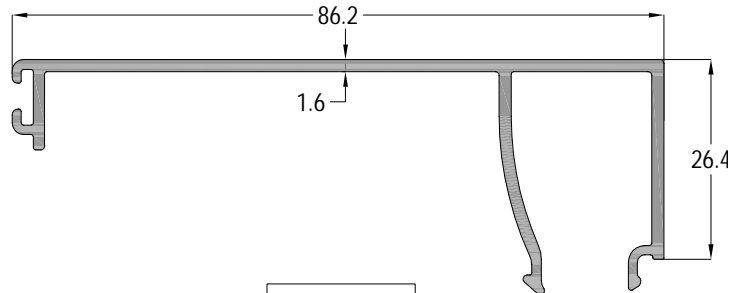

**LS70 40**

0,694 kg/mt

Profil a ırıklarımız teorik olup; teslim anındaki tartımız geçerlidir.  
Profile weights are theoretical and the weight at the time of delivery is valid.

# LS70 - 1,8mm

YALITIMLI KALDIR-SÜRÜS SİSTEMİ  
THERMAL LIFT&SLIDE SYSTEM

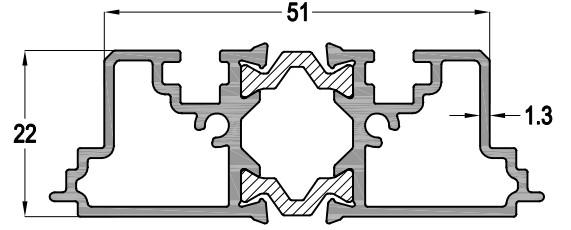
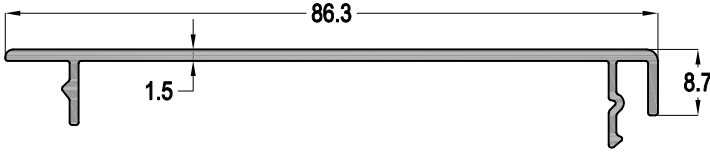

## LS70 41

	AĞIRLIK / Weight
	0,441 kg/mt

## LS70 42

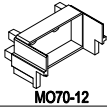
 MO70-12	AĞIRLIK / Weight
	1,001 kg/mt

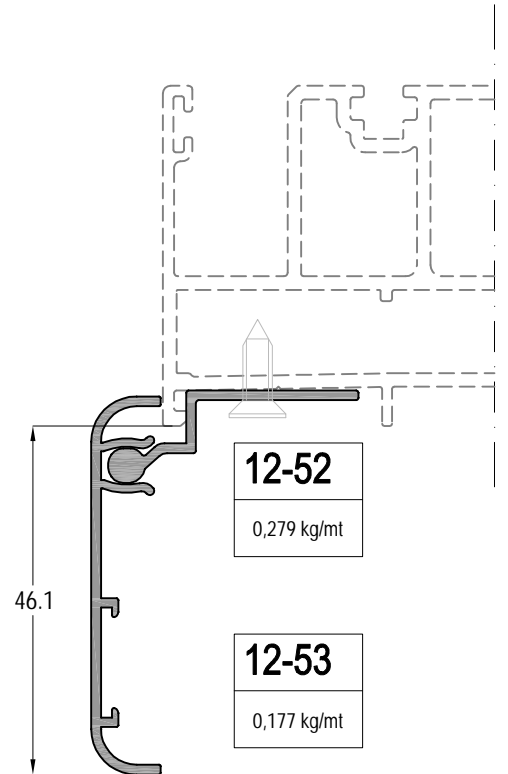
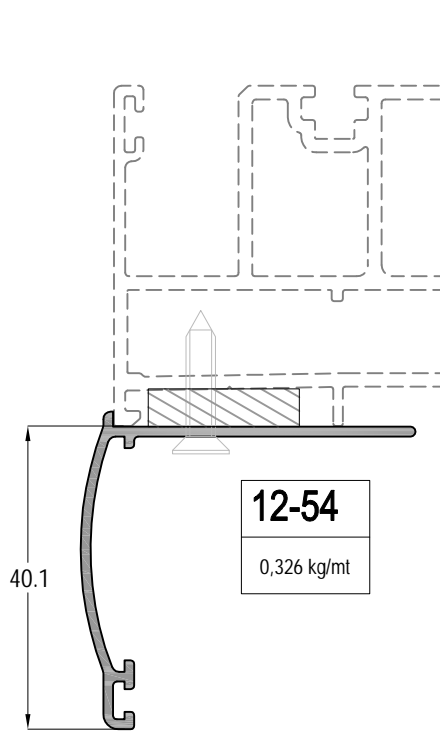
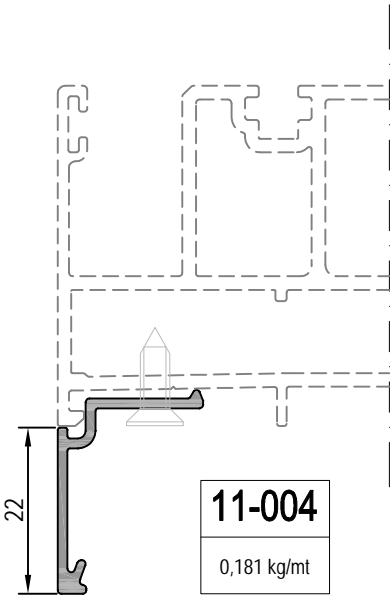

# LS70 - 1,8mm

YALITIMLI KALDIR-SÜR SİSTEM  
THERMAL LIFT&SLIDE SYSTEM

## ASISTAL

11-106

0,200 kg/mt

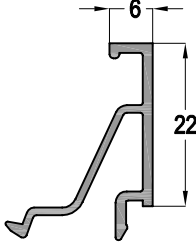

11-010

0,233 kg/mt

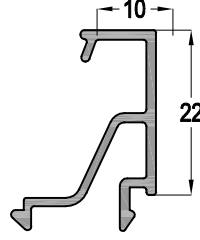

11-015

0,241 kg/mt

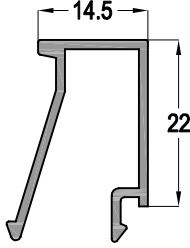

11-017

0,250 kg/mt

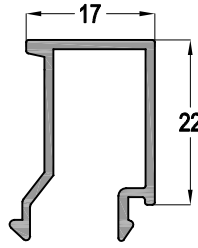

11-020

0,276 kg/mt

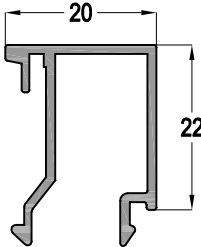

11-022

0,282 kg/mt

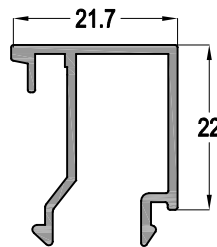

11-026

0,296 kg/mt

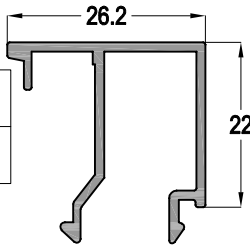

11-028

0,302 kg/mt

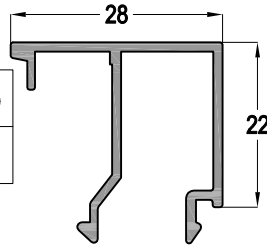

11-030

0,308 kg/mt

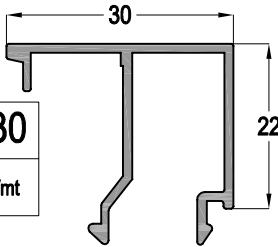

11-032

0,315 kg/mt

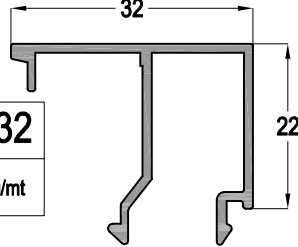

11-035

0,323 kg/mt

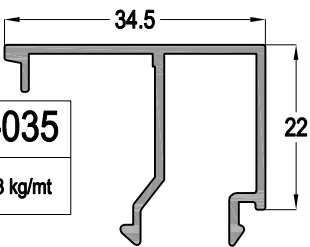

11-038

0,334 kg/mt

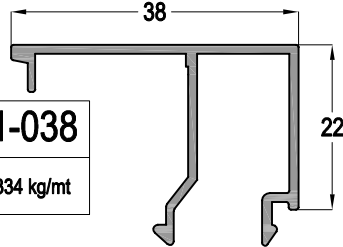

CAM KALINLIĞINA GÖRE CAM ÇİTASI SEÇİM TABLOSU  
Glazing Bead Selection Table according to the Glass  
Thickness (LS70-11)

CAM KALINLIĞI Glass Thickness (mm)	CAM ÇİTASI Glazing Bead	İÇ CAM FİTİLİ Glass Gasket (IN)	DIŞ CAM FİTİLİ Glass Gasket (OUT)
18	11-038	EP2-03	EP1-01
19	11-038	EP2-02	EP1-01
20	11-038	EP2-01	EP1-01
21	11-035	EP2-03	EP1-01
22	11-035	EP2-02	EP1-01
23	11-035	EP2-01	EP1-01
24	11-032	EP2-03	EP1-01
25	11-032	EP2-02	EP1-01
26	11-032	EP2-01	EP1-01
27	11-030	EP2-02	EP1-01
28	11-030	EP2-01	EP1-01
29	11-028	EP2-02	EP1-01
30	11-028	EP2-01	EP1-01
31	11-026	EP2-02	EP1-01
32	11-026	EP2-01	EP1-01
34	11-022	EP2-03	EP1-01
35	11-022	EP2-02	EP1-01
36	11-022	EP2-01	EP1-01
38	11-020	EP2-01	EP1-01
39	11-017	EP2-03	EP1-01
40	11-017	EP2-02	EP1-01
42	11-015	EP2-02	EP1-01
43	11-015	EP2-01	EP1-01
46	11-010	EP2-03	EP1-01
47	11-010	EP2-02	EP1-01
48	11-010	EP2-01	EP1-01
50	11-006	EP2-03	EP1-01
52	11-006	EP2-01	EP1-01

Profil ağırlıklarımız teorik olup; teslim anındaki tartımız geçerlidir.  
Profile weights are theoretical and the weight at the time of delivery is valid.



# LS70 - 1,8mm

YALITIMLI KALDIR-SÜR SİSTEM  
THERMAL LIFT&SLIDE SYSTEM

## ASISTAL

11-010

0,233 kg/mt

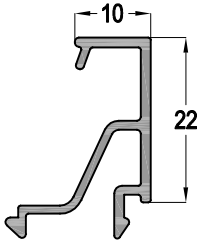

11-015

0,241 kg/mt

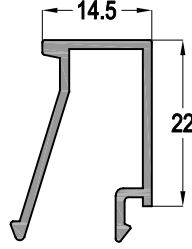

11-017

0,250 kg/mt

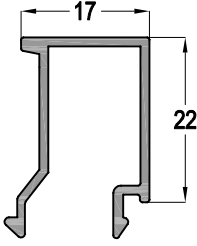

11-020

0,276 kg/mt

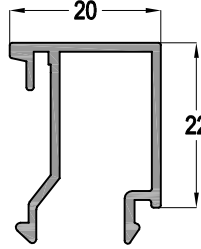

11-022

0,282 kg/mt

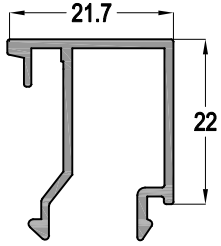

11-026

0,296 kg/mt

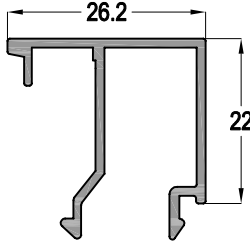

11-028

0,302 kg/mt

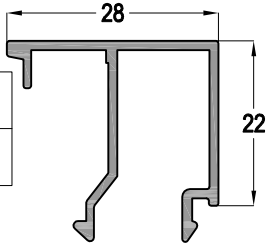

11-030

0,308 kg/mt

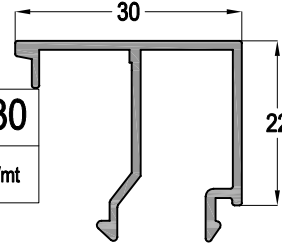

11-032

0,315 kg/mt

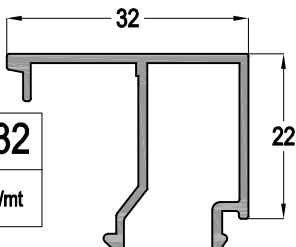

11-035

0,323 kg/mt

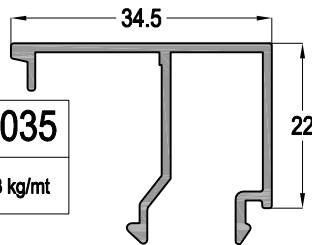

11-038

0,334 kg/mt

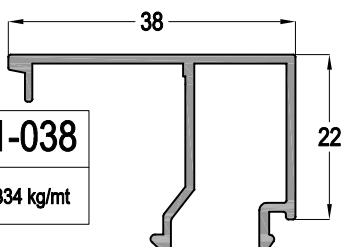

11-144

0,339 kg/mt

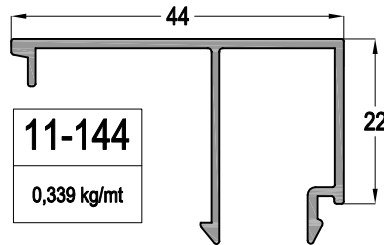

CAM KALINLIĞINA GÖRE CAM ÇİTASI SEÇİM TABLOSU  
Glazing Bead Selection Table according to the Glass  
Thickness (TH70 23-TH7018)

CAM KALINLIĞI Glass Thickness (mm)	CAM ÇİTASI Glazing Bead	İÇ CAM FİTLİ Glass Gasket (IN)	DIŞ CAM FİTLİ Glass Gasket (OUT)
18	11-044	EP2-03	EP1-01
19	11-044	EP2-02	EP1-01
20	11-044	EP2-01	EP1-01
24	11-038	EP2-03	EP1-01
25	11-038	EP2-02	EP1-01
26	11-038	EP2-01	EP1-01
27	11-035	EP2-03	EP1-01
28	11-035	EP2-02	EP1-01
29	11-035	EP2-01	EP1-01
30	11-032	EP2-03	EP1-01
31	11-032	EP2-02	EP1-01
32	11-032	EP2-01	EP1-01
33	11-030	EP2-02	EP1-01
34	11-030	EP2-01	EP1-01
35	11-028	EP2-02	EP1-01
36	11-026	EP2-02	EP1-01
37	11-026	EP2-01	EP1-01
40	11-022	EP2-03	EP1-01
41	11-022	EP2-02	EP1-01
42	11-022	EP2-01	EP1-01
44	11-020	EP2-01	EP1-01
46	11-017	EP2-02	EP1-01
48	11-015	EP2-02	EP1-01
52	11-010	EP2-03	EP1-01

Profil ağırlıklarımız teorik olup; teslim anındaki tartımız geçerlidir.  
Profile weights are theoretical and the weight at the time of delivery is valid.



## AÇILIM TİPLERİ KALDIR-SÜR SÜRME - OPENING TYPES LIFT & SLIDING

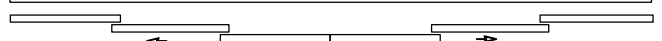
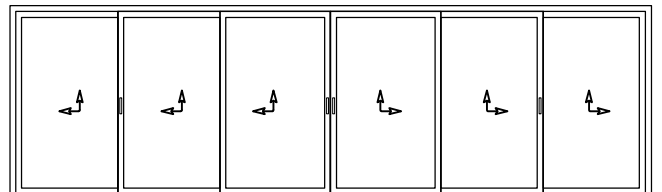
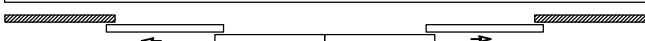
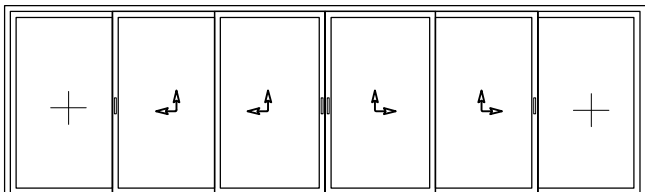
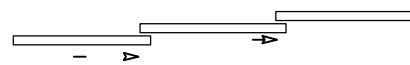
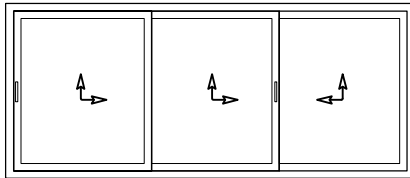
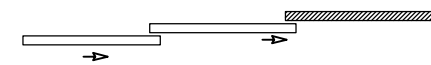
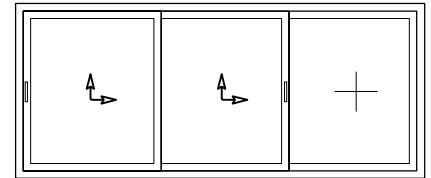
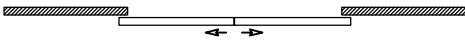
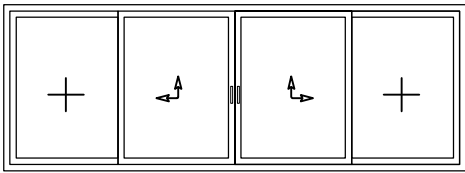
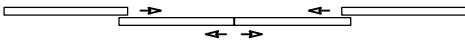
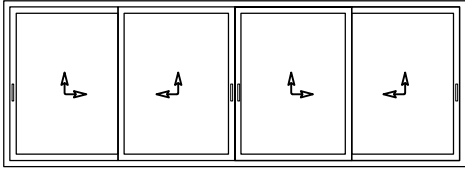
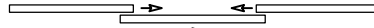
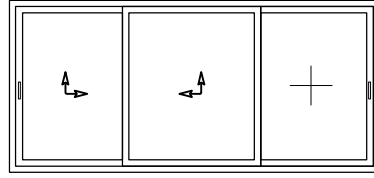
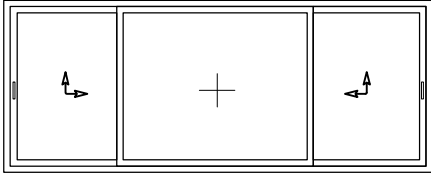
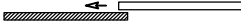
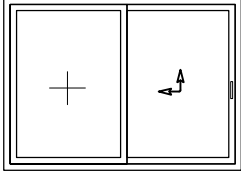
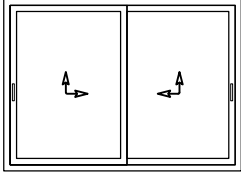

### RÜZGAR YÜKÜNE GÖRE MAKSİMUM KANAT EBATLARI MAXIMUM SASH DIMENSIONS FOR GIVEN WIND PRESSURE

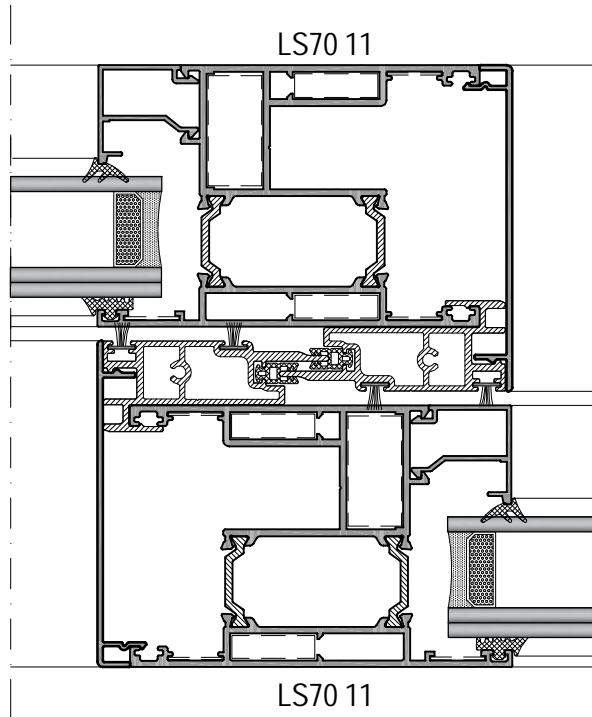
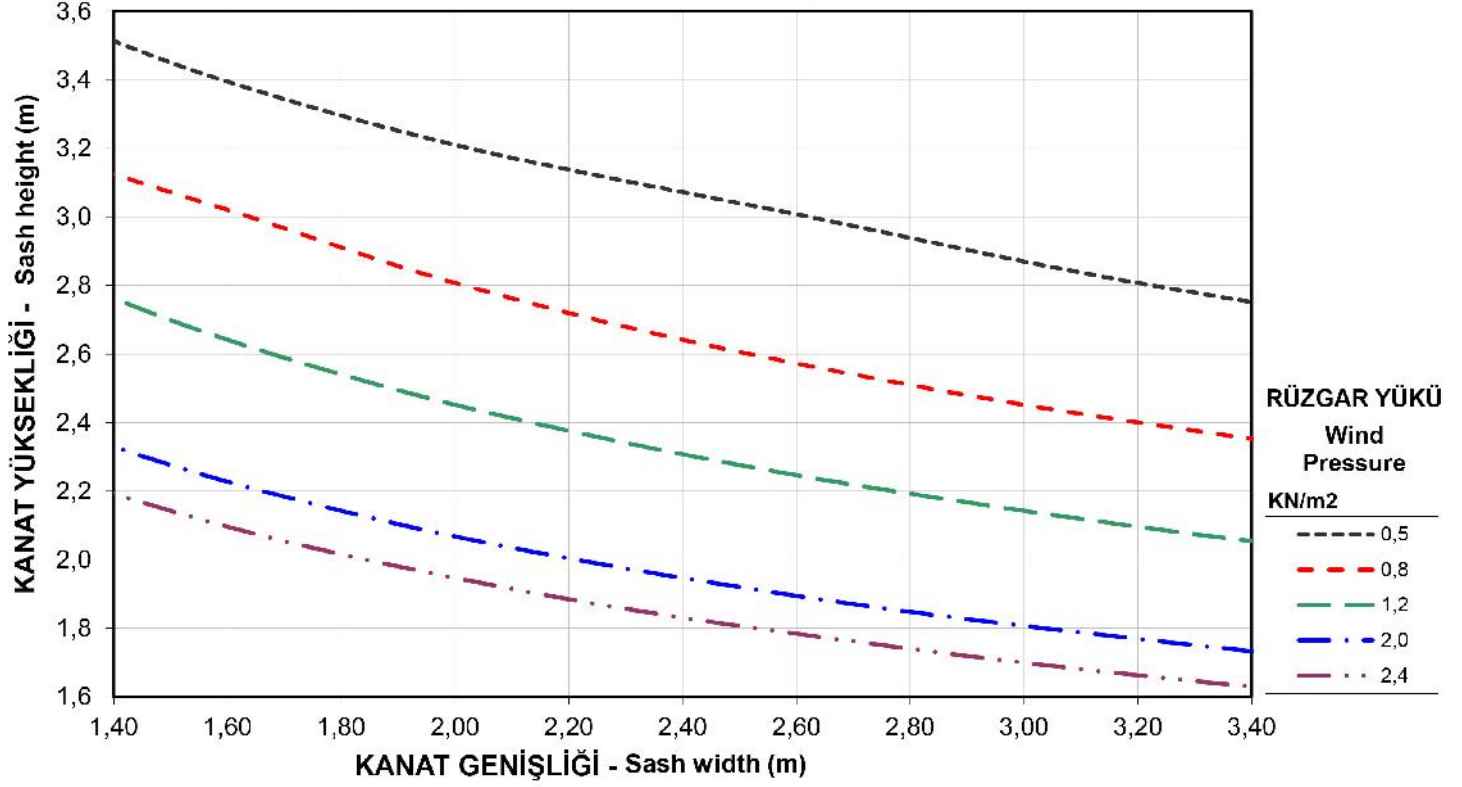

KANAT EBATLARI BELİRLENİRKEN MEKANİZMANIN TAŞIMA KAPASİTESİNİ GEÇMEMESİNE DİKKAT EDİLMELİDİR  
WHILE THE SASH DIMENSIONS DETERMINED, SASH WEIGHT MUST BE LESS THAN ROLLER CARY CAPACITY

### RÜZGAR YÜKÜNE GÖRE MAKSİMUM KANAT EBATLARI MAXIMUM SASH DIMENSIONS FOR GIVEN WIND PRESSURE

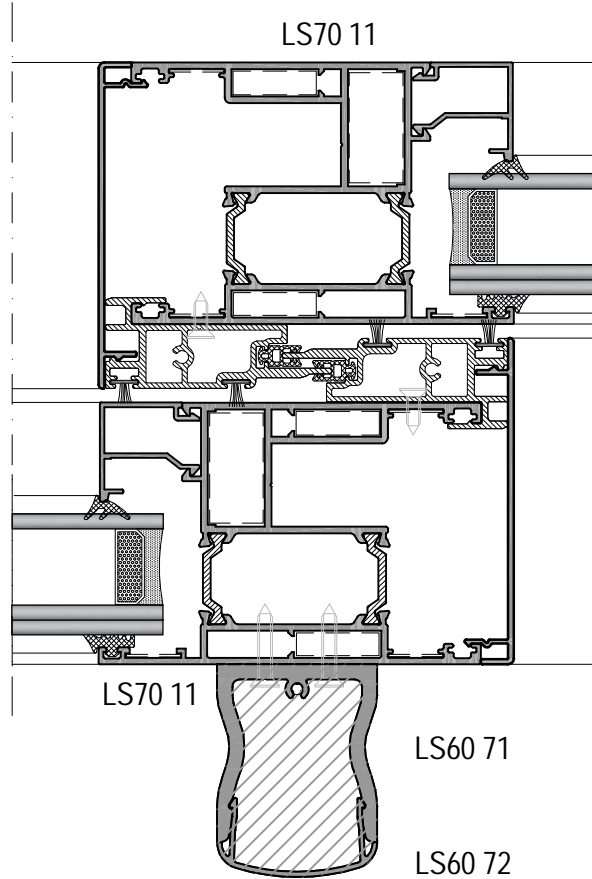
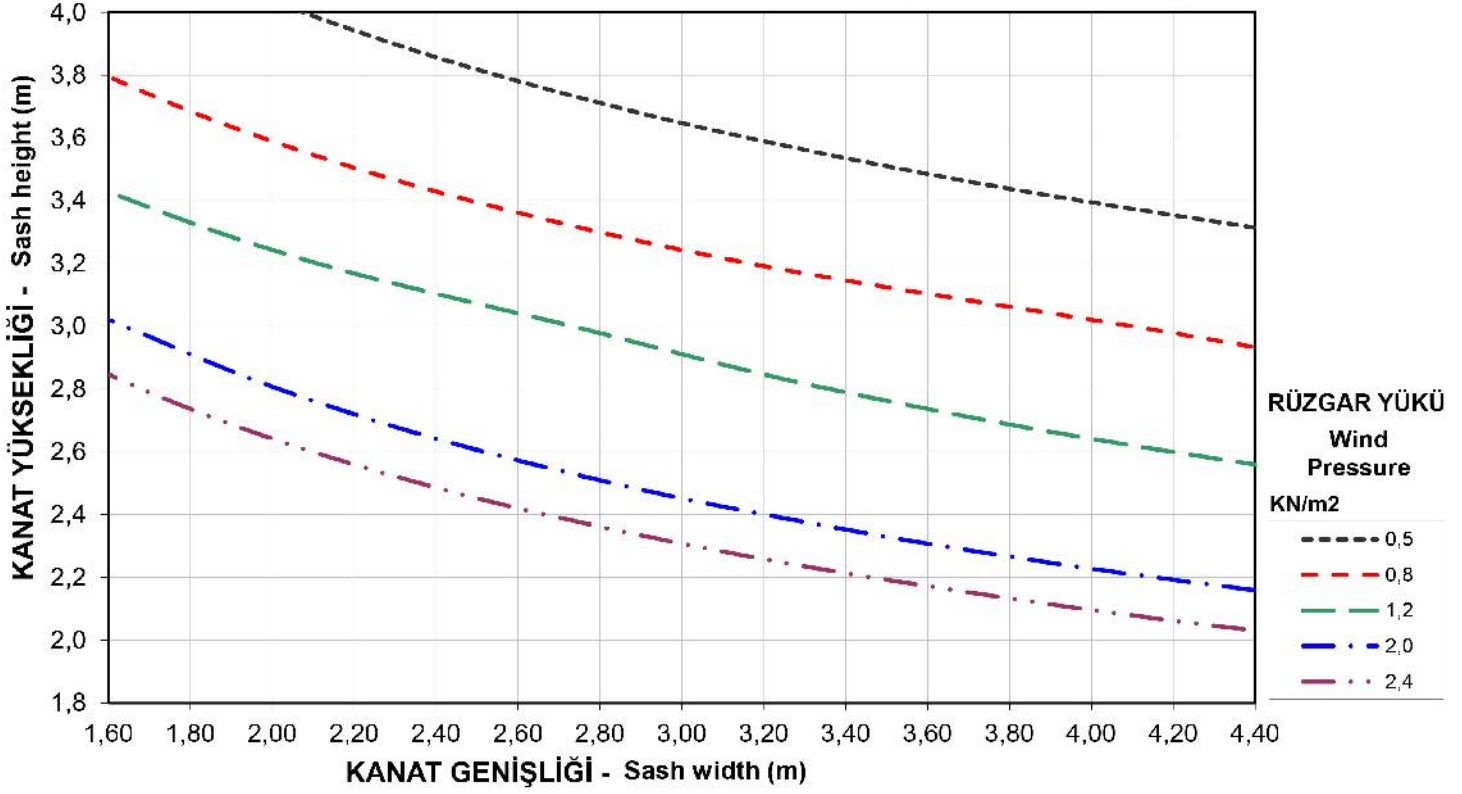

KANAT EBATLARI BELİRLENİRKEN MEKANİZMANIN TAŞIMA KAPASİTESİNİ GEÇMEMESİNE DİKKAT EDİLMELİDİR  
WHILE THE SASH DIMENSIONS DETERMINED, SASH WEIGHT MUST BE LESS THAN ROLLER CARY CAPACITY

**LS70 - 1,8mm**

YALITIMLI KALDIR-SÜR SİSTEMİ  
THERMAL LIFT&SLIDE SYSTEM

**ASISTAL**

**SİSTEM DETAYLARI**  
*SYSTEM DETAILS*

# LS70 - 1,8mm

YALITIMLI KALDIR-SÜR SİSTEM  
THERMAL LIFT&SLIDE SYSTEM

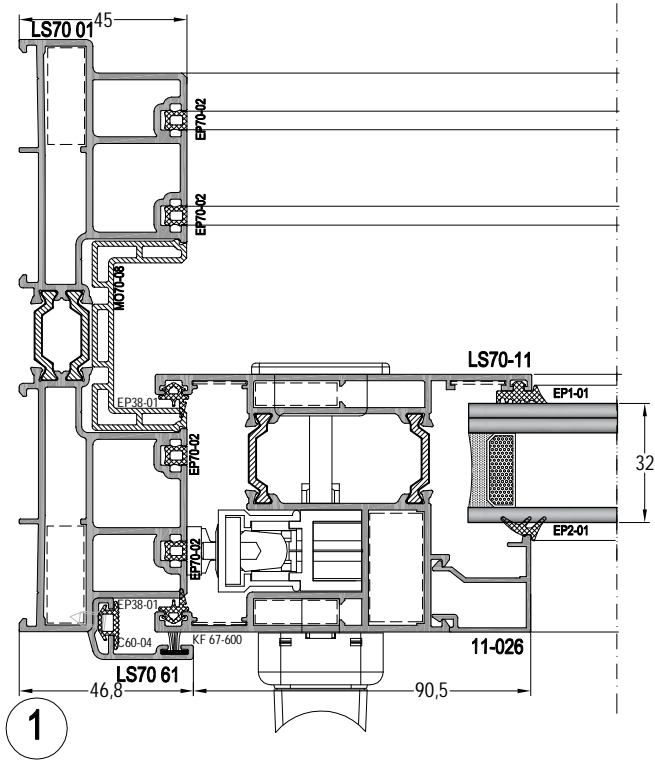

3

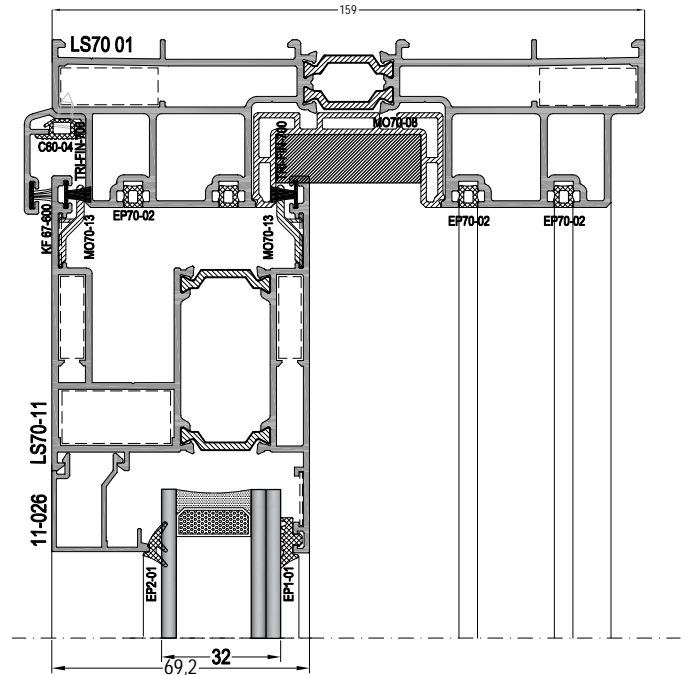

4

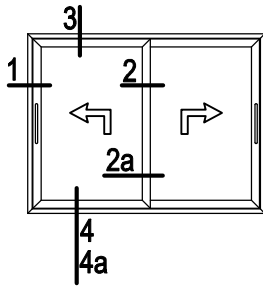

4a

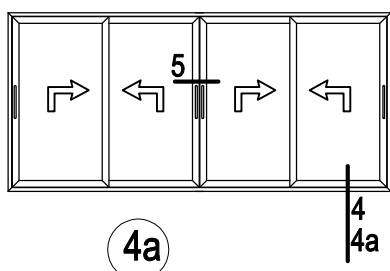

Alternatif Ray Fıtlı  
Alternative Gasket

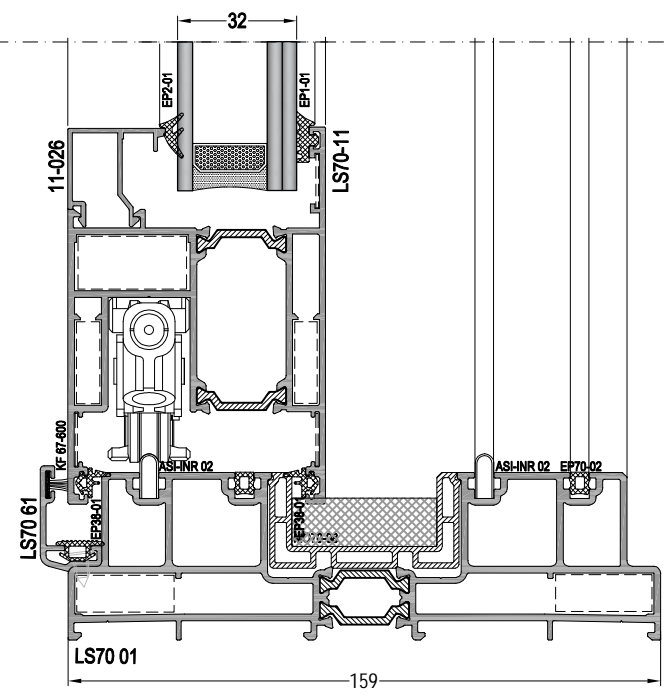
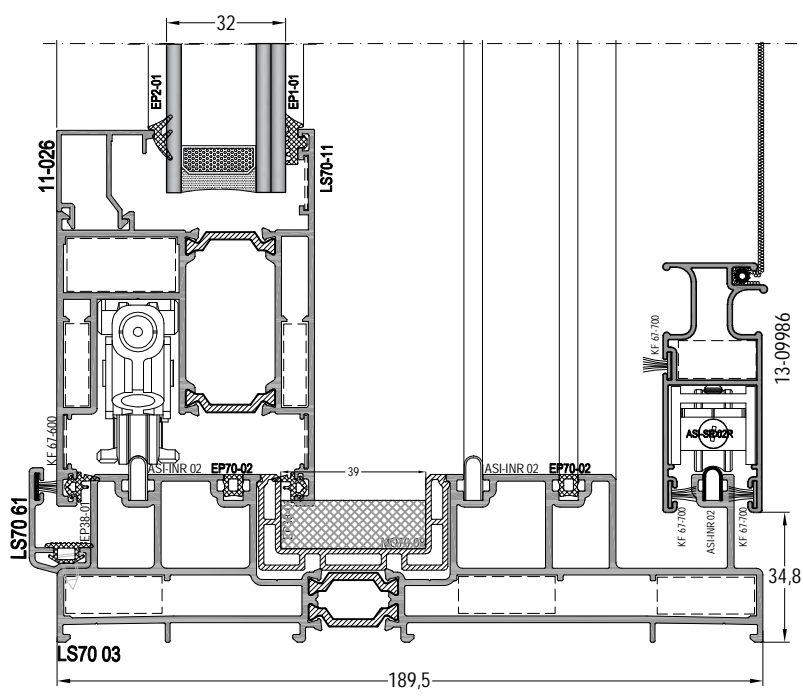
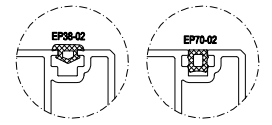

# LS70 - 1,8mm

YALITIMLI KALDIR-SÜR SİSTEMİ  
THERMAL LIFT&SLIDE SYSTEM

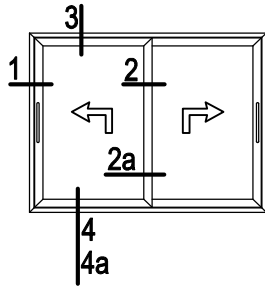

5

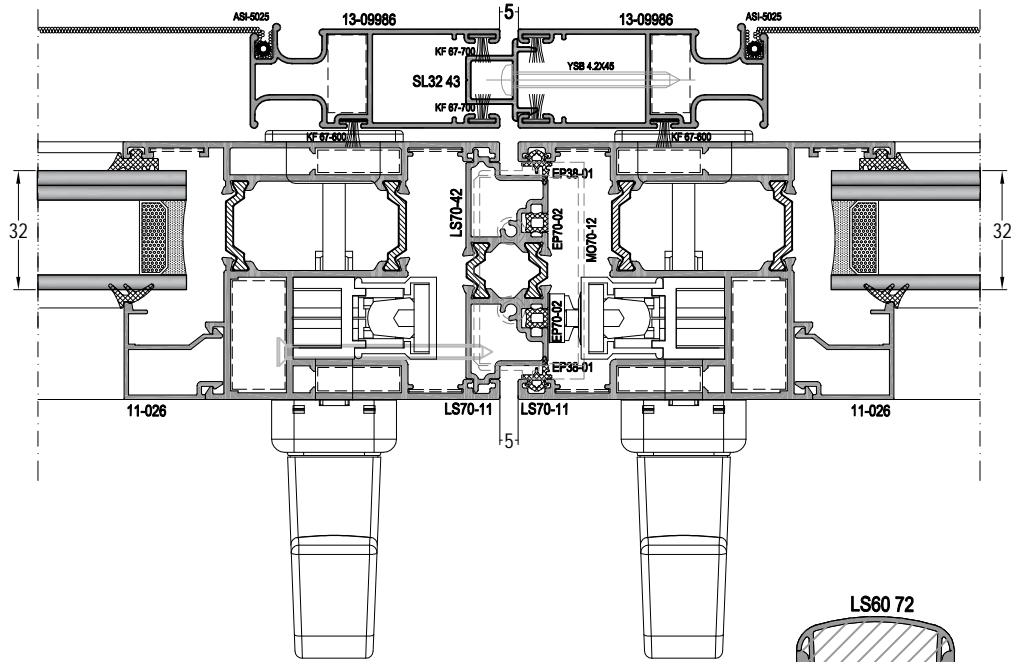
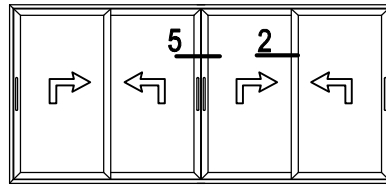

2

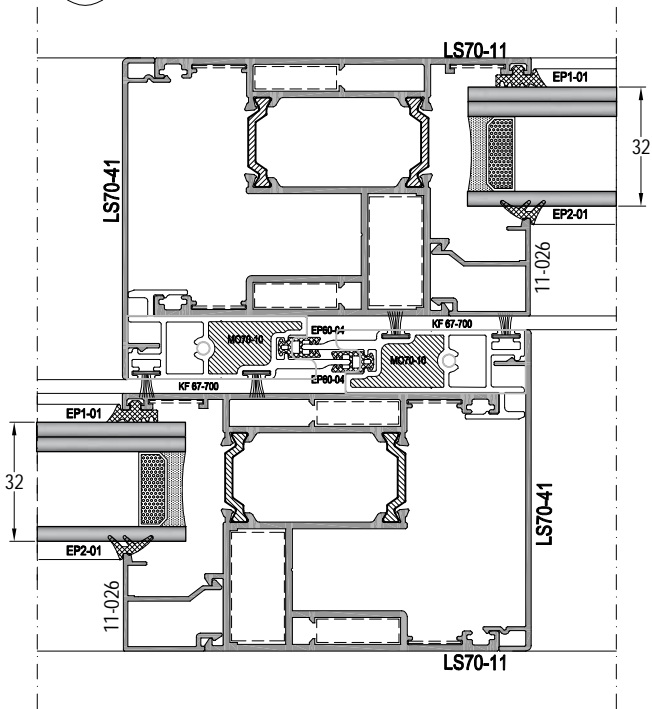

2A

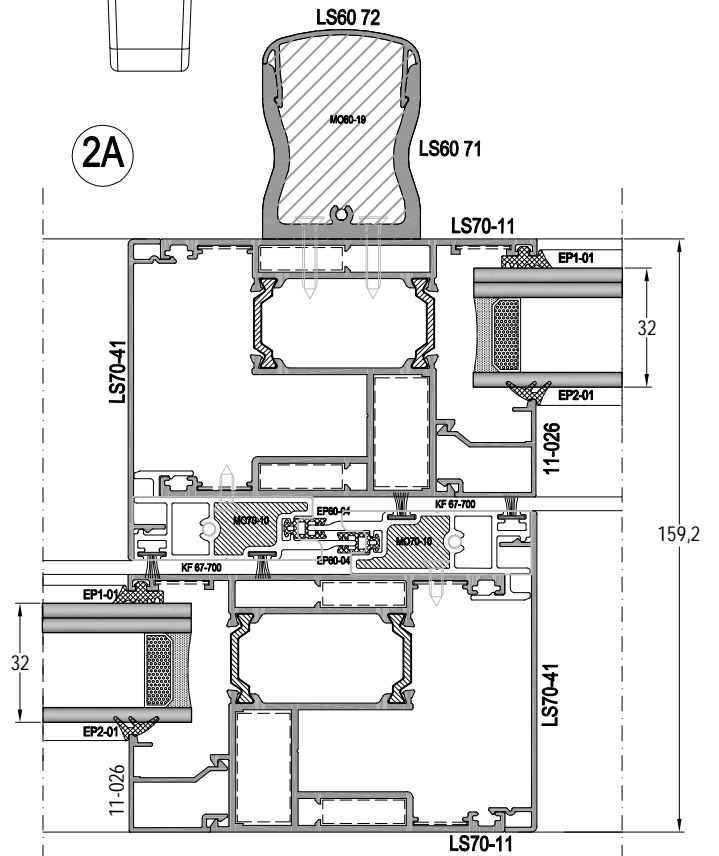

# LS70 - 1,8mm

YALITIMLI KALDIR-SÜR SİSTEM  
THERMAL LIFT&SLIDE SYSTEM

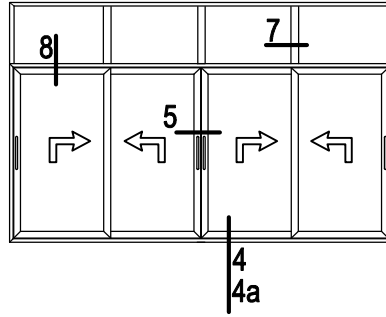
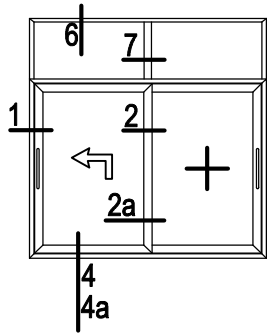

6

7

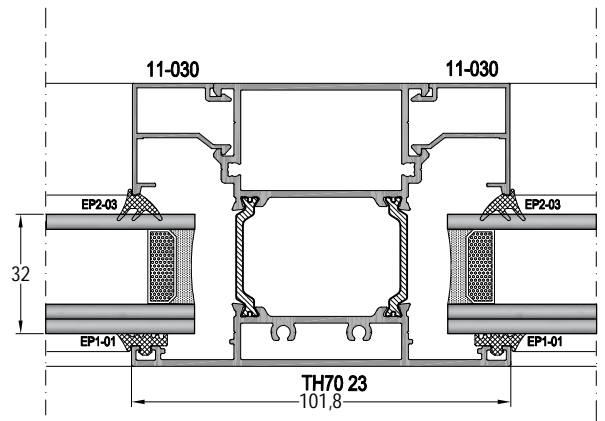
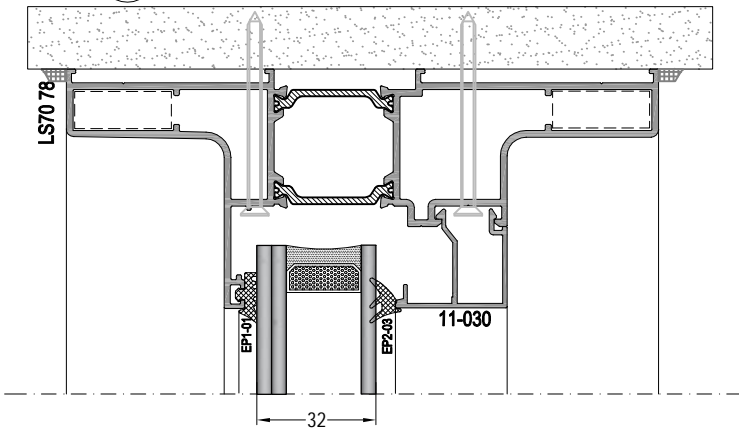

8

4B

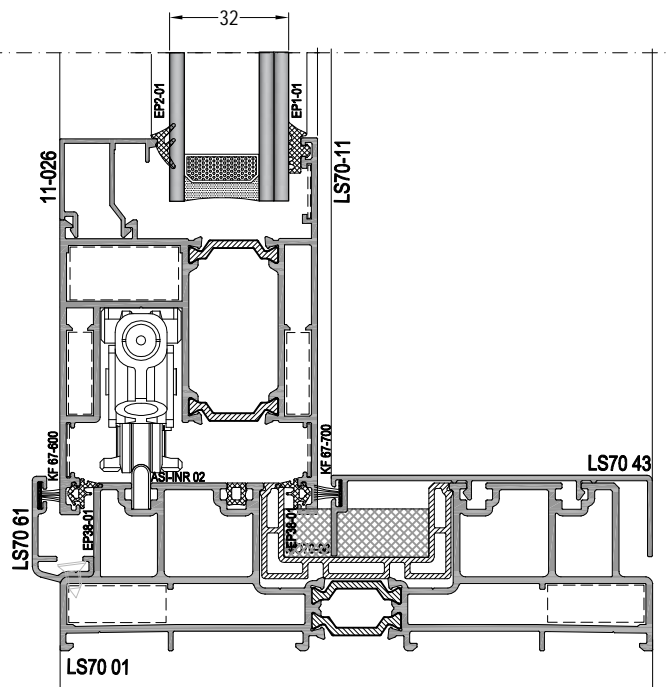
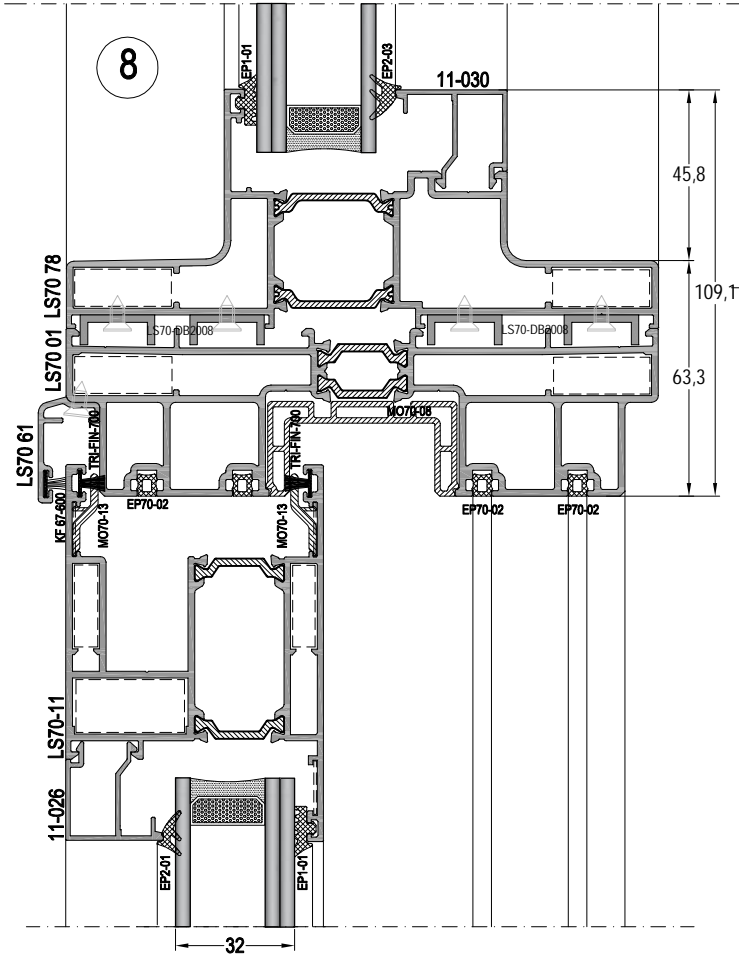



# LS70 - 1,8mm

YALITIMLI KALDIR-SÜR SİSTEM  
THERMAL LIFT&SLIDE SYSTEM

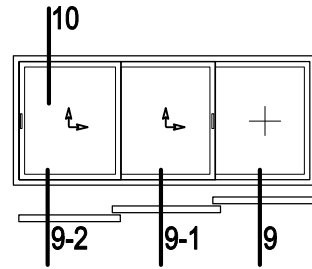
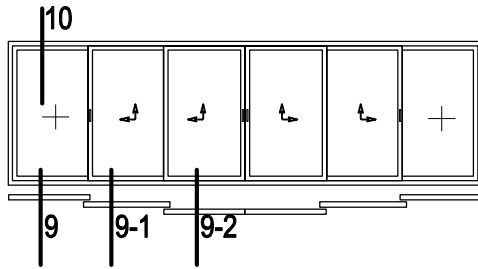

10

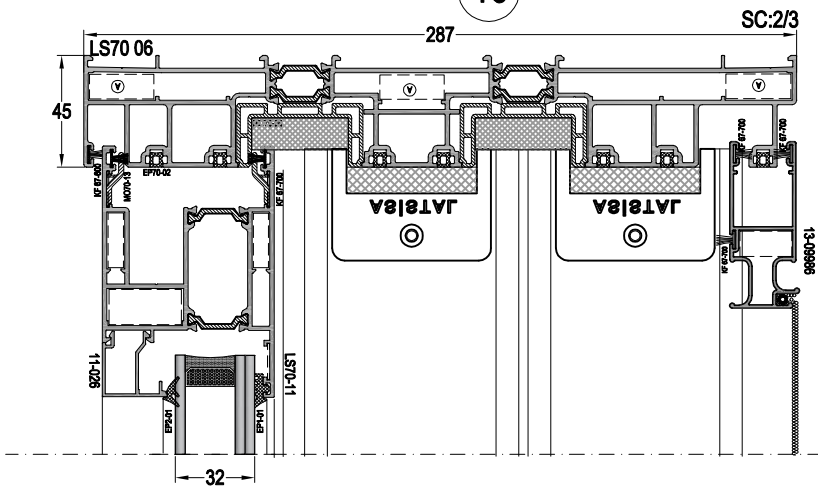

9-2

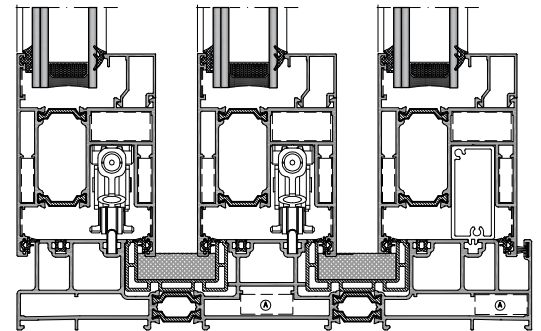

LS70 05

9

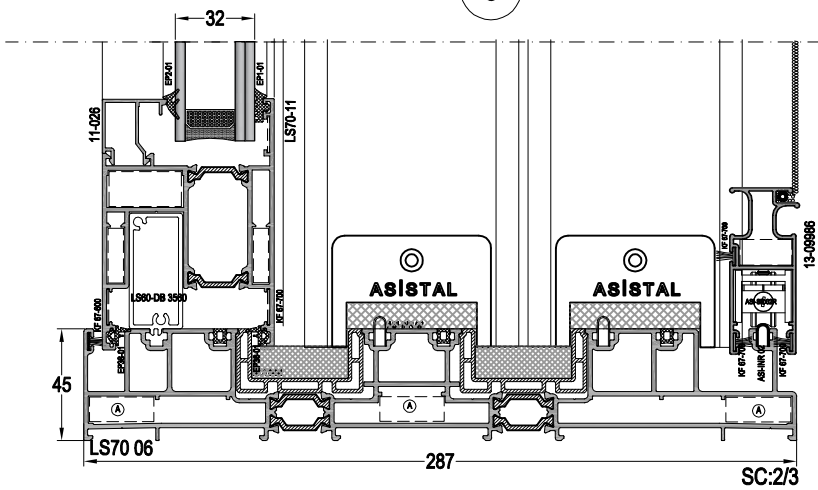

9-1

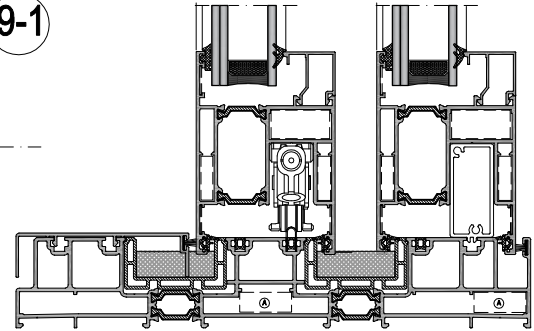

LS70 05

9

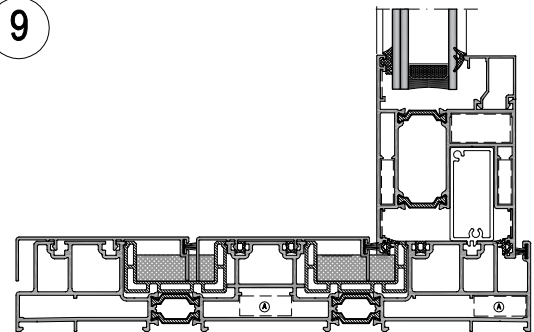

LS70 05

# LS70 - 1,8mm

YALITIMLI KALDIR-SÜR SİSTEM  
THERMAL LIFT&SLIDE SYSTEM

# ASISTAL

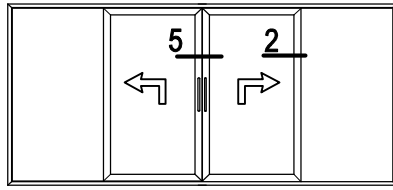
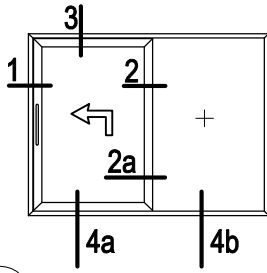

3

1

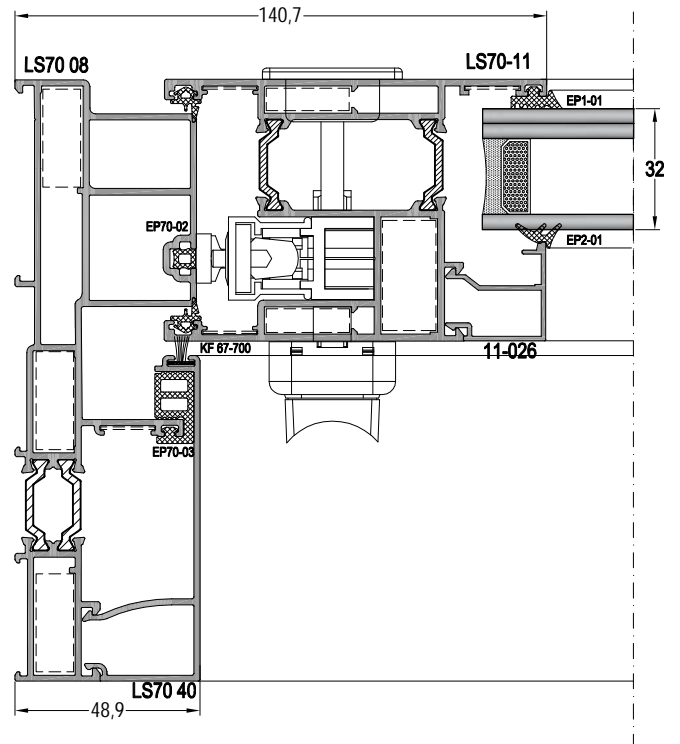
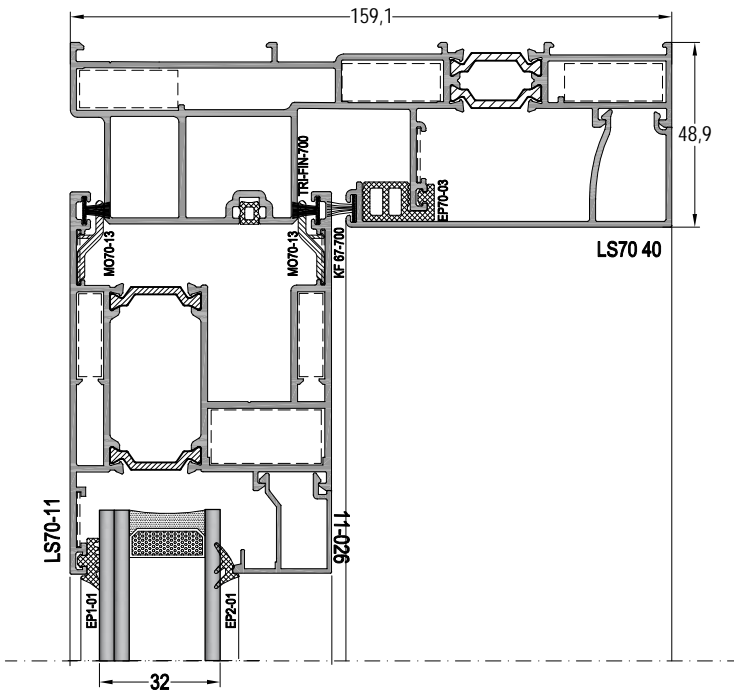

4

4a

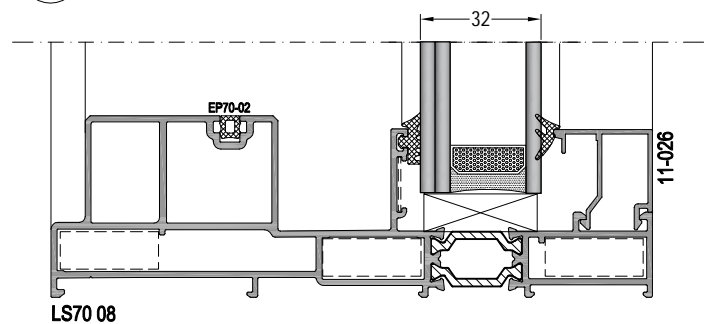
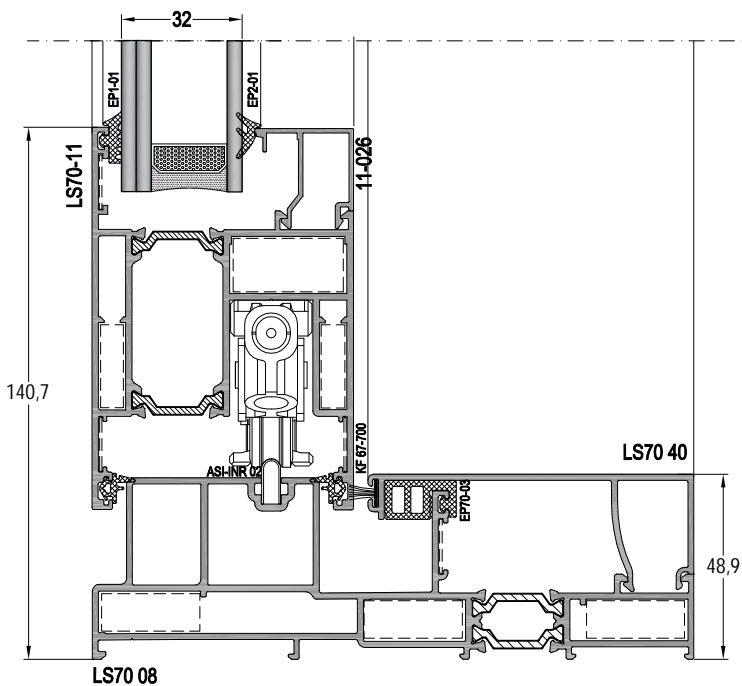

# LS70 - 1,8mm

YALITIMLI KALDIR-SÜR SİSTEM  
THERMAL LIFT&SLIDE SYSTEM

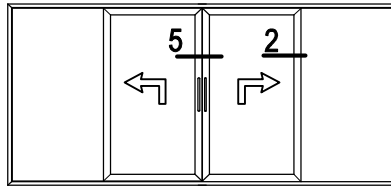
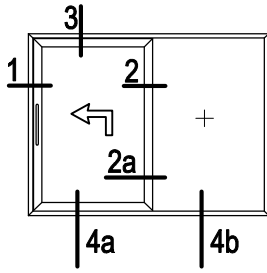

2

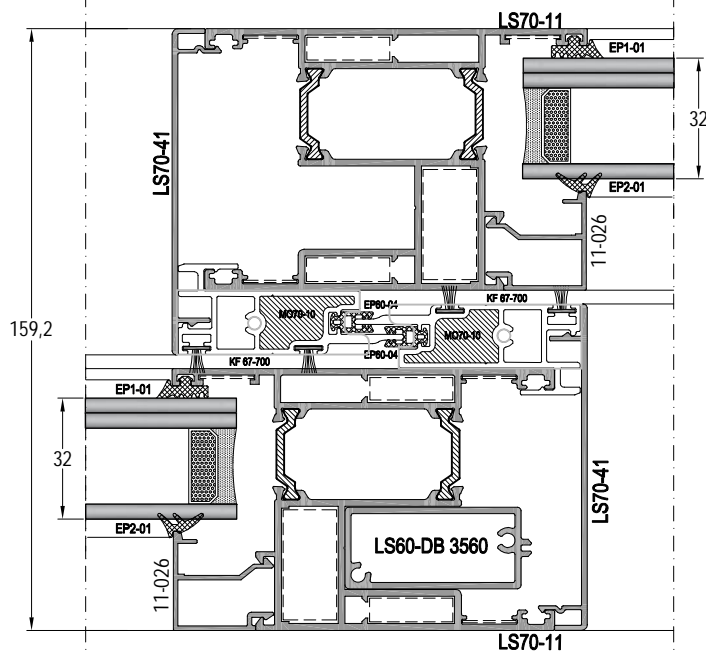

5

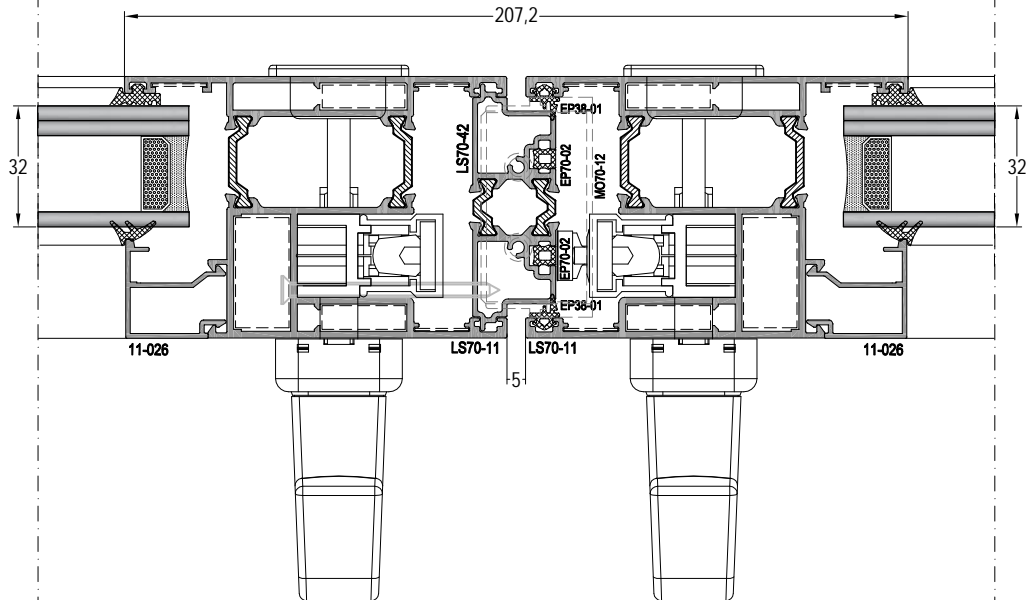

# LS70 - 1,8mm

YALITIMLI KALDIR-SÜR SİSTEM  
THERMAL LIFT&SLIDE SYSTEM

