

OKYANUS[®]

ALÜMİNYUM

“Profilinde Güven Var”
Keep Trust in Our Profile

2022-1 | PROFİL KATALOĞU
PROFILE CATALOGUE

www.okyanusalu.com

HAKKIMIZDA

2004 Yılında sektöre giriş yapan **Okyanus Alüminyum**, kısa sürede sektörde güçlü bir yer edinerek istikrarlı bir büyümeye tempolu yakalamıştır. Üretimine Tekirdağ Muratlı'da 1100 ton 5" , 1540 ton 6" , ve 2000 tonluk 7" presleri ve yine kendi çatısında bulunan boyahane eloksallı kaplama, Kalıphane, ahşap kaplama ünitesi, mekanik işlem merkezi ve daha temiz bir çevre için arıtma tesisi ile hizmet etmeye devam etmekte olan **Okyanus Alüminyum**, bugün sektörün önemli firmaları arasına girmeyi başarmıştır. İstikrarlı ve planlı bir büyüme süreciyle birlikte müşteri beklenti ve taleplerine daha iyi cevap vermektedir. **Okyanus Alüminyum**, 21.000 m² alana kurulu 14.500 m² kapalı alanda, günden güne gelişmekte ve kaliteye verdiği önem dolayısıyla **TSE755:1 , TS EN 15088:2006, ISO 9001:2015, ISO 14001:2015 ,QUALICOAT , QUALANOD ve CE** belgelerini almış bulunmaktadır. Hızlı sevkiyat ve güçlü koordinasyon için merkez ofisini ve deposunu İstanbul'da bulundurmaktadır.

MİSYONUMUZ

Sürekli gelişmeyi, başarıyı amaçlayan bir takım ruhu ile çalışarak, dünya alüminyum sektörüne gelişen teknolojiler paralelinde en kaliteli ürünleri sunmak.

VİZYONUMUZ

- Yurt içinde alüminyum profil sektöründe lider kuruluşlar arasında yer almak,
- Müşteri isteklerinin daima ön planda tutulması,
- Çevreye, doğaya ve topluma saygı,
- İnsan kaynaklarına değer veren, yaratıcılığı destekleyen ve gelişmesine yardımcı olan, açık iletişime dayalı çağdaş yönetim anlayışı,
- Tüm kaynakların verimli kullanılması,
- Müşterilerimiz, tedarikçilerimiz ve çalışanlarımızla bütünlük duygusu,
- Ticari ve sosyal ilişkilerimizde karşılıklı güven, üstün iş ahlakı ve dürüş davranış ilkesinden vazgeçmemek olacaktır.

ABOUT US

Having entered the sector in 2004, **Okyanus Alüminyum** gained a strong position in the sector in a short time and achieved a steady growth pace. Production Line follows as : 1100 tons 5" , 1540 tons 6" , And 2000 tons 7" presses, and a paint shop with anodized coating, mold house, wood coating unit, mechanical process center and treatment unit for cleaner environment under its own roof in Tekirdağ Muratlı. **Okyanus Alüminyum** continues to be among the important companies in the sector today. We respond better to customer expectations and demands with a stable and planned growth process. Due to the importance of quality day by day, **Okyanus Alüminyum** has received **TSE755:1 , TS EN 15088:2006, ISO 9001:2015, ISO 14001:2015 ,QUALICOAT , QUALANOD ve CE** certificates. Our head Office and warehouse in Istanbul for fast shipment and strong coordination.

OUR MISSION

To offer best quality products align with developing Technologies to world's aluminum sector by a team spirit that is aimed at continuous developing and achievement.

OUR VISION

- To gain place among the leaders of aluminium profiles sector in Turkey,
- To put the customer demands and expectations always forefront,
- To appropriate the environment, nature and society,
- A management system that cares about human resource, supports of and assists the creativeness, and is based on open communication,
- Sustainable management of all sources,
- Becoming one with our customers, suppliers and employees,
- To maintain mutual trust in our commercial and social activities, to keep eminent work ethic standards.

İÇİNDEKİLER / INDEX

STANDART PROFİLLER / Standard Profiles	3 - 10
ALDOKS SERİSİ / Aldox Series	11 - 16
C-60 SERİSİ / C-60 Series	17 - 22
55' LİK YALITIMSIZ SERİ / 55'lik Non-Insulated Series	23 - 29
FC-50 CEPHE SİSTEMLERİ / FC-50 Facade Systems	30 - 41
KÜPEŞTE PROFİLLERİ / Handrail Profiles	42 - 53
CAM BALKON PROFİLLERİ / Glass Balcony Profiles	54 - 70
ISI CAMLI SÜRME PROFİLLERİ / Double Glased Slide	71 - 82
GİYOTİN SİSTEMİ / Guillotine Systems	83 - 86
FC-160 KIŞ BAHÇESİ SİSTEMİ / FC-160 Winter Garden Systems	87 - 94
Çit Sistemleri / Alufence Systems	95 - 102
SİNEKLİK PROFİLLERİ / Flyscreen Profiles	103 - 105
KEPENK & PANJUR PROFİLLERİ / Blind & Shutter Profiles	106 - 111
OFİS BÖLME PROFİLLERİ / Office Partitions Profiles	112 - 114
TENTE PROFİLLERİ / Awning Profiles	115 - 120
DUŞAKABİN PROFİLLERİ / Shower Cabin Profiles	121 - 127
MOBİLYA PROFİLLERİ / Furniture Profiles	128 - 132
KAPI & PENCERE AKSESUAR PROFİLLERİ / Doors Windows Accessory Profiles	133 - 139
KÜPEŞTE AKSESUARLARI PROFİLLERİ / Handrail Accessory Profiles	133 - 139
OVAL SERİ PROFİLLERİ / Oval Series Profiles	140 - 151
LİBYA KAPI & PENCERE SİSTEMLERİ / Libya Door & Windows Systems	152 - 164
SÜPÜRGELİK PROFİLLERİ / Florr Profiles	165 - 167
DİLATASYON PROFİLLERİ / Dilatation Profiles	165 - 167

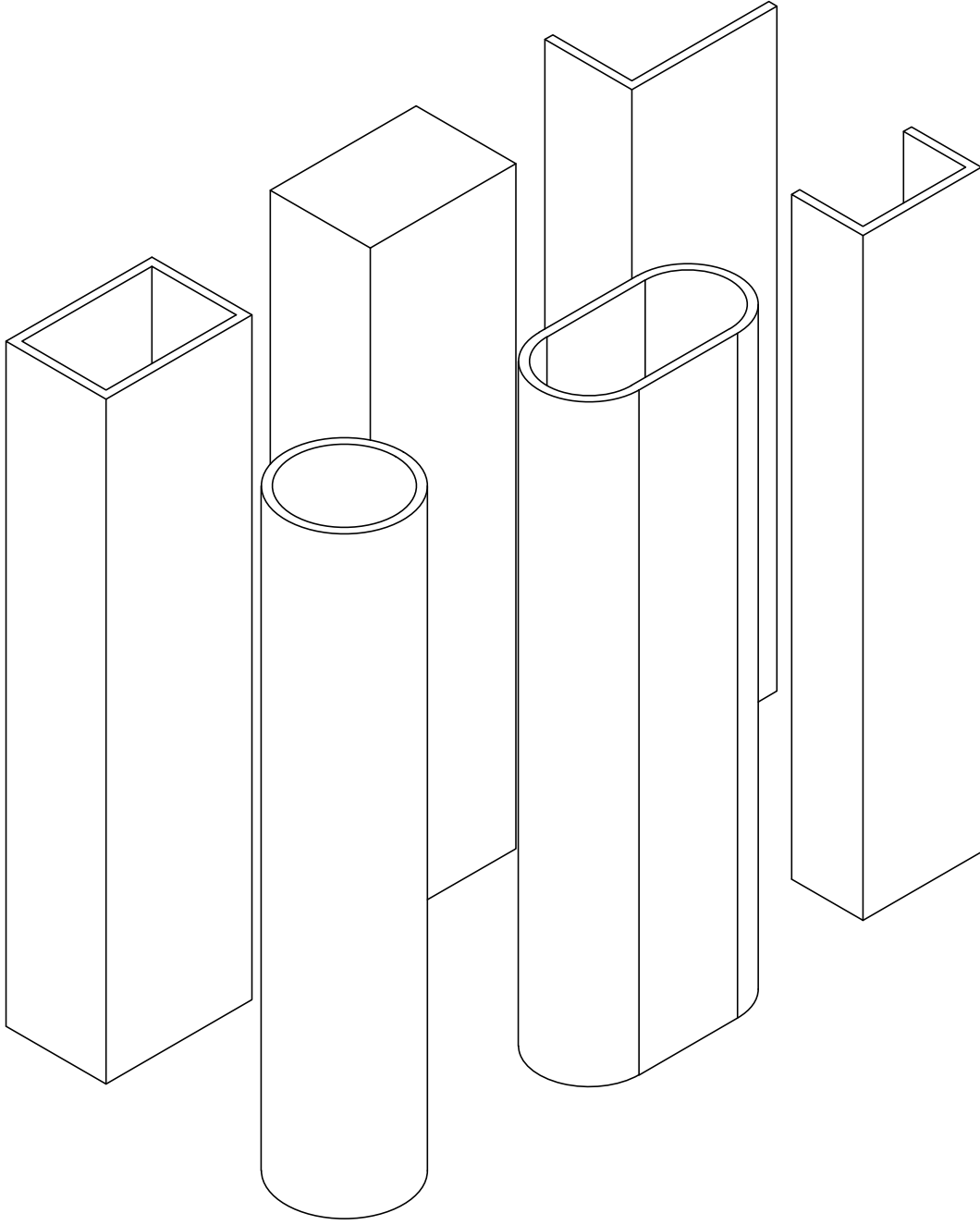

STANDART PROFİLLER / Standard Profiles

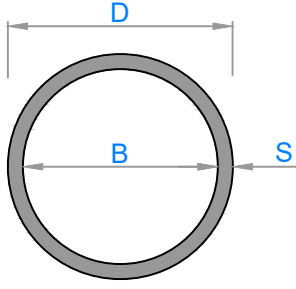

BORU PROFİLLERİ / Round Tubes

KALIP NO	D mm (dış çap)	B mm (iç çap)	S mm	GRAMAJ
1000	7	5	1	0,052
1397	8	6	1	0,060
1215	9	7	1	0,071
1005	10	8	1	0,076
4325	10,1	5,3	2,4	0,157
1358	11	9	1	0,087
1009	12	9,95	1,03	0,096
2123	12	10	1	0,094
1371	12	10,2	0,9	0,085
2364	12	9,9	1,05	0,101
2133	12,1	10,25	0,925	0,090
2125	12,5	9	1,75	0,163
1008	13	11	1	0,103
3051	13	10	1,5	0,147
1522	13,8	11,9	0,95	0,106
1800	13,8	10	1,9	0,196
5661	14	12	1	0,110
1954	14	10	2	0,206
4182	15	13	1	0,120
1637	15	9	3	0,309
2749	15,32	11	2,15	0,244
1627	16	14	1	0,131
3363	16	13,6	1,2	0,149
2674	16	13	1,5	0,187
1484	16	12	2	0,238
1356	16	10	3	0,334
1207	19,5	17	1,25	0,196
1533	17,9	16,2	0,85	0,495
1626	18,5	16,5	1	0,150
1666	18,5	13,5	2,5	0,339
1001	19	17	1	0,155
1654	19	16,6	1,2	0,185
2140	19	16,4	1,3	0,196
4364	19,95	5,2	7,37	0,789
1342	20	18	1	0,163
5318	20	17	1,5	0,236
1010	20	16	2	0,307
4780	20	9	5,5	0,679

KALIP NO	D mm (dış çap)	B mm (iç çap)	S mm	GRAMAJ
1570	21,3	19,5	0,9	0,158
1652	22	20,4	0,8	0,147
1655	22	19,4	1,3	0,229
1653	22	19	1,5	0,263
1012	22	12	5	0,724
1572	22,5	20	1,25	0,228
1653	22	19	1,5	0,262
3331	23	21	1	0,187
1824	23	20	1,5	0,277
2168	23,5	21,5	1	0,193
5170	24	22,4	0,8	0,158
2713	24	22,2	0,90	0,177
5069	24	18	3	0,536
4815	24,8	22,2	1,3	0,260
2615	24,8	22	1,4	0,279
1757	25	23	1	0,206
3782	25	22,2	1,4	0,282
1014	25	21	2	0,393
2807	25	20	2,5	0,480
1890	29	26,8	1,1	0,263
1571	29,5	25	2,25	0,520
3287	30	27	1,5	0,360
1006	30	26	2	0,477
1168	30	24	3	0,692
1013	32	30	1	0,266
4699	32	29	1,5	0,389
1469	33	29	2	0,528
4148	33,6	30,1	1,75	0,474
5622	33,7	27,7	3	0,784
4432	34	18,5	7,75	1,732
4504	35	32	1,5	0,414
1446	35	31	2	0,564
1591	35	30	2,5	0,693
1016	35	29	3	0,819
4779	35	13,25	10,87	2,233
2643	35,15	33	1,07	0,315
4181	38	34	2	0,613
1280	40	38	1	0,334

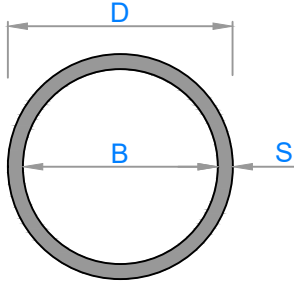

BORU PROFİLLERİ / Round Tubes

KALIP NO	D mm (dış çap)	B mm (iç çap)	S mm	GRAMAJ
1003	40	37,5	1,25	0,412
1635	40	37	1,5	0,494
2190	40	36	2	0,648
1602	40	30	5	1,491
2198	40	21	9,5	2,469
5621	42	36	3	0,996
3221	42	34	4	1,294
5055	44,4	25,4	9,5	2,832
1649	45	42	1,5	0,555
1670	45	41	2	0,731
1018	48	44	2	0,784
1017	50	48	1	0,419
4069	50	47,6	1,2	0,498
3533	50	47,2	1,4	0,580
1019	50	47	1,5	0,621
3534	50	46,6	1,7	0,700
3252	50	46,4	1,8	0,737
1007	50	46	2	0,819
1169	50	45	2,5	1,011
1020	50	44	3	1,201
1002	50	40	5	1,915
5054	50,8	31,8	9,5	3,347
1891	51	48,2	1,4	0,594
2194	53	41	6	2,402
3757	54	50	2	0,886
3957	53,8	51,1	1,3	0,603
2134	55	50	2,5	1,120
1799	55	41	7	2,860
1430	60	55	2,5	1,224
1567	60	57	1,5	0,747
5548	60	50,5	4,75	2,234
1481	64	54	5	2,511
2081	65	61	2	1,074
4529	70	66	2	1,158
4635	70	65	2,5	1,436
1004	70	64	3	1,713
3494	75	14	30,5	11,555
2553	75	67	4	2,417
4882	76	70	3	1,864

KALIP NO	D mm (dış çap)	B mm (iç çap)	S mm	GRAMAJ
5519	80	77	1,5	1,005
1639	80	75	2,5	1,651
1625	80	74	3	1,968
1011	81,5	73,5	4	2,639
2424	90	76	7	4,949
5291	100	96	2	1,669
1812	100	86	7	5,542
1537	101,3	98,3	1,5	1,276
3202	110	98	6	5,315
5292	125	121	2	2,094

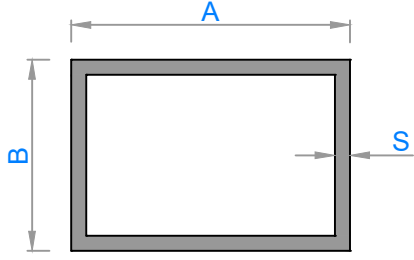

DİKDÖRTGEN KUTU PROFİLLERİ

Rectangular Tubes

KALIP NO	A mm	B mm	S mm	GRAMAJ
4133	17	11	1,5	0,204
1033	18	12	1	0,152
1030	20	10	1,1	0,169
1710	20	15	2	0,337
1517	22,2	10	1,2	0,196
2230	23,2	7,6	0,75	0,120
1032	25	17	1	0,216
4827	25	17	1,5	0,317
1886	25	15	2	0,391
1776	27	22	1,35	0,341
1483	30	15	1	0,236
1028	30	20	1,2	0,308
1464	30	20	1,5	0,382
4833	30	20	2	0,498
1767	39,6	19,6	0,9	0,282
1036	40	30	1	0,369
1031	40	20	1,2	0,374
5201	40	20	1,5	0,463
5080	40	20	2	0,607
4167	40	20	3	0,878
4889	44	27	1	0,374
5431	46	26	1,5	0,561
4499	49,2	20,1	1,5	0,539
5340	50	35	2	0,878
1035	50	40	0,85	0,407
4131	50	10	1,2	0,375
5623	60	25	2,0	0,880
5624	60	25	3,0	1,285
1603	60	40	1,5	0,789
3344	65	25	1,2	0,570
2568	65	28	1	0,490
1029	75	32	1,1	0,627
5267	75	32	1,5	0,845
4459	80	40	1,4	0,889
2755	80	50	4	2,645
1034	95	50	1,5	1,155
2321	100	20	2	1,258
4568	100	68	2	1,778

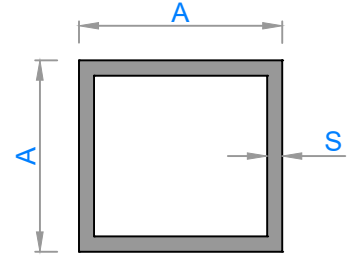

KUTU PROFİLLERİ / Square Tubes

KALIP NO	A mm	S mm	GRAMAJ
2143	10	1	0,098
3766	14	1,5	0,204
2702	15	1	0,152
1021	20	1	0,206
2875	20,5	1,7	0,346
1022	25	1,3	0,337
1027	25	2	0,499
1024	30	1,2	0,374
1208	30	1,5	0,464
1026	40	1	0,423
2237	40	1,5	0,626
1941	40	3	1,204
1662	45	2	0,933
4548	46,5	3	1,415
1023	50	2	1,041
1025	50	3	1,528
3948	55	1,3	0,757
1951	60	1,5	0,952
5295	80	2	1,691
4126	100	2	2,124
4188	100	4	4,162

DİKDÖRTGEN KUTU PROFİLLERİ

Rectangular Tubes

KALIP NO	A mm	B mm	S mm	GRAMAJ
4725	109	80	3	2,975
5616	120	60	2	1,907
4567	124,5	98,5	2,2	2,606



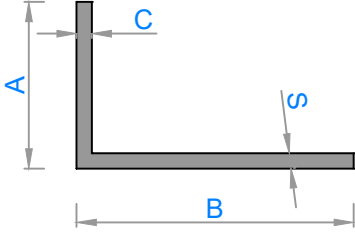

L KÖŞEBENT PROFİLLERİ

Angles (Unequal)

KALIP NO	A mm	B mm	S mm	C mm	GRAMAJ
4925	7	40	2	2	0,244
4926	9	40	2	2	0,251
2437	8	18	1	1	0,068
4145	10	15	1,4	1,4	0,089
1060	10	20	1,2	1,2	0,95
4146	15	20	1,4	1,4	0,127
1059	15	30	1,2	1,2	0,143
1196	15	30	1,5	1,5	0,179
3214	20	25	2	2	0,233
4528	20	30	3	3	0,382
5173	20	34	1,5	1,5	0,212
1266	20	40	1,2	1,2	0,193
1061	20	40	1,5	1,5	0,239
2174	20	50	1,2	1,2	0,225
1638	20	50	3	3	0,545
1062	20	60	1,2	1,2	0,258
3213	20	60	2	2	0,422
4029	20	80	1,45	1,45	0,387
4030	20	100	1,45	1,45	0,465
5413	20	120	1,5	1,5	0,563
4683	30	55	5	5	1,084
3215	30	60	3	3	0,707
3273	40	60	1,5	1,5	0,400
2226	40	75	5	5	1,491
2227	40	80	5	5	1,559
5026	45	62	4	4	1,116
2771	50	100	3	3	1,196

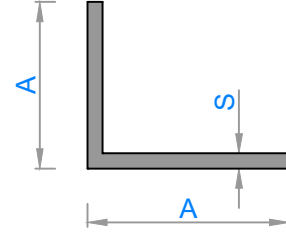

KÖŞEBENT PROFİLLERİ

Equal Angles

KALIP NO	A mm	S mm	GRAMAJ
1068	10	1,2	0,063
1063	15	1,2	0,095
1066	20	1,2	0,128
1203	20	2	0,206
2511	25	1	0,136
1064	25	1,2	0,159
2512	30	1	0,160
1065	30	1,2	0,193
1217	30	2	0,315
3222	30	3	0,463
1249	40	1	0,215
2833	40	1,5	0,320
4834	40	2	0,422
1664	40	3	0,627
1067	40	4	0,824
1663	60	3	0,949
1857	70	5	1,833

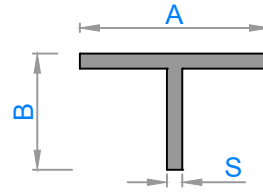

T PROFİLLERİ

T Profiles

KALIP NO	A mm	B mm	S mm	GRAMAJ
1037	25	25	1,2	0,158
1257	25	25	3	0,382
1038	30	30	1,5	0,239
1961	30	30	3	0,464
3274	50	50	2	0,528

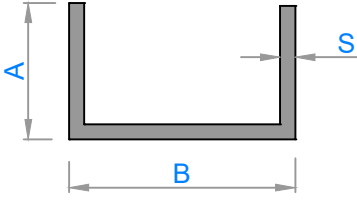

U PROFİLLERİ

U Profiles

KALIP NO	A mm	B mm	S mm	GRAMAJ
2300	12,7	12,7	0,95	0,095
1252	15	17	0,9	0,111
1058	16	17,5	1	0,130
1251	17	17	1	0,133
1681	18,2	12,2	1	0,128
1057	20	19	1,1	0,170
1235	20	12,6	1,1	0,152
4480	20	13,6	1,7	0,231
1896	20	20	1	0,158
3449	20	20	2	0,304
2903	20	36	3,5	0,655
2172	20,5	21,3	1,25	0,204
2865	22	15	1,5	0,228
4479	25	13,6	1,7	0,277
2251	25	16	2	0,339
1695	25	26	1	0,201
5078	26,5	25	1,2	0,245
1234	28	14	1,2	0,220
1090	30	16	1,8	0,352
3448	30	20	2	0,412
3063	30	30	2	0,466
1842	35	45	2	0,602
2756	40	30	2	0,575
4835	40	40	2	0,628
1841	40	50	2	0,683
4836	40	80	2	0,845
4218	48	50,4	3	1,141
2754	50	100	5	2,575
2954	30	56	2	0,607
3612	64	100	6,4	3,732

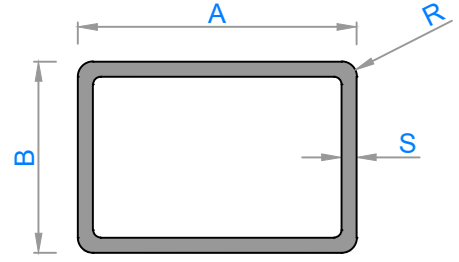

RADIÜSLÜ KUTU PROFİLLERİ

Radius Rectangular Tubes

KALIP NO	A mm	B mm	S mm	R mm	GRAMAJ
2419	16,45	7,2	1	0,5	0,120
1903	17,8	11,8	0,9	1,9	0,131
3115	20	7	1,2	0,5	0,160
3048	22	22	1,5	3	0,317
5097	22,5	22,5	0,9	3	0,200
5615	24	14	1,2	7	0,196
5098	26	26	0,9	3	0,234
1811	30,5	18,5	1,3	3	0,312
2056	33	20	0,9	3	0,242
2079	33	20	1,2	3	0,318
1700	40	20	1,2	2,9	0,364
5611	50	30	1,5	1	0,624
1384	60	25	1,2	5,5	0,513
1056	60,4	26,75	3,3	2,75	1,422
4582	95	95	2	11	1,923

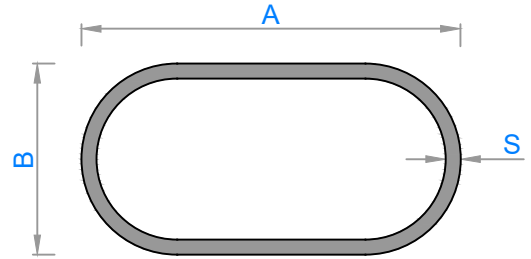

OVAL KUTU PROFİLLERİ

Flat Tubes

KALIP NO	A mm	B mm	S mm	GRAMAJ
2308	14,9	6,9	0,95	0,090
5596	18,4	18,4	0,95	0,155
1054	26	15	1,5	0,261
1826	26	10	1,25	0,204
2142	30	15	1,1	0,223
5597	30	17,6	0,9	0,192
5225	30	18	1,2	0,250
1250	30,5	10,5	1,25	0,236
1055	80	26	1,5	0,750

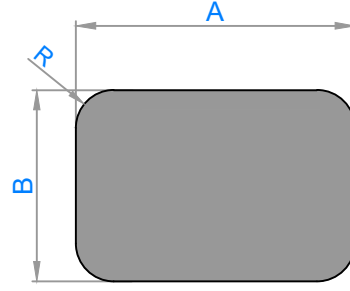
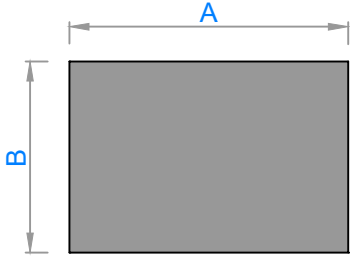

DİKDÖRTGEN LAMA PROFİLLERİ

Flat Bars

KALIP NO	A mm	B mm	GRAMAJ
2353	8,2	1,6	0,035
1668	10	3	0,082
2837	12	8	0,260
3594	14	12	0,455
1665	15	4	0,163
1892	15	5	0,201
2690	15,1	8,1	0,331
3585	18,5	10	0,501
4150	20	2	0,110
1660	20	3	0,163
4156	20	8	0,434
4822	20	10	0,542
5421	22	2	0,125
2262	23	11	0,686
3584	24	5	0,325
2462	25	8	0,542
1633	25	10	0,678
3875	30	3	0,244
1042	30	5	0,407
2461	30	7	0,570
1047	30	16	1,301
1046	30	20	1,626
1636	31,5	4	0,342
2835	40	1,5	0,163
5585	40	4	0,432
5314	40	7	0,759
4960	45	10	1,219
2636	50	3	0,406
1041	50	5	0,678
1865	50	6	0,795
1634	50	9	1,220
1045	50	10	1,355
1992	60	10	1,626
5684	80	5	1,084
1043	80	10	2,168
1044	100	10	2,710
3201	106	12	3,448

RAİDUSLU DİKDÖRTGEN LAMA PROFİLLERİ

Radius Flat Bars

KALIP NO	A mm	B mm	GRAMAJ	RADIUS
1728	15,5	4,5	0,179	2,25
2311	25	2,8	0,187	1,4
1659	40	10	1,028	5
5070	118	10	3,195	1

DİKDÖRTGEN LAMA PROFİLLERİ

Flat Bars

KALIP NO	A mm	B mm	GRAMAJ
1608	133	2	0,721
1656	150	15	6,098
2550	200	17,5	9,485
2446	200	30	16,251



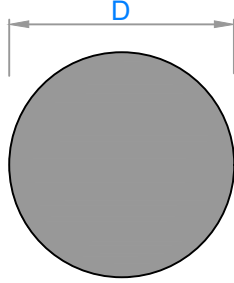

DOLU ÇUBUK PROFİLLERİ

Round Bars

KALIP NO	D mm	GRAMAJ
1052	3	0,022
1536	5	0,055
1367	6	0,079
1628	7,8	0,130
2377	10	0,215
1051	12	0,306
1651	16	0,545
2708	18	0,692
2543	19,95	0,846
1050	22	1,030
1049	25	1,331
4453	29	1,790
4947	30	1,915
1600	32	2,182
1048	35	2,610
1601	38	3,076
2187	40	3,407
2130	41	3,578
1354	44	4,120
4948	45	4,310
2186	50	5,323
1650	55	6,440
4475	60	7,662
4949	65	8,992
2319	70	10,431
1053	80	13,620

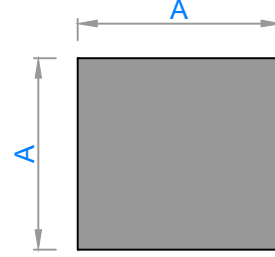

KARE LAMA PROFİLLERİ

Square Bars

KALIP NO	A mm	GRAMAJ
1874	5	0,068
2692	10	0,271
5315	14	0,531
5804	25	1,695
2565	35	3,320

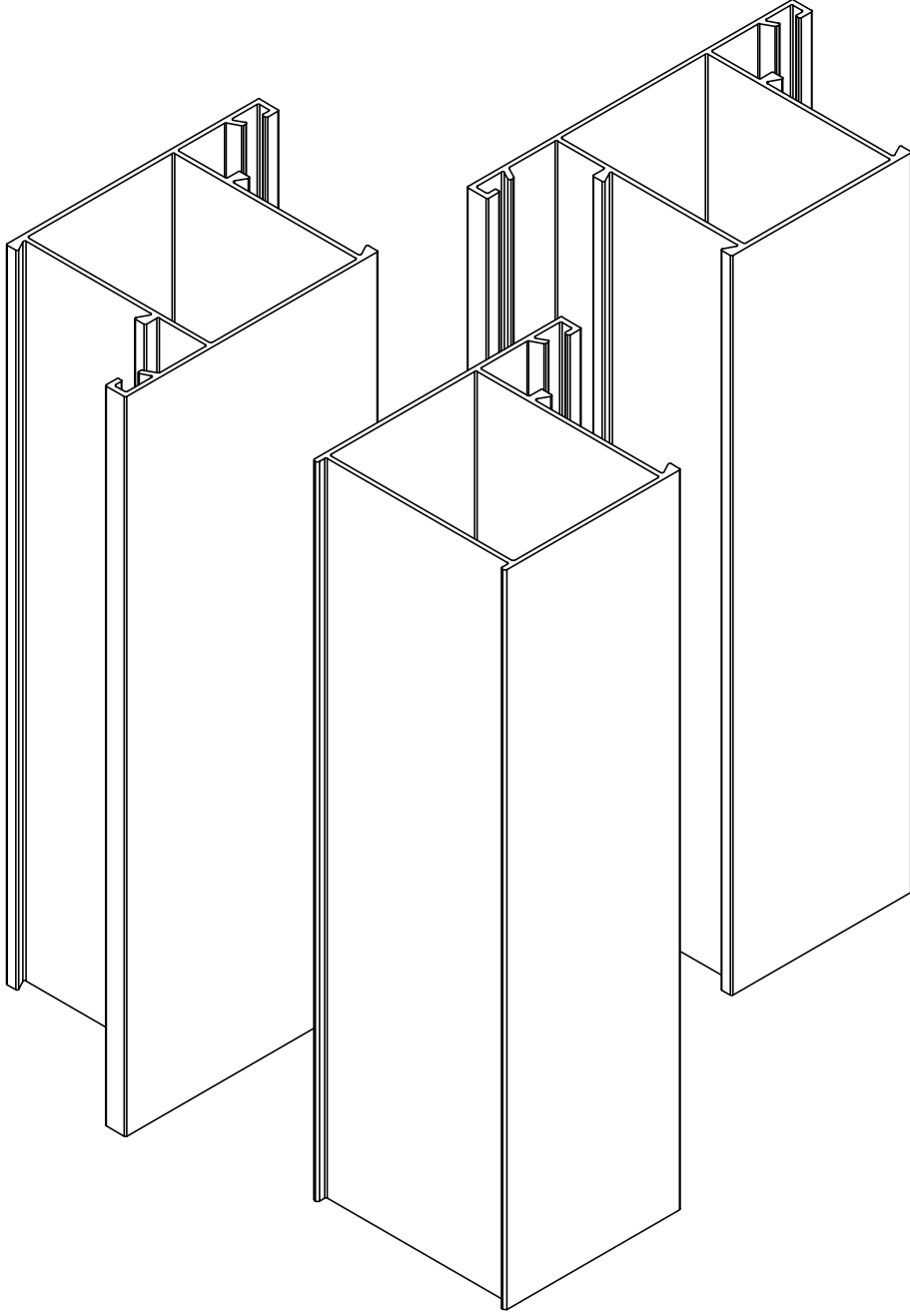

ALDOKS SERİSİ / Aldox Series

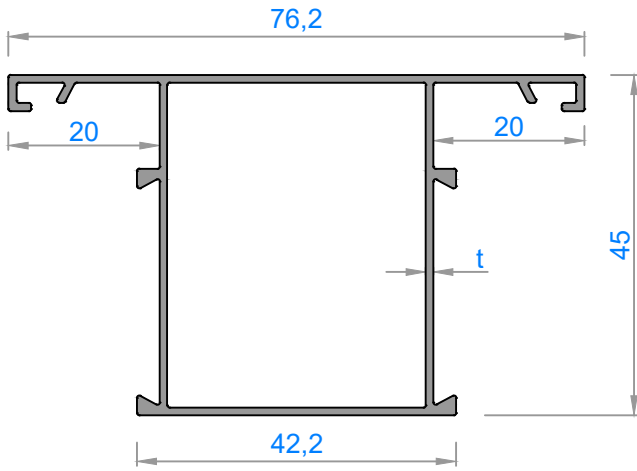

t=1 1077 - 0,655 kg/m
t=1.5 3617 - 0,891 kg/m
t=2 1296 - 1,168 kg/m

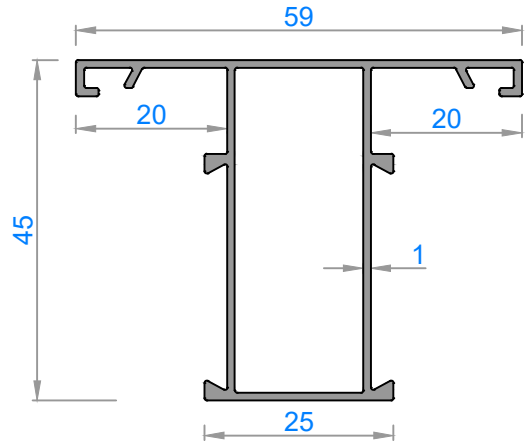

1080 - 0,564 kg/m

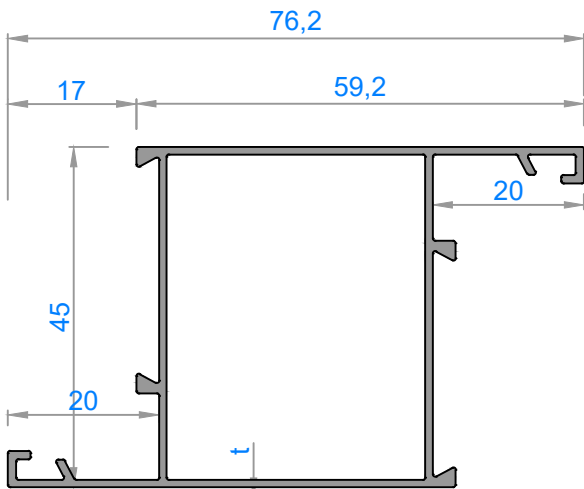

t=1 1076 - 0,655 kg/m
t=1.5 3616 - 0,891 kg/m
t=2 1298 - 1,168 kg/m

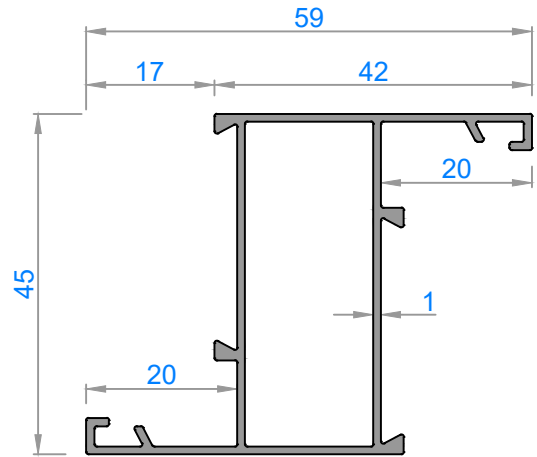

1079 - 0,563 kg/m

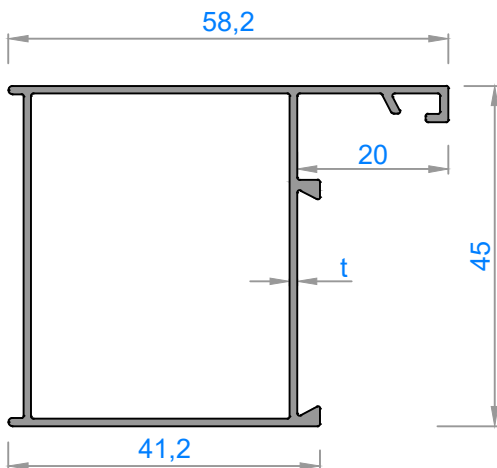

t=1 1075 - 0,555 kg/m
t=1.5 3618 - 0,788 kg/m
t=2 1297 - 1,025 kg/m

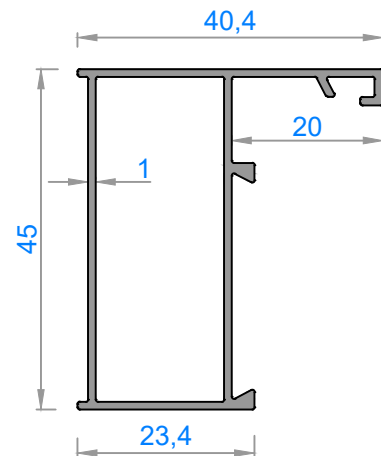

1078 - 0,458 kg/m

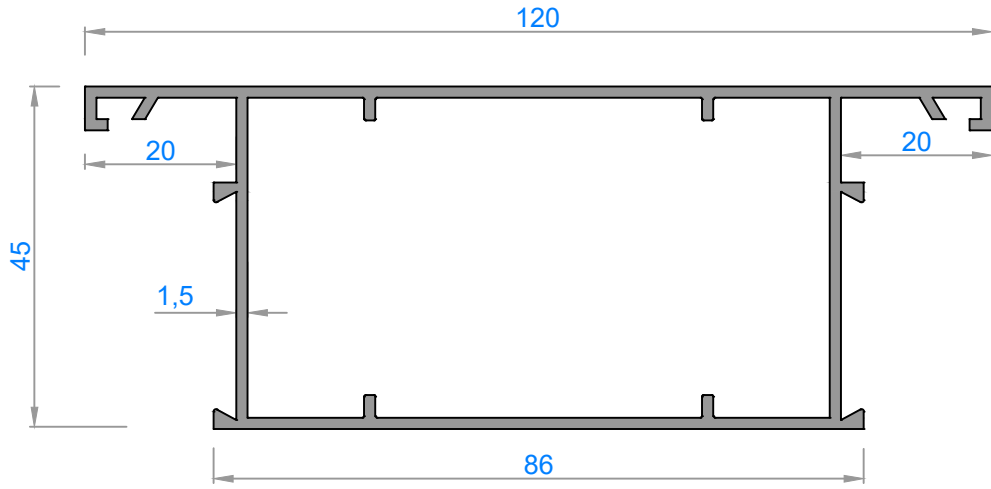

1103 - 1,343 kg/m

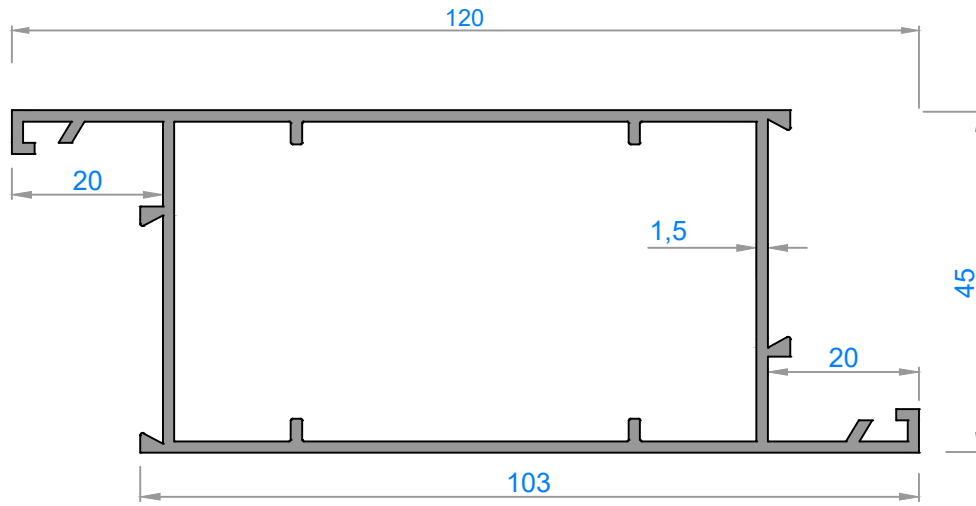

1102 - 1,343 kg/m

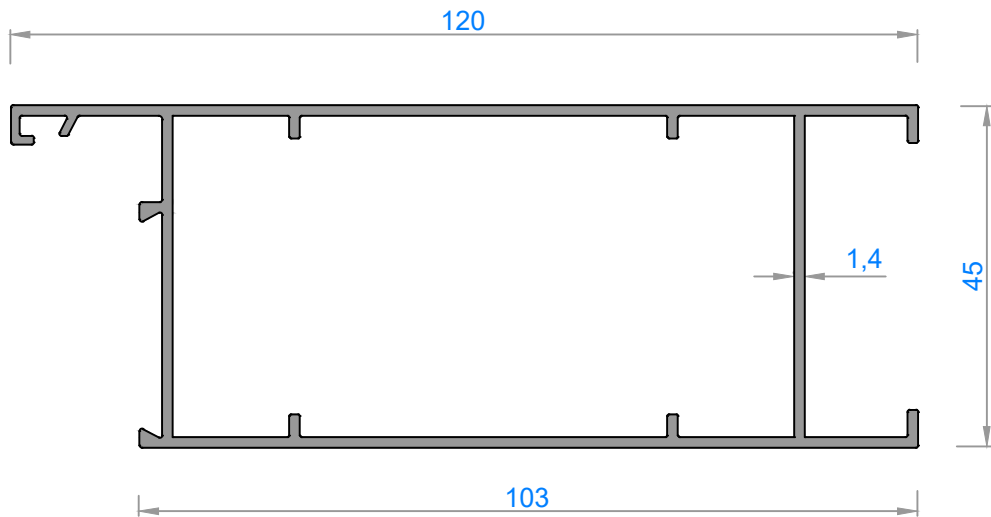

1101 - 1,288 kg/m

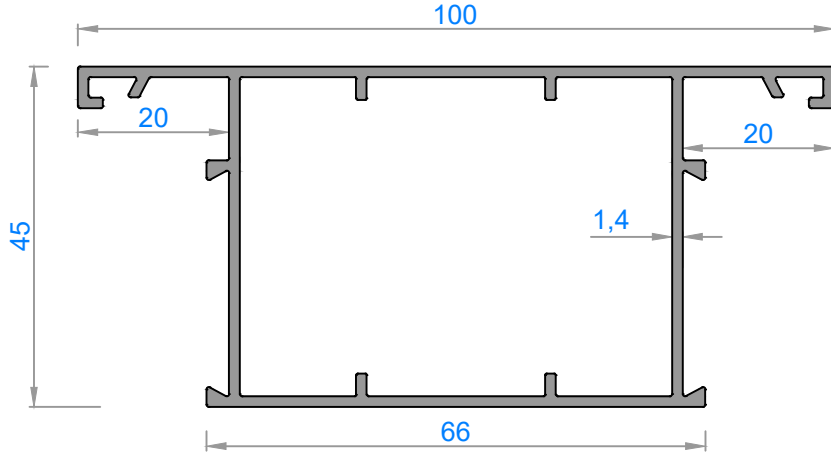

* 1241 - 1,106 kg/m

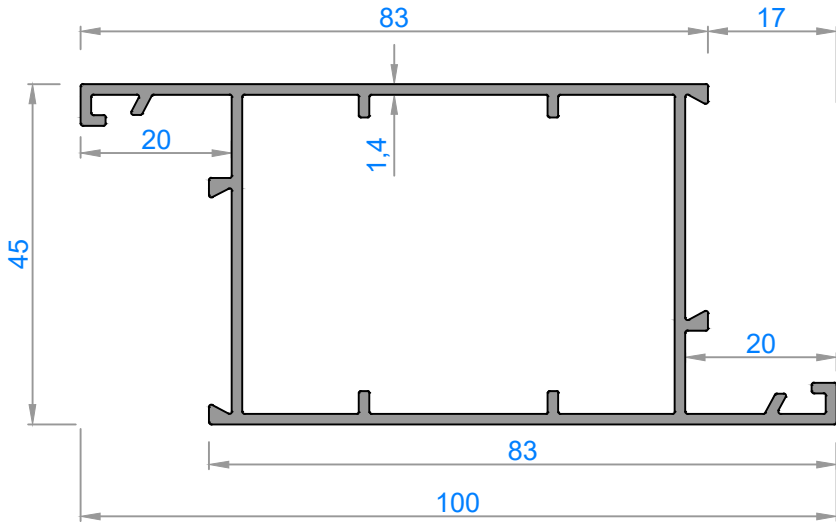

* 1240 - 1,106 kg/m

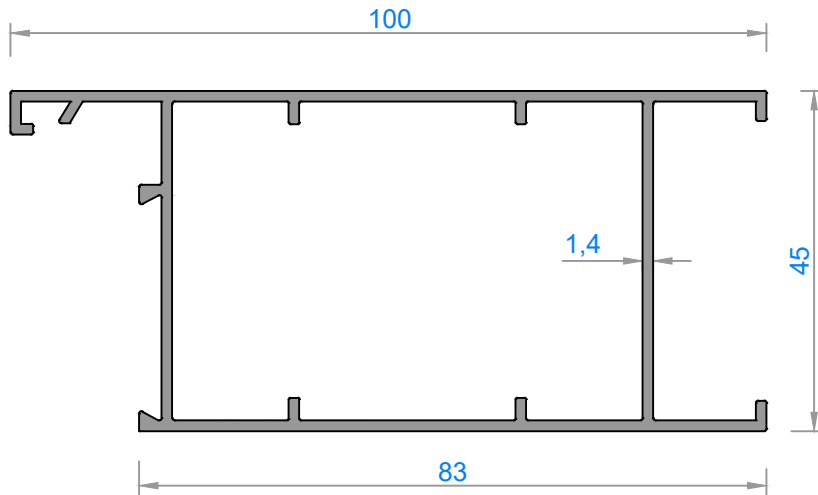

* 1239 - 1,136 kg/m

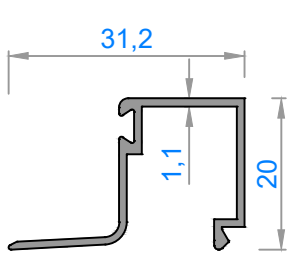

1259 - 0,212 kg/m

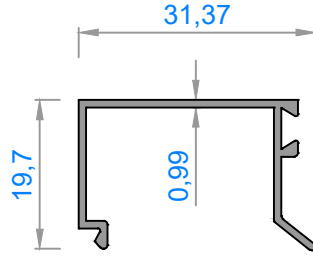

1081 - 0,209 kg/m

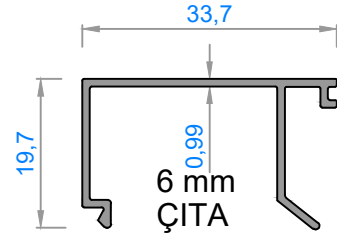

*4327 - 0,218 kg/m

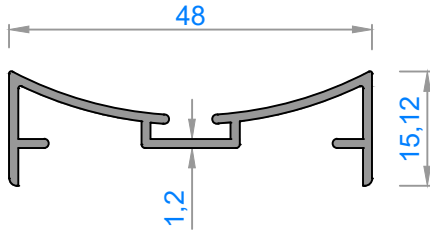

1092 - 0,314 kg/m

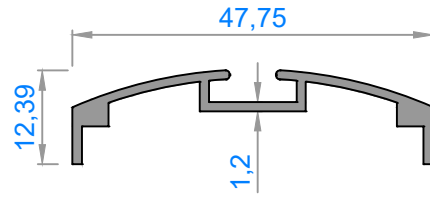

1093 - 0,295 kg/m

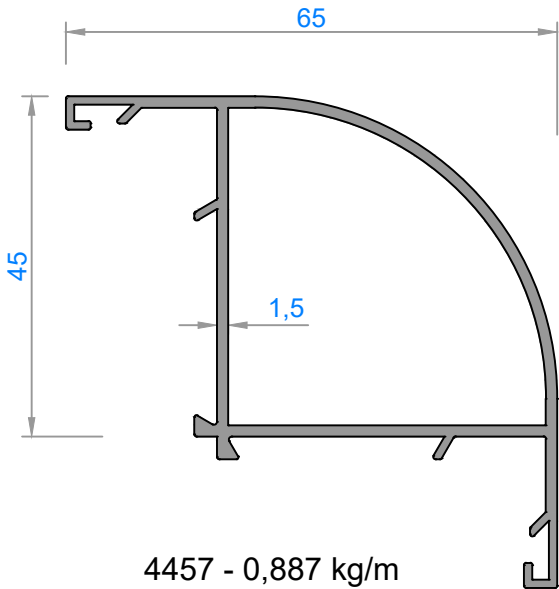

4457 - 0,887 kg/m

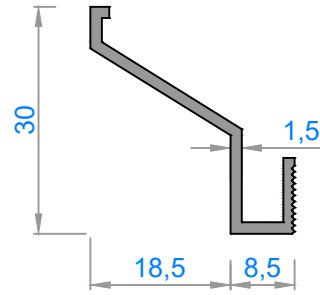

1087 - 0,228 kg/m

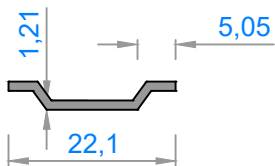

1098 - 0,081 kg/m

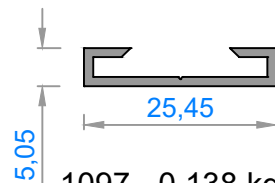

1097 - 0,138 kg/m

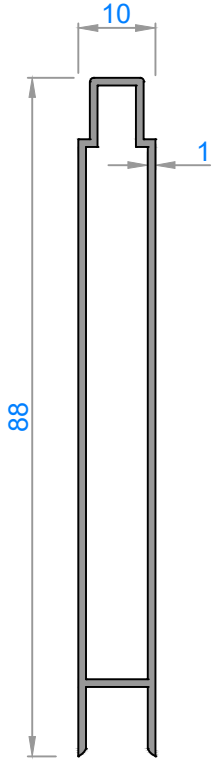

1083 - 0,518 kg/m

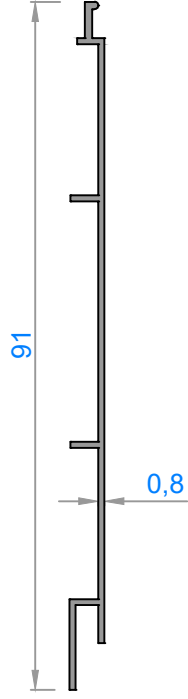

1211 - 0,245 kg/m

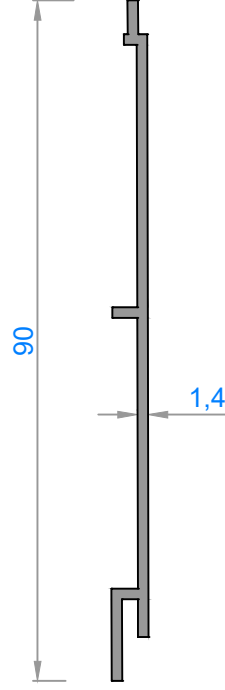

1084 - 0,391 kg/m

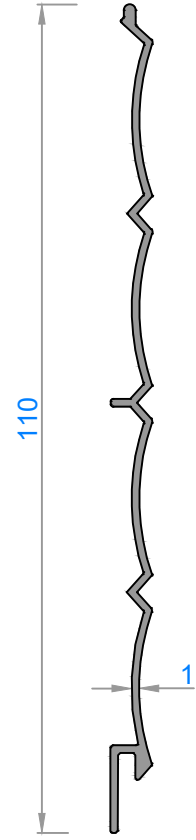

1085 - 0,360 kg/m

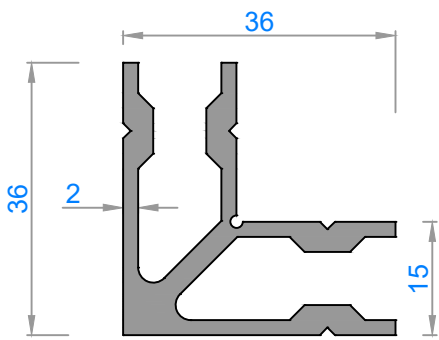

1088 - 0,929 kg/m

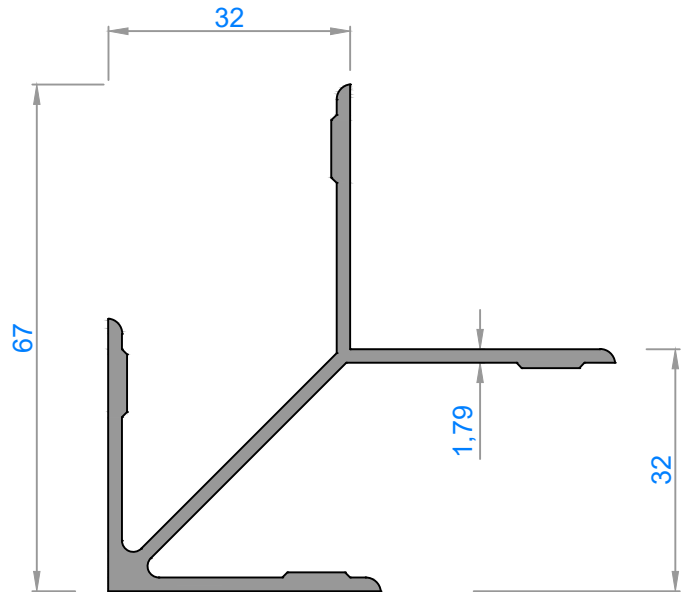

1089 - 0,953 kg/m

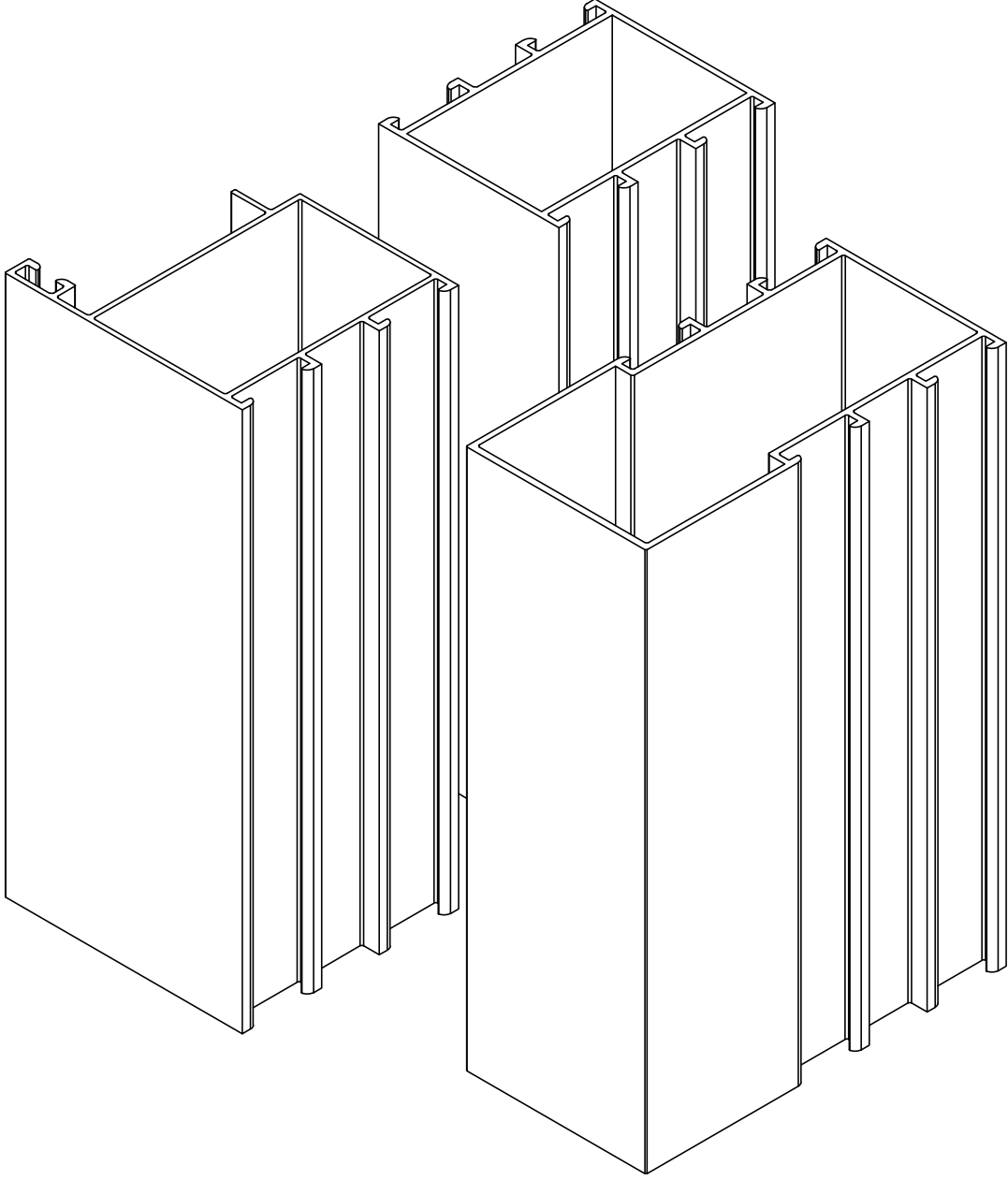

C-60 SERİSİ / C-60 Series

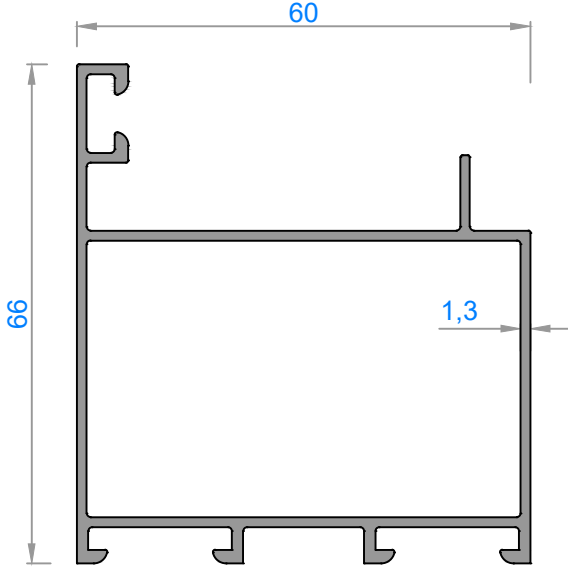

1157 - 0,975 kg/m
*1153 - 1,390 kg/m (2mm)

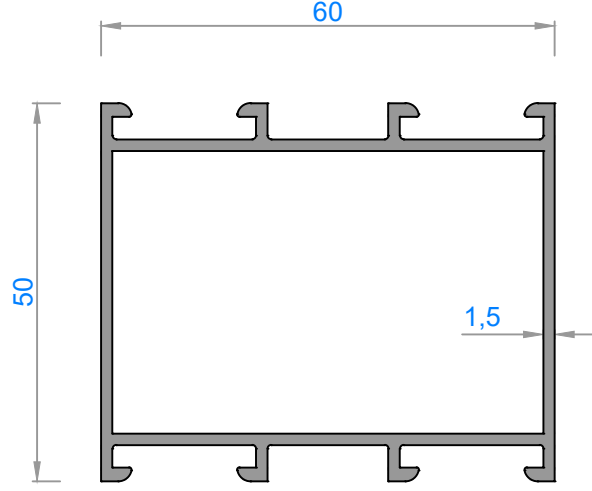

1158 - 1,033 kg/m
*1154 - 1,317 kg/m (2mm)

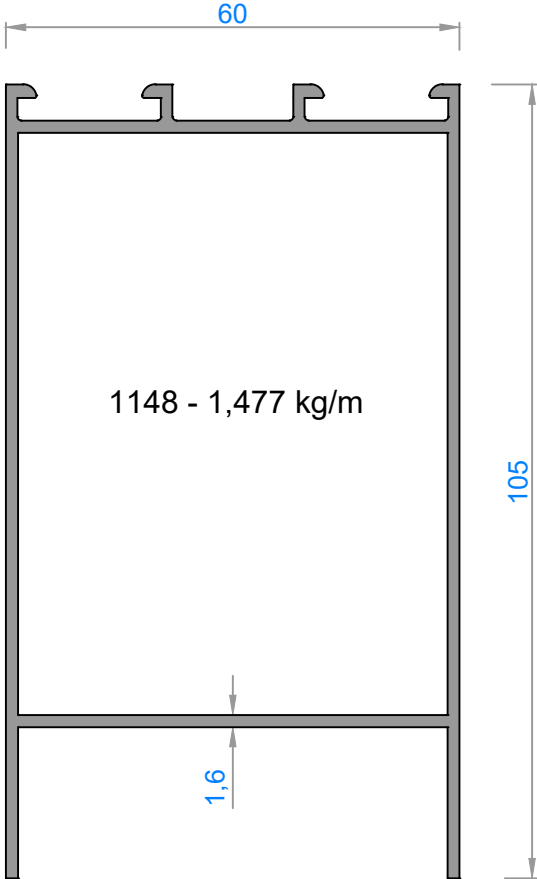

1148 - 1,477 kg/m

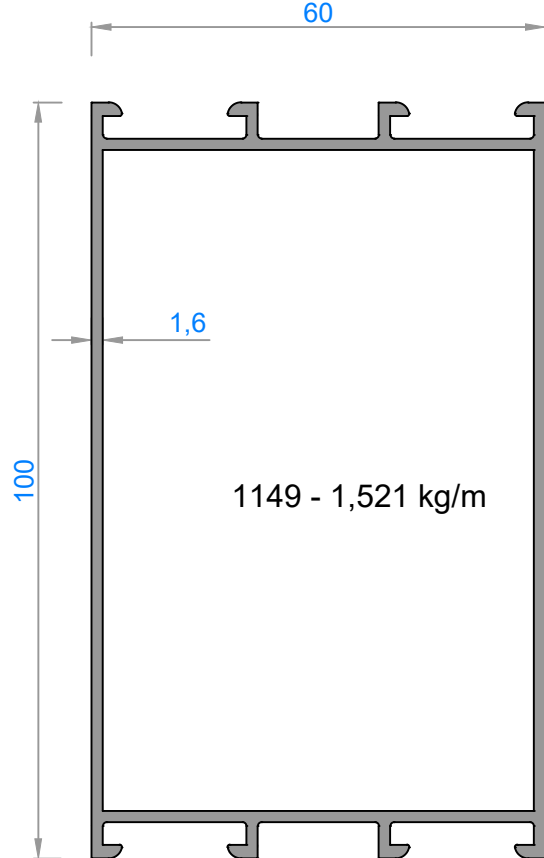

1149 - 1,521 kg/m

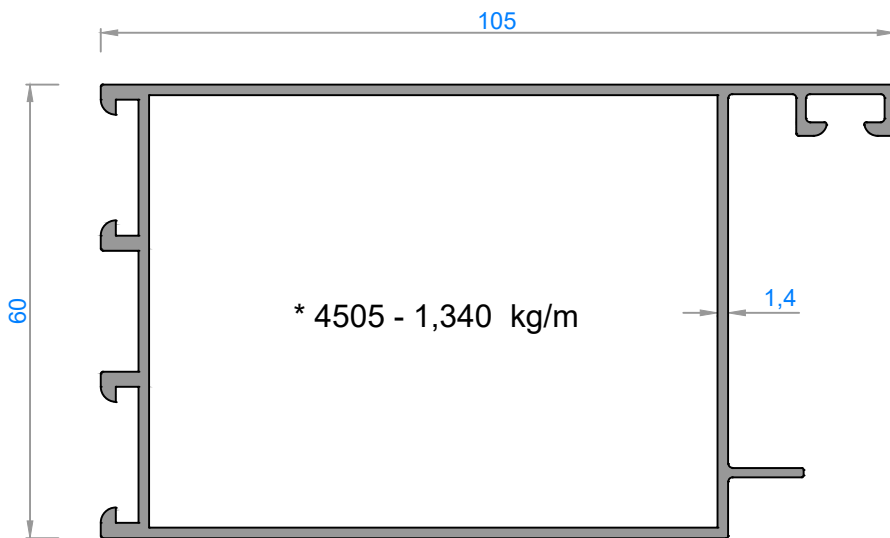
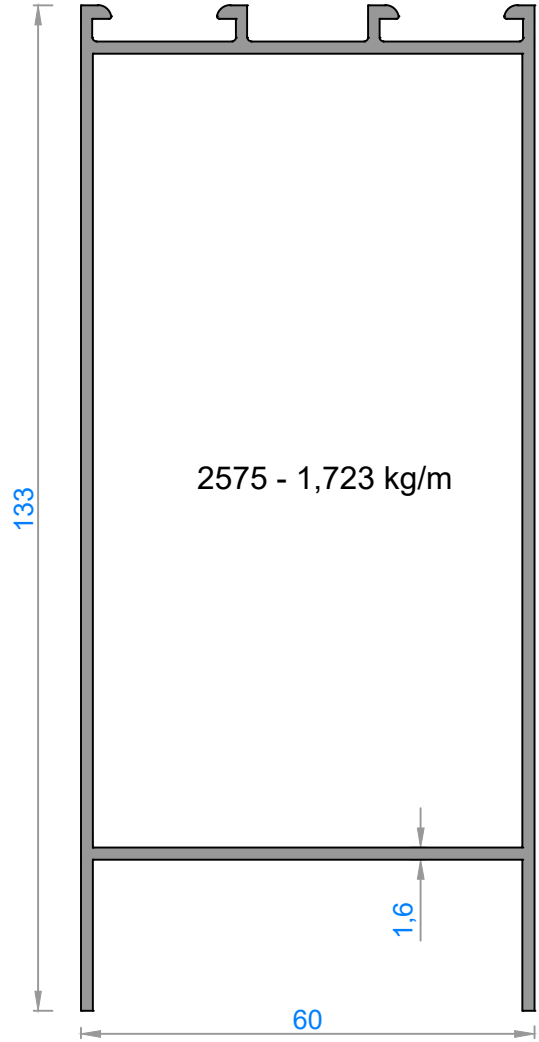
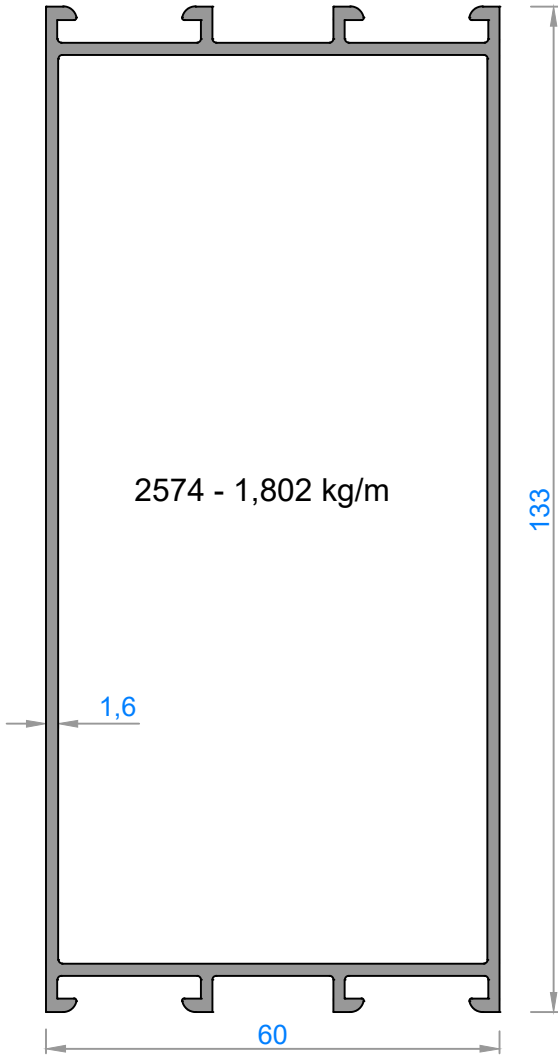

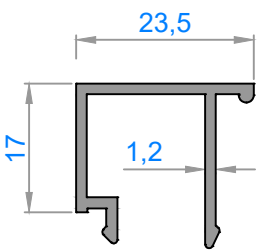
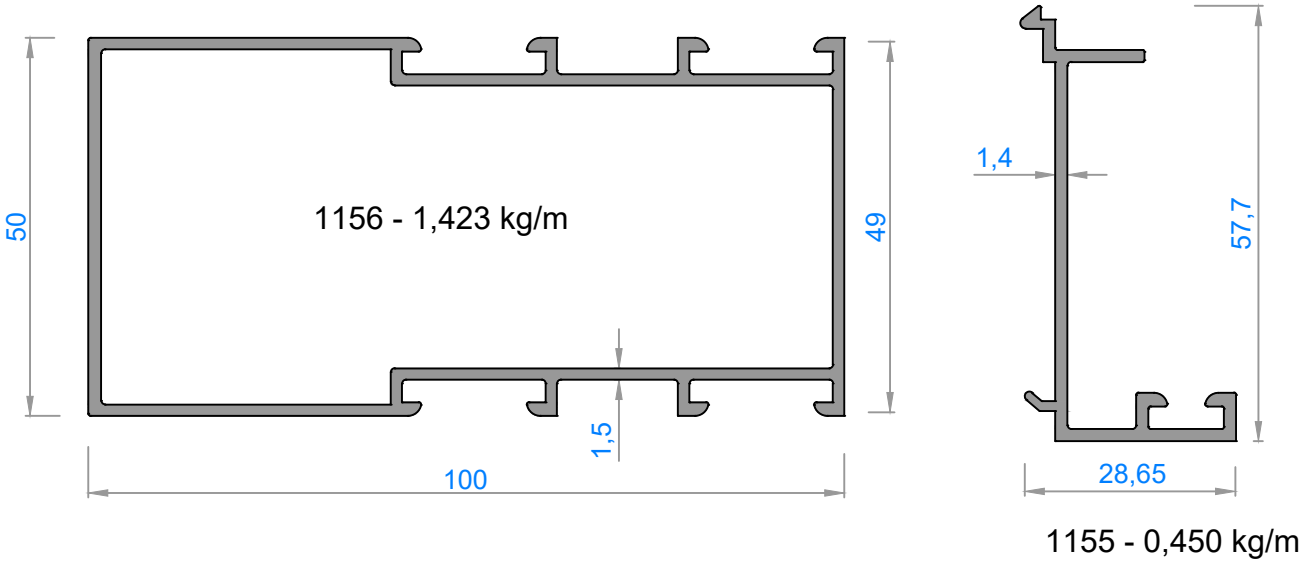
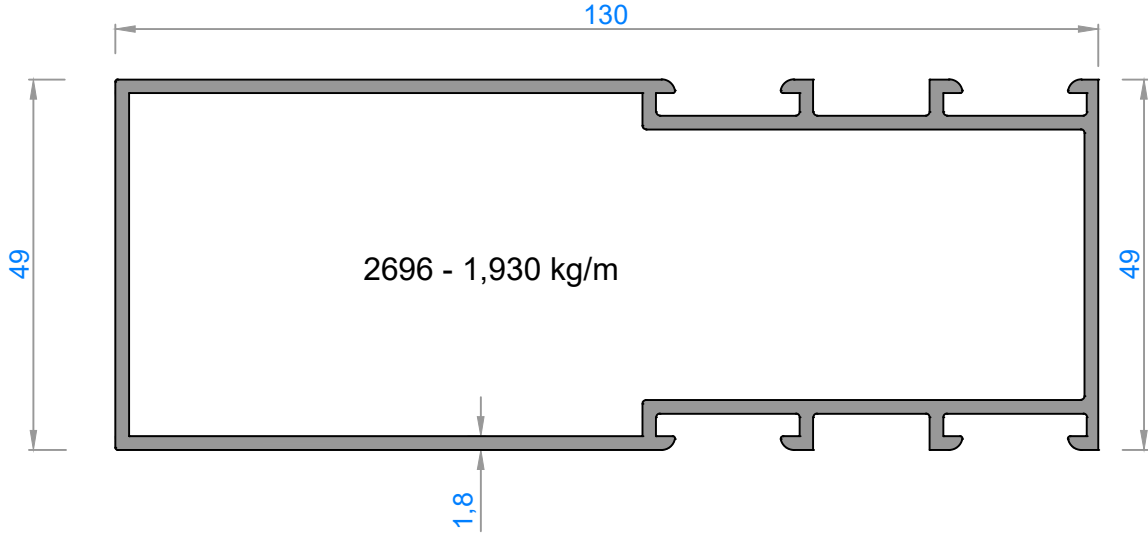

1151 - 0,232 kg/m

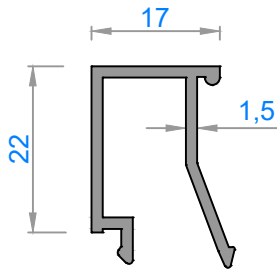

1152 - 0,298 kg/m

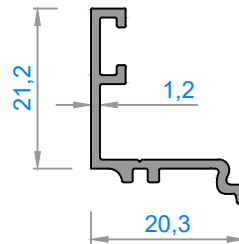

* 4502 - 0,192 kg/m

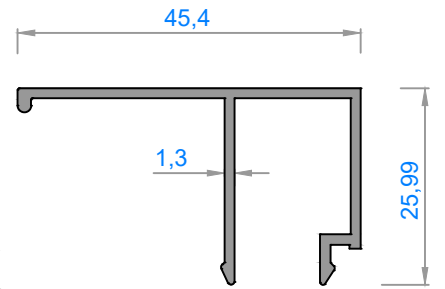

* 4503 - 0,361 kg/m

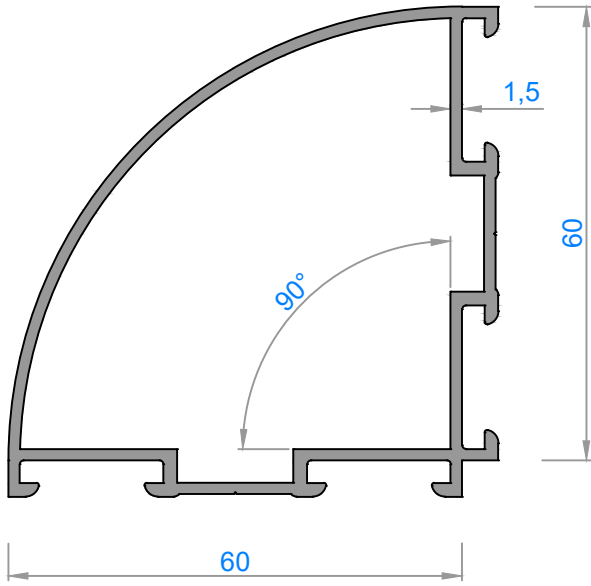

1248 - 1,106 kg/m

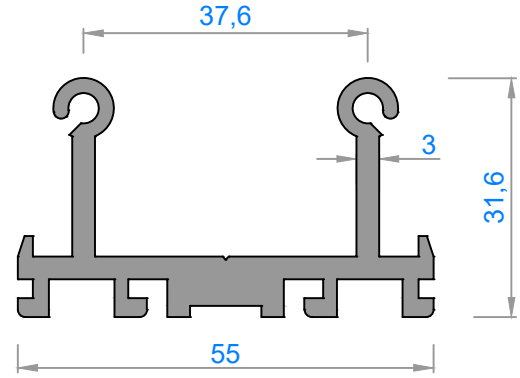

1247 - 1,238 kg/m

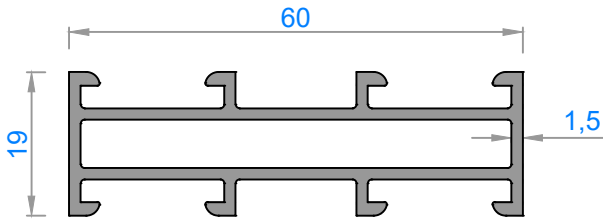

1150 - 0,784 kg/m

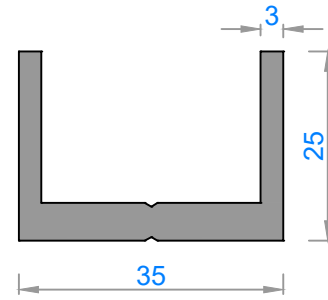

2577 - 0,800 kg/m

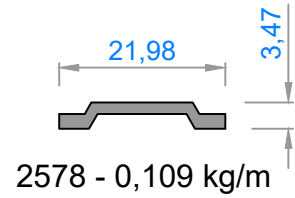

2578 - 0,109 kg/m

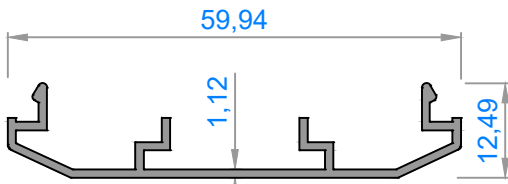

2580 - 0,324 kg/m

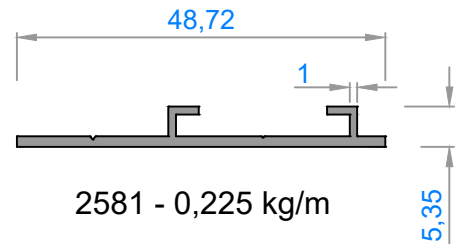

2581 - 0,225 kg/m

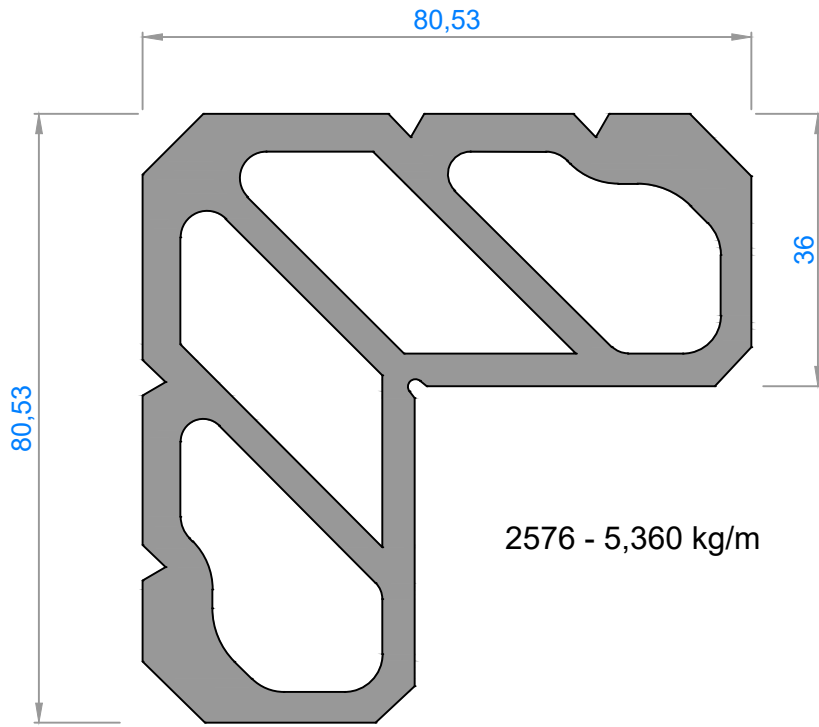
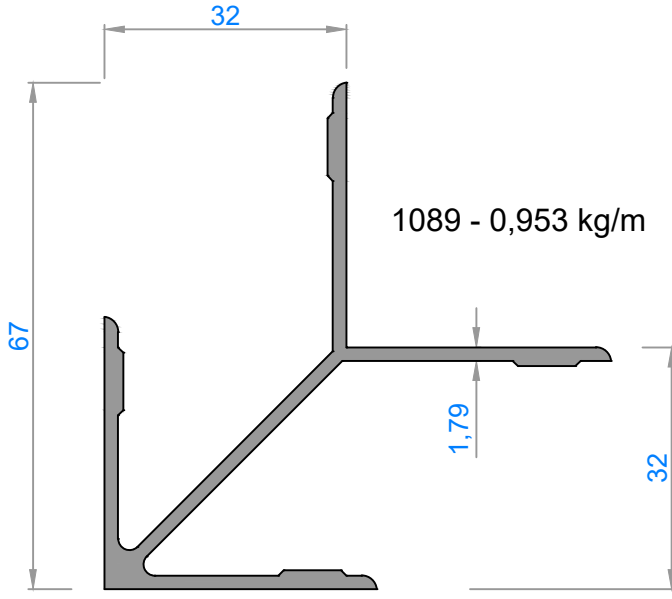

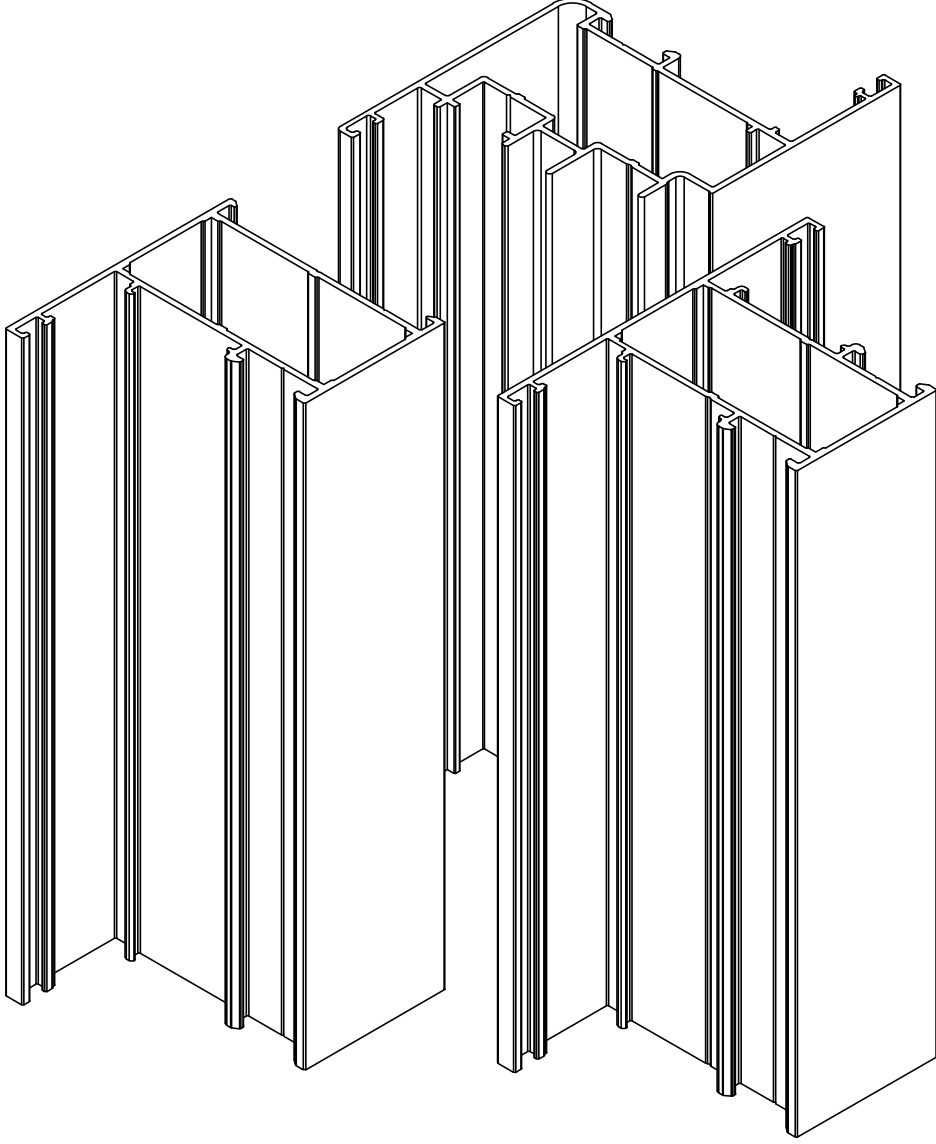

55' LİK YALITIMSIZ SERİ / 55'lik Non-Insulated Series

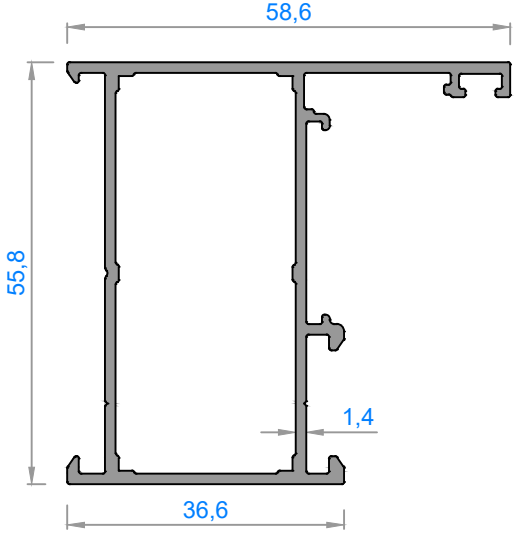

Sistem Kodu : 6175

Ağırlık (kg/mt): 0,876

Statik J_x (cm⁴): 15,83

Statik J_y (cm⁴): 6,70

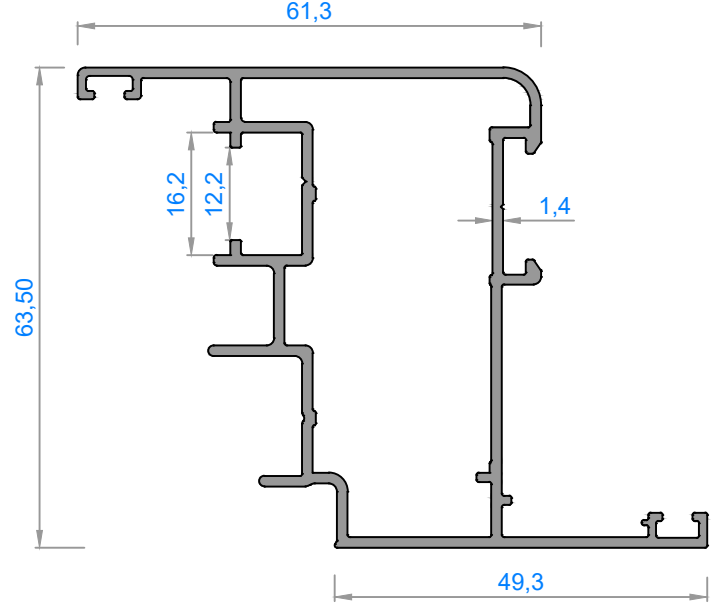

Sistem Kodu : 6176

Ağırlık (kg/mt): 1,175

Statik J_x (cm⁴): 29,03

Statik J_y (cm⁴): 9,83

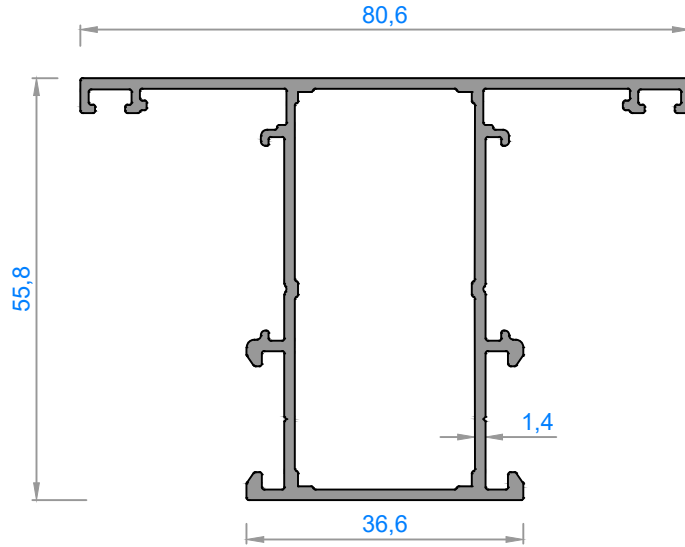

Sistem Kodu : 6177

Ağırlık (kg/mt): 1,027

Statik J_x (cm⁴): 17,24

Statik J_y (cm⁴): 12,88

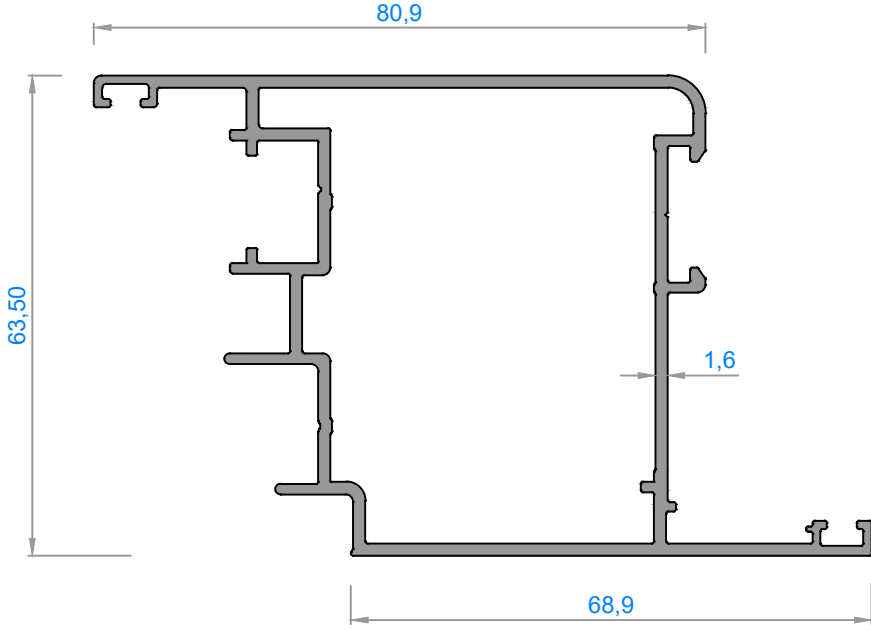

Sistem Kodu : 6178

Ağırlık (kg/mt): 1,463

Statik J_x (cm⁴): 21,56

Statik J_y (cm⁴): 46,68

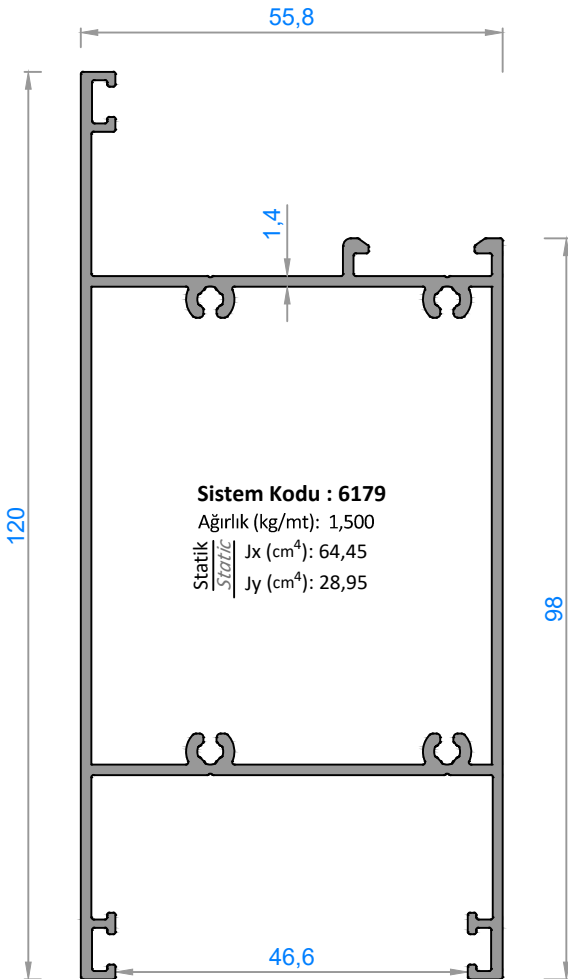

Sistem Kodu : 6179

Ağırlık (kg/mt): 1,500

Statik J_x (cm⁴): 64,45

Statik J_y (cm⁴): 28,95

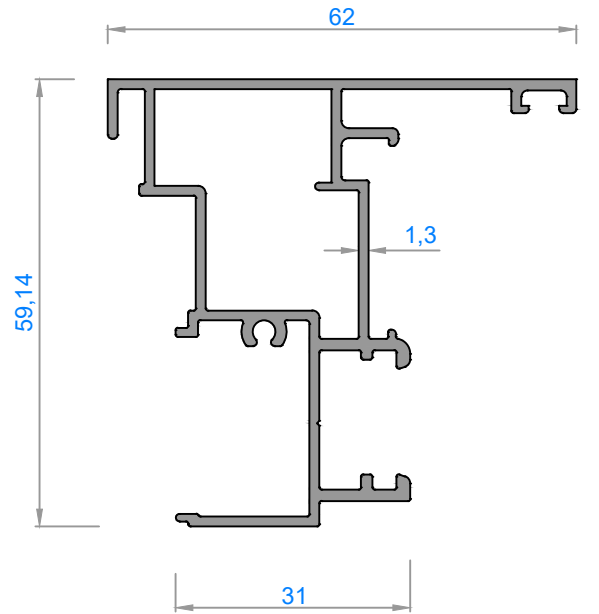

Sistem Kodu : 6180

Ağırlık (kg/mt): 0,962

Statik J_x (cm⁴): 14,25

Statik J_y (cm⁴): 7,12

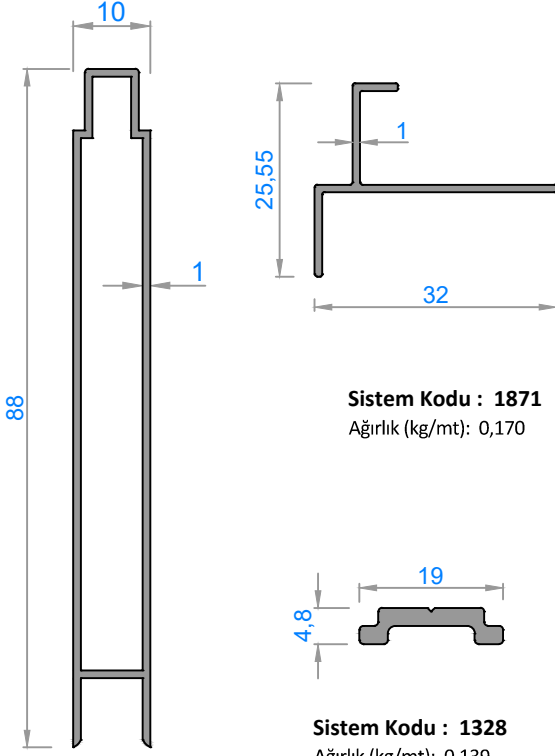

Sistem Kodu : 1871
Ağırlık (kg/mt): 0,170

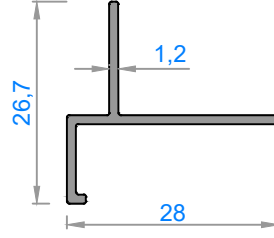

Sistem Kodu : 1040
Ağırlık (kg/mt): 0,180

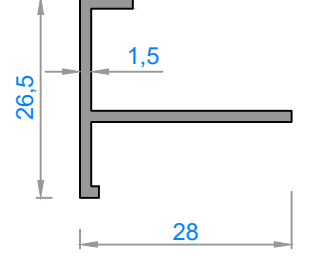

Sistem Kodu : 1935
Ağırlık (kg/mt): 0,242

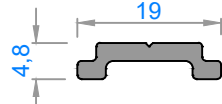

Sistem Kodu : 1328
Ağırlık (kg/mt): 0,139

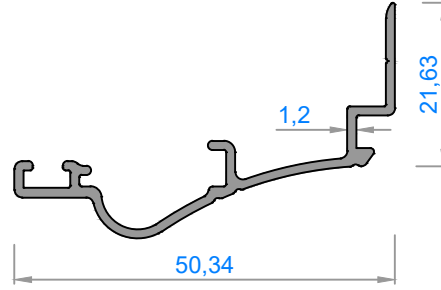

Sistem Kodu : ALC56-500
Ağırlık (kg/mt): 0,325

Sistem Kodu : 1083
Ağırlık (kg/mt): 0,518

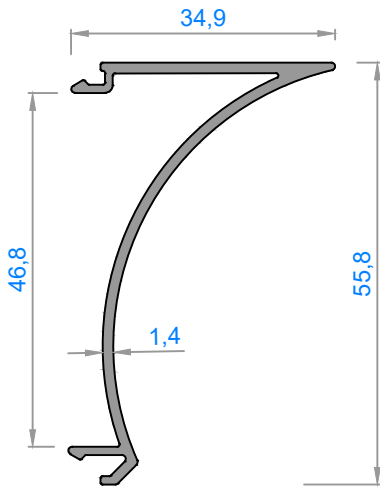

Sistem Kodu : 6153
Ağırlık (kg/mt): 0,418
Statik J_x (cm⁴): 6,30
Statik J_y (cm⁴): 0,63

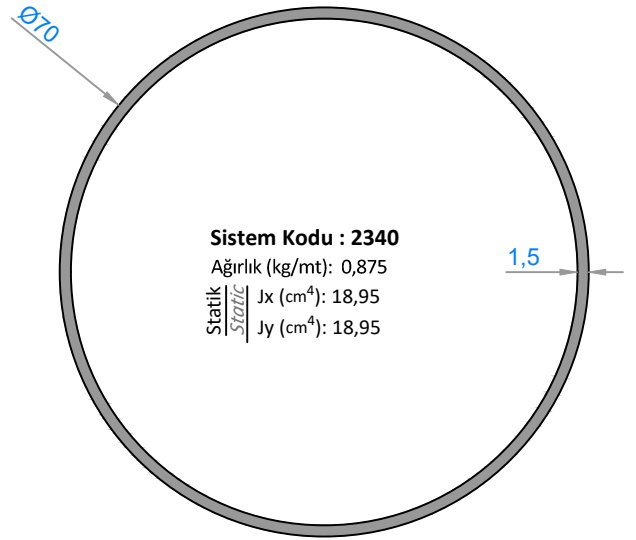

Sistem Kodu : 2340
Ağırlık (kg/mt): 0,875
Statik J_x (cm⁴): 18,95
Statik J_y (cm⁴): 18,95

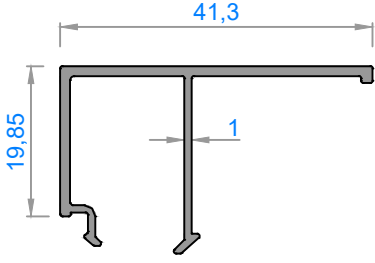

Sistem Kodu : 6155
Ağırlık (kg/mt): 0,304

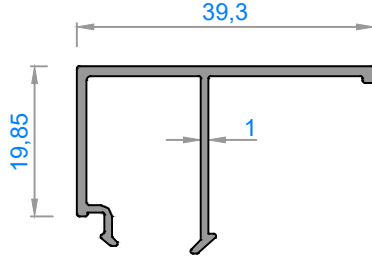

Sistem Kodu : 6156
Ağırlık (kg/mt): 0,303

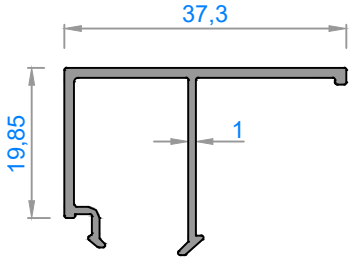

Sistem Kodu : 6157
Ağırlık (kg/mt): 0,296

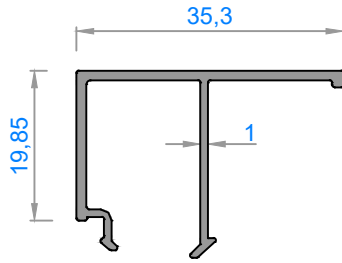

Sistem Kodu : 6158
Ağırlık (kg/mt): 0,283

CAM ÇITASI GLAZING BEAD	İÇ CAM FITİLİ GLAZING GASKET	CAM KALINLIĞI GLASS THICKNESS	DIŞ CAM FITİLİ GLAZING GASKET
6155	FTL01	4mm	FTL02
6156	FTL01	6mm	FTL02
6157	FTL01	8mm	FTL02
6158	FTL01	10mm	FTL02
6159	FTL01	12mm	FTL02
6160	FTL01	14mm	FTL02
6161	FTL01	16mm	FTL02
6162	FTL01	18mm	FTL02
6163	FTL01	20mm	FTL02
6164	FTL01	22mm	FTL02
6165	FTL01	24mm	FTL02
6166	FTL01	26mm	FTL02
6167	FTL01	28mm	FTL02
6168	FTL01	30mm	FTL02

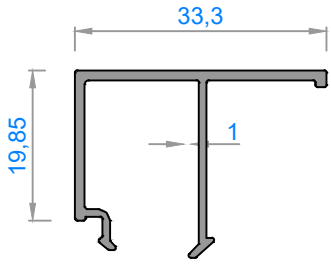

Sistem Kodu : 6159
Ağırlık (kg/mt): 0,282

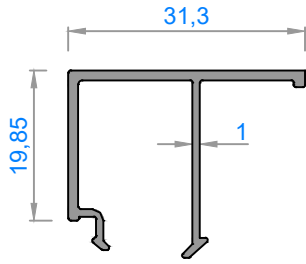

Sistem Kodu : 6160
Ağırlık (kg/mt): 0,275

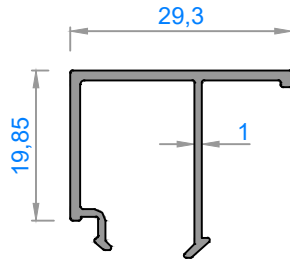

Sistem Kodu : 6161
Ağırlık (kg/mt): 0,268

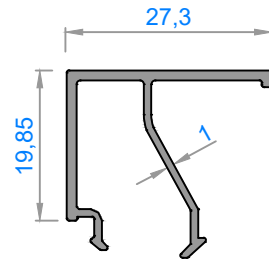

Sistem Kodu : 6162
Ağırlık (kg/mt): 0,264

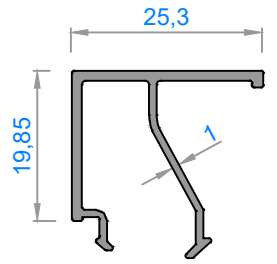

Sistem Kodu : 6163
Ağırlık (kg/mt): 0,251

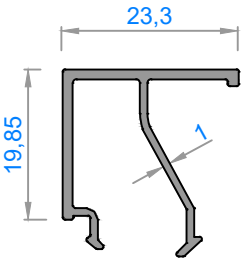

Sistem Kodu : 6164
Ağırlık (kg/mt): 0,250

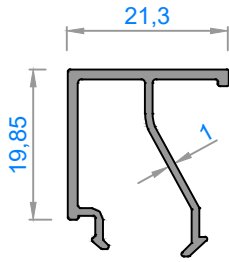

Sistem Kodu : 6165
Ağırlık (kg/mt): 0,237

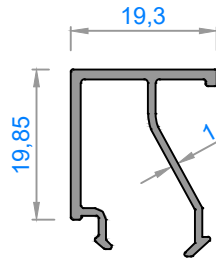

Sistem Kodu : 6166
Ağırlık (kg/mt): 0,236

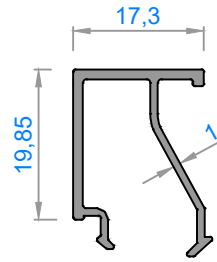

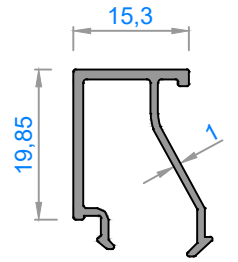

Sistem Kodu : 6167
Ağırlık (kg/mt): 0,229



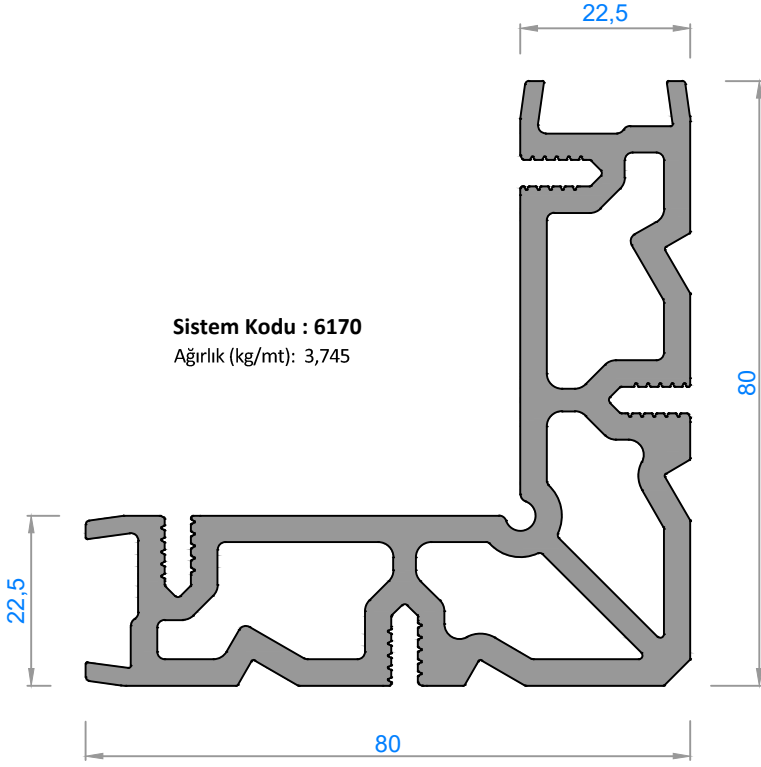

Sistem Kodu : 6168
Ağırlık (kg/mt): 0,222



Sistem Kodu : 6170
Ağırlık (kg/mt): 3,745

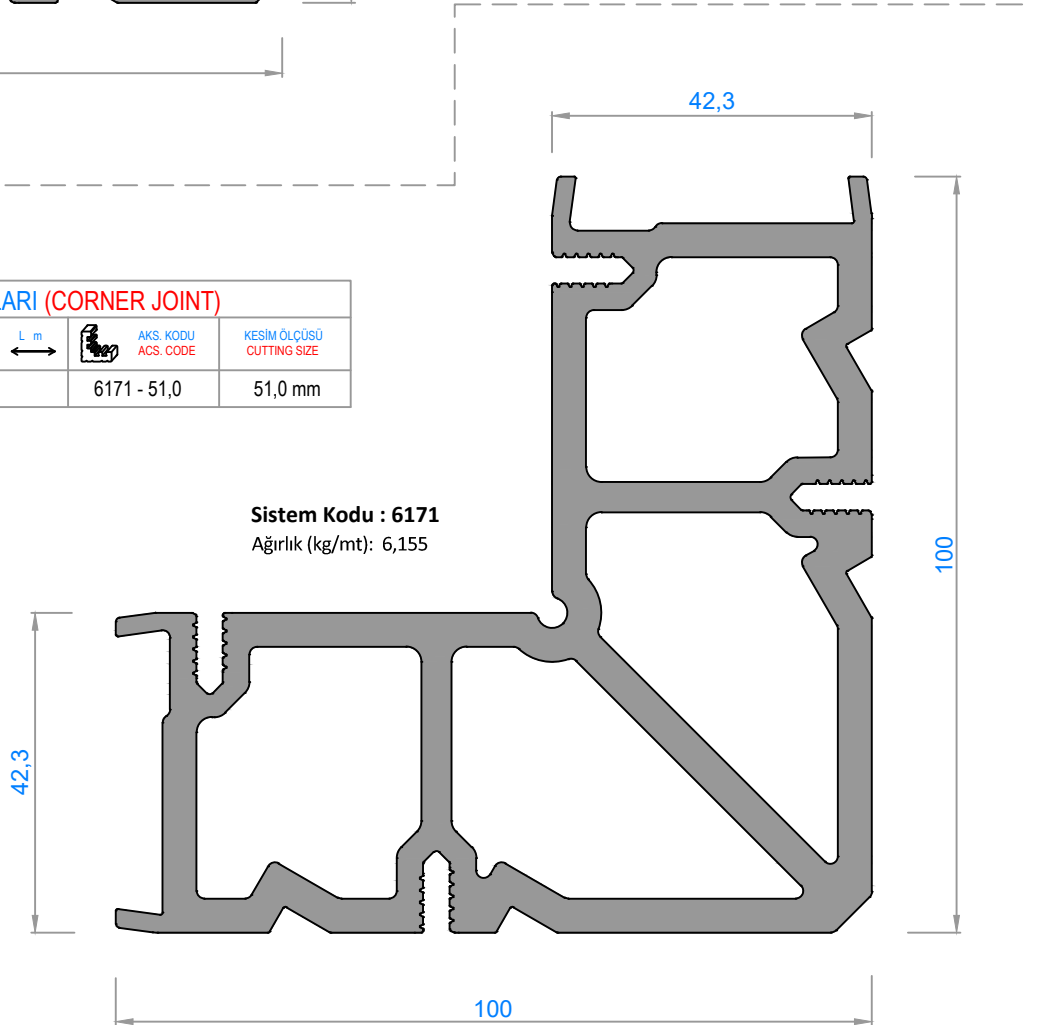

KÖŞE TAKOZLARI (CORNER JOINT)			
Nr	 L m	 AKS. KODU ACS. CODE	KESİM ÖLÇÜSÜ CUTTING SIZE
6175	6170	6170 - 51,0	51,0 mm
6176	6170	6170 - 51,0	51,0 mm
6177	6170	6170 - 51,0	51,0 mm
6180	6170	6170 - 11,9	11,9 mm

KÖŞE TAKOZLARI (CORNER JOINT)			
Nr	 L m	 AKS. KODU ACS. CODE	KESİM ÖLÇÜSÜ CUTTING SIZE
6178	6171	6171 - 51,0	51,0 mm



Sistem Kodu : 6171
Ağırlık (kg/mt): 6,155

Sistem Kodu : 6172
Ağırlık (kg/mt): 0,315

ORTA KAYIT BAĞLANTI (MULLION CONNECTION PIECE)			
Nr		AKS. KODU ACS. CODE	KESİM ÖLÇÜSÜ CUTTING SIZE
6177		6172 - 22,5	22,5 mm
		6173 - 22,5	22,5 mm

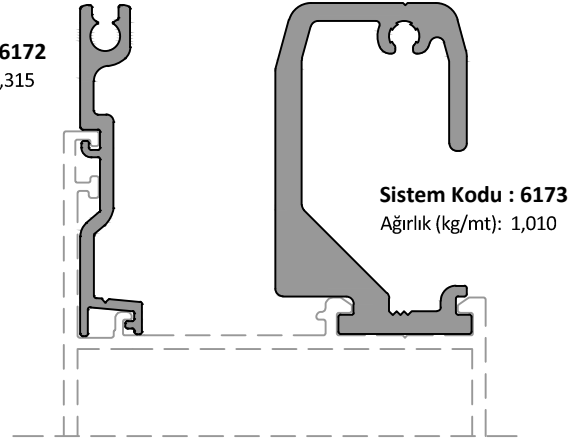

FLT01
EPDM FİTİL



FLT02
EPDM FİTİL



FLT03
EPDM FİTİL



FLT04
EPDM FİTİL

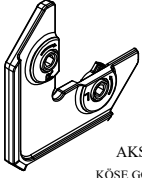

AKS01
KÖŞE GÖNYESİ
CORNER ALIGNMENT

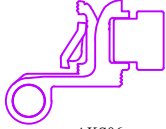

AKS06
PVC KANALLI MENTEŞE
PVC CHANNEL HINGE



AKS08
AKUSTİK KOL
ACOUSTIC HANDLE

AKS07

İSPANYOLET
MEKANİZMASI
MULTI POINT
LOCKING

ÖLÇÜLER
400-600/15
600-800/15
800-1000/15
1000-1200/15
1200-1400/15
1400-1600/15
1600-1800/15
1800-2000/15
2000-2600/15

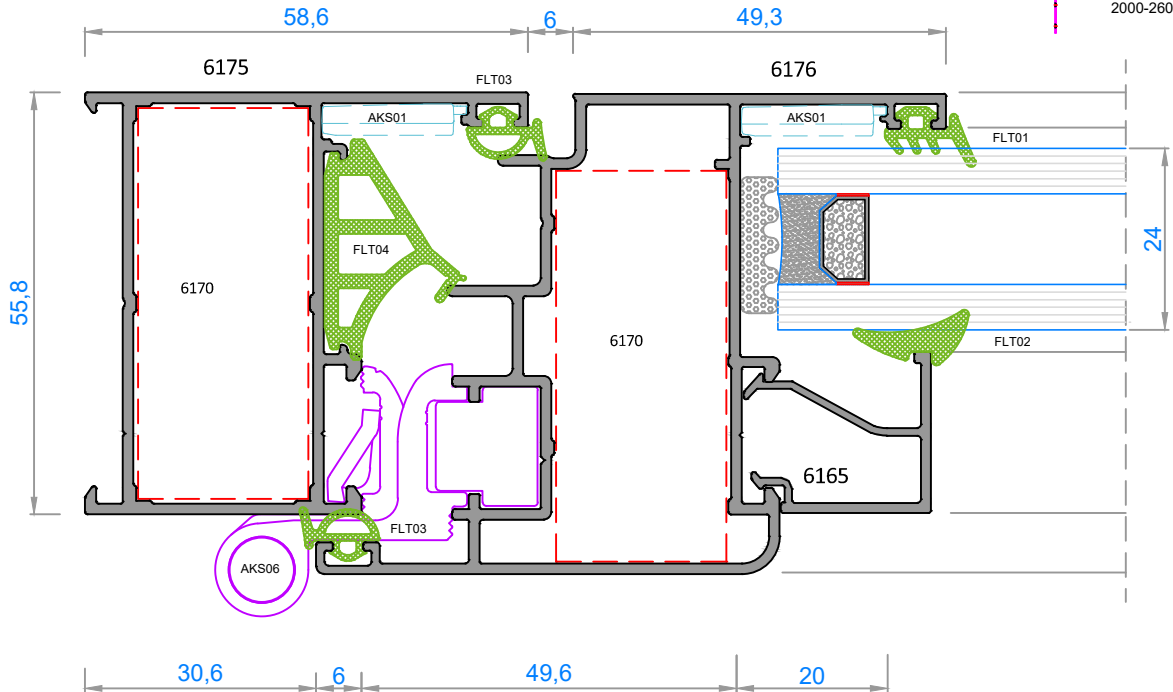

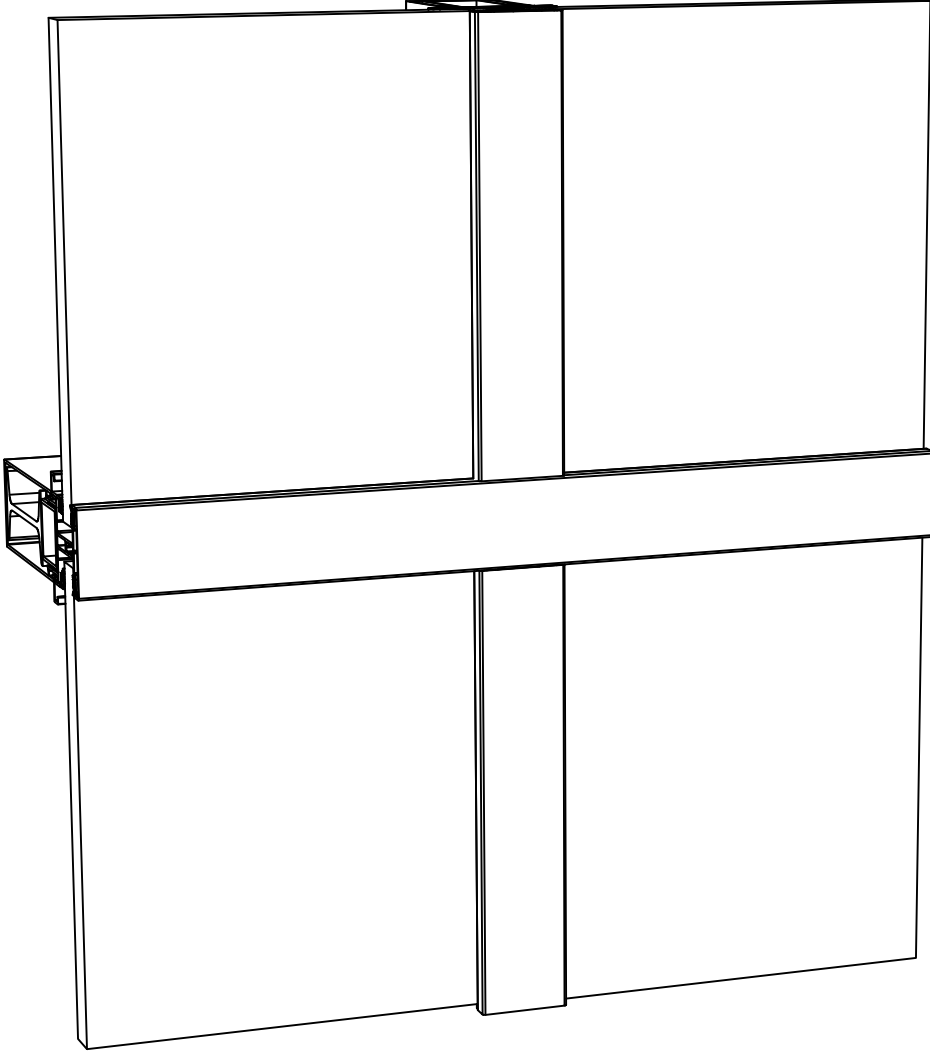

FC - 50 CEPHE SİSTEMİ / FC - 50 Facade Systems

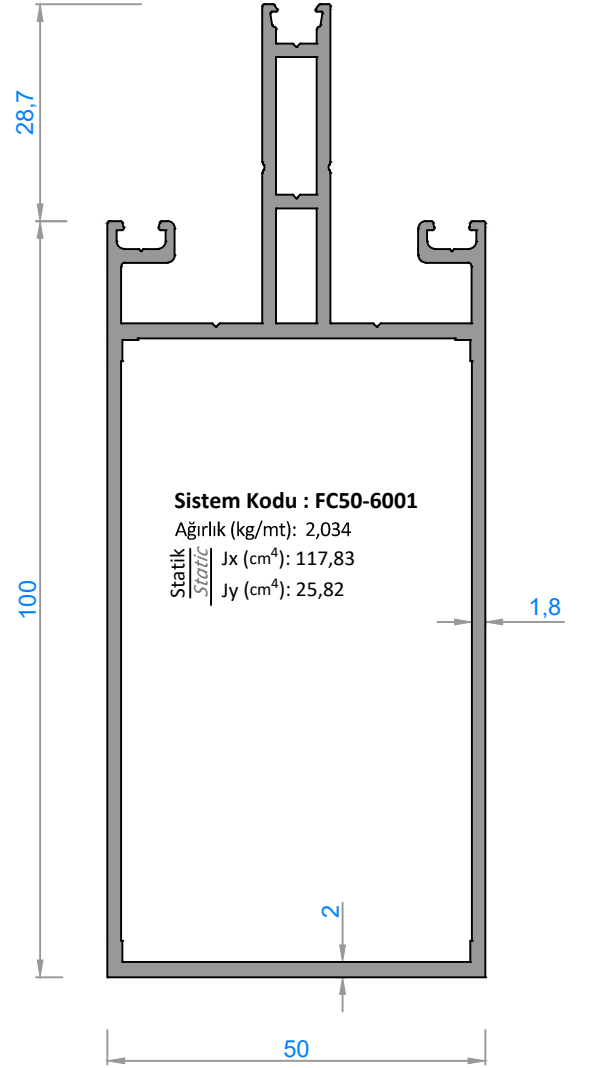
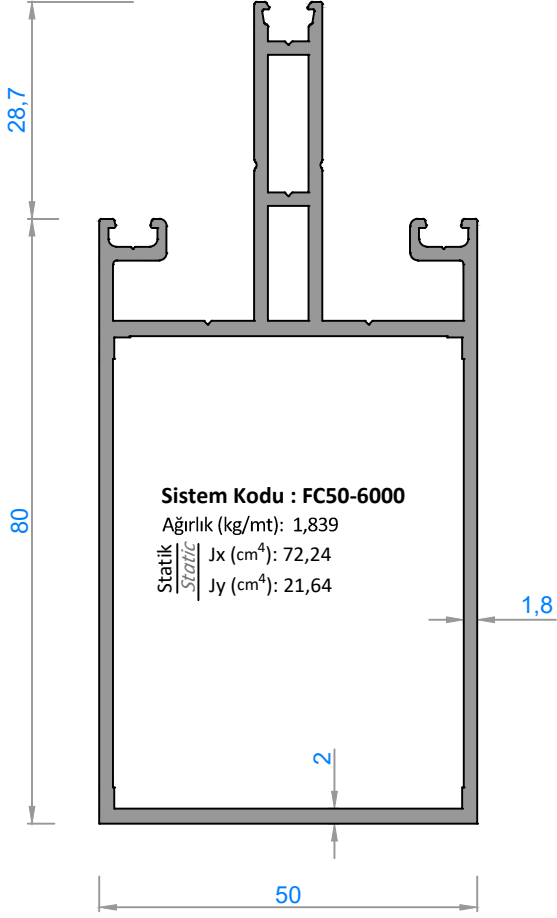

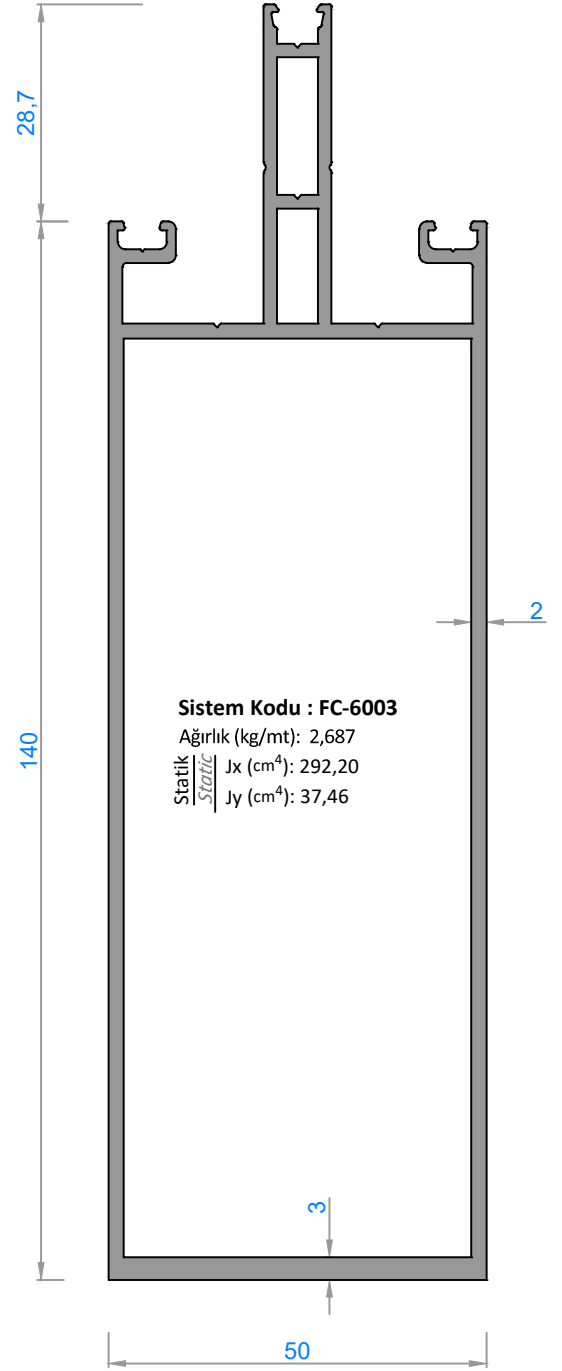
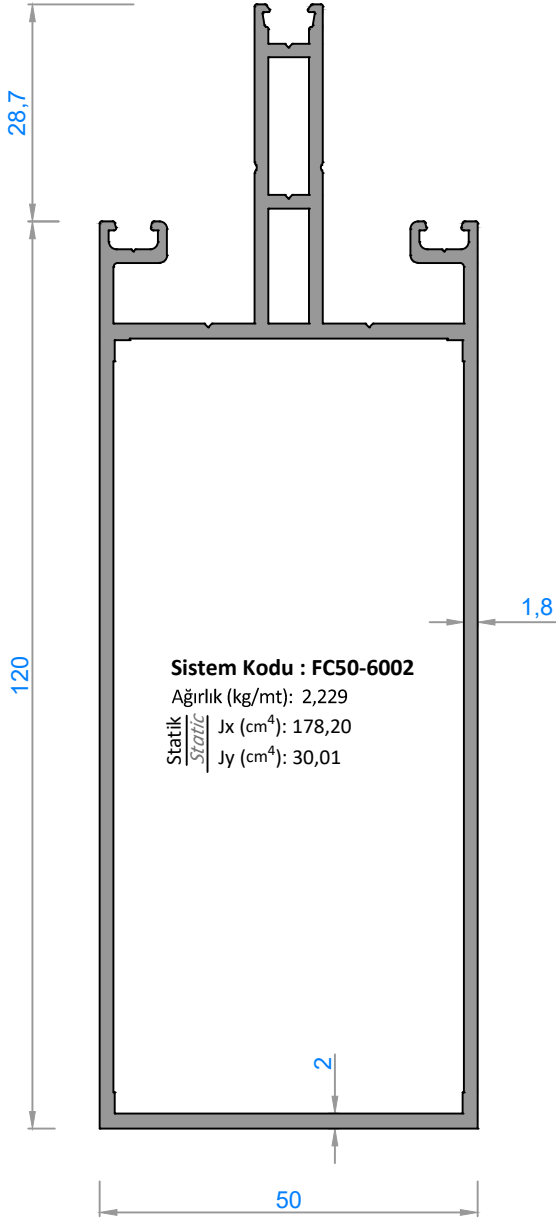

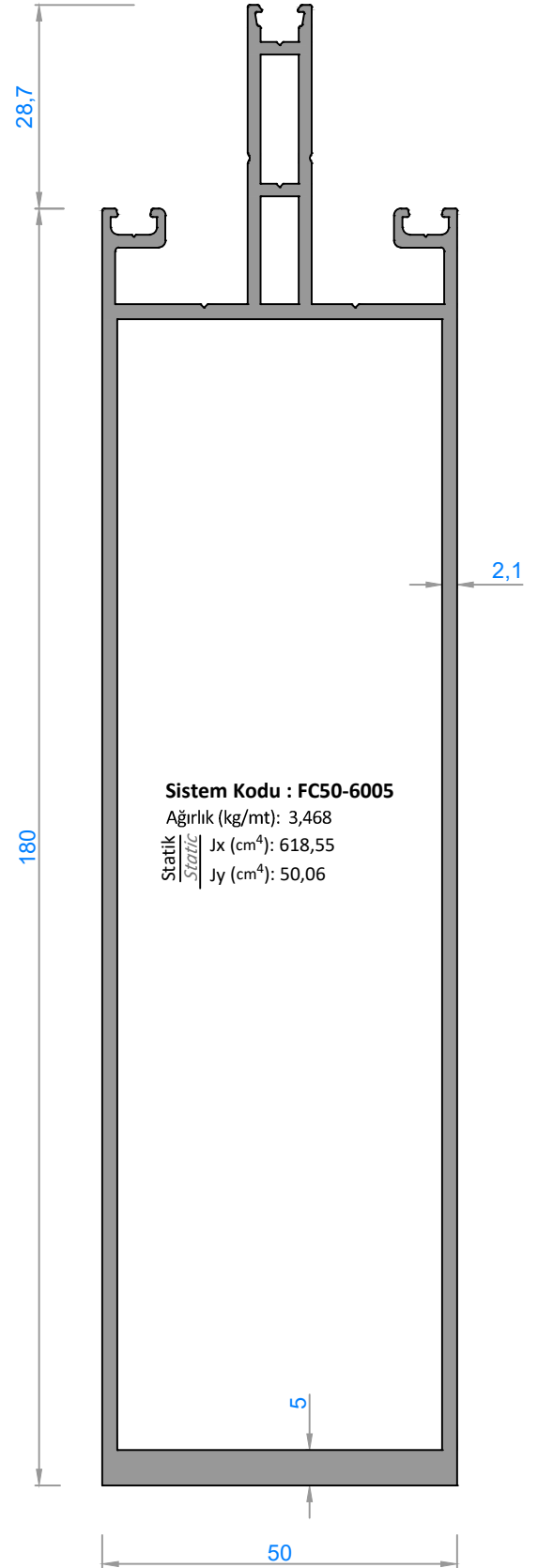
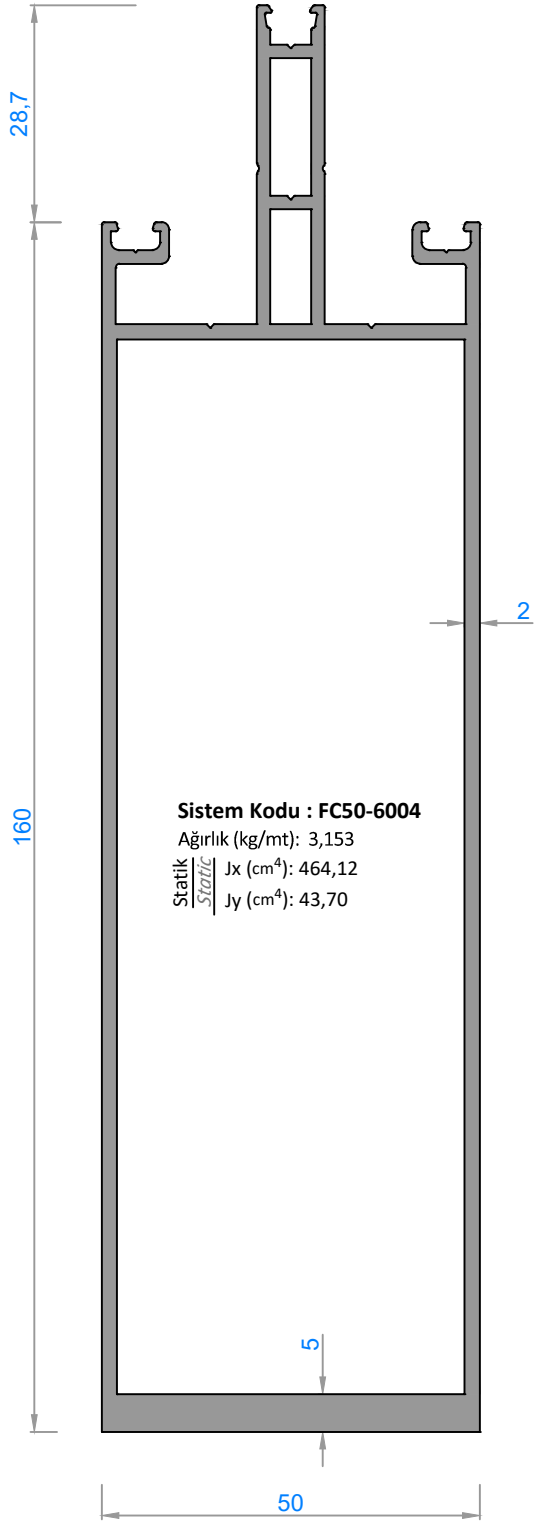

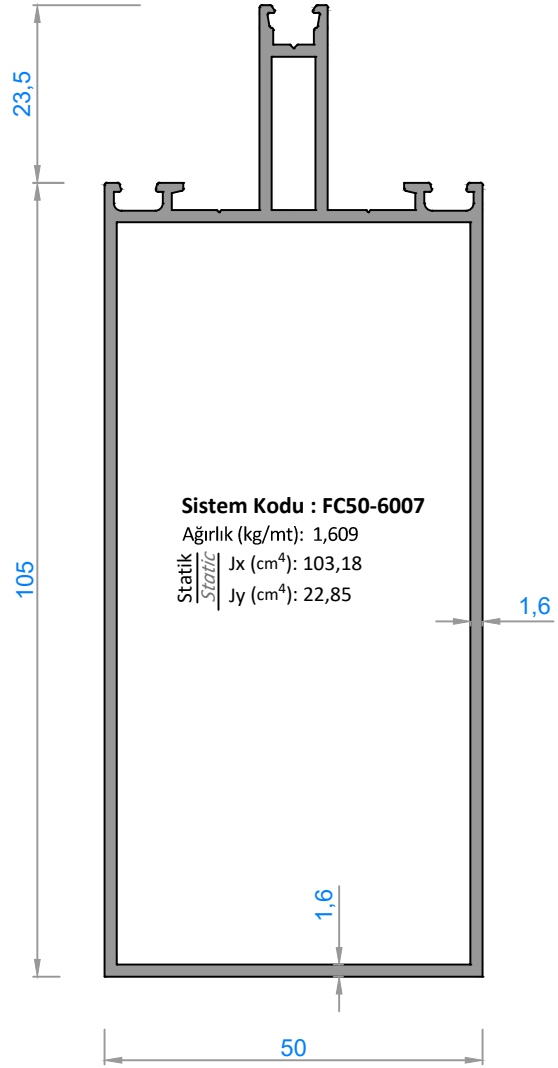
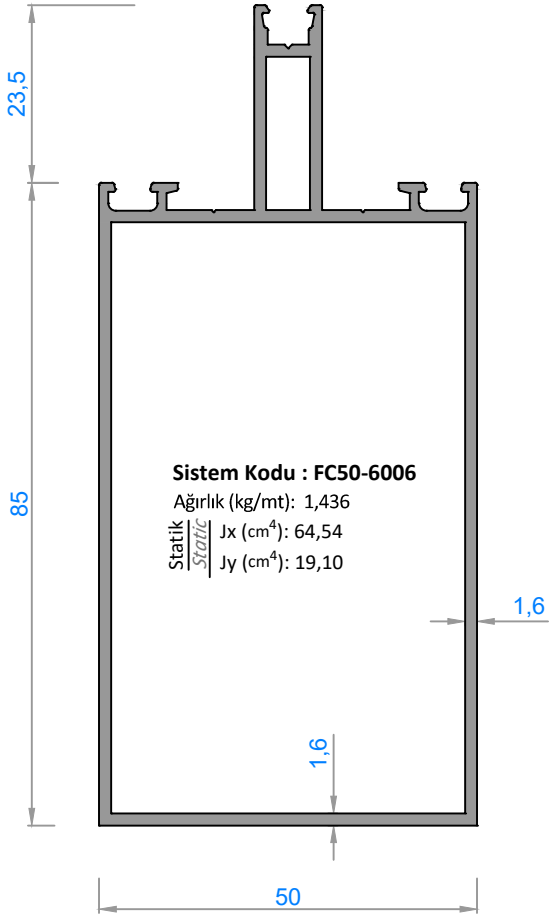

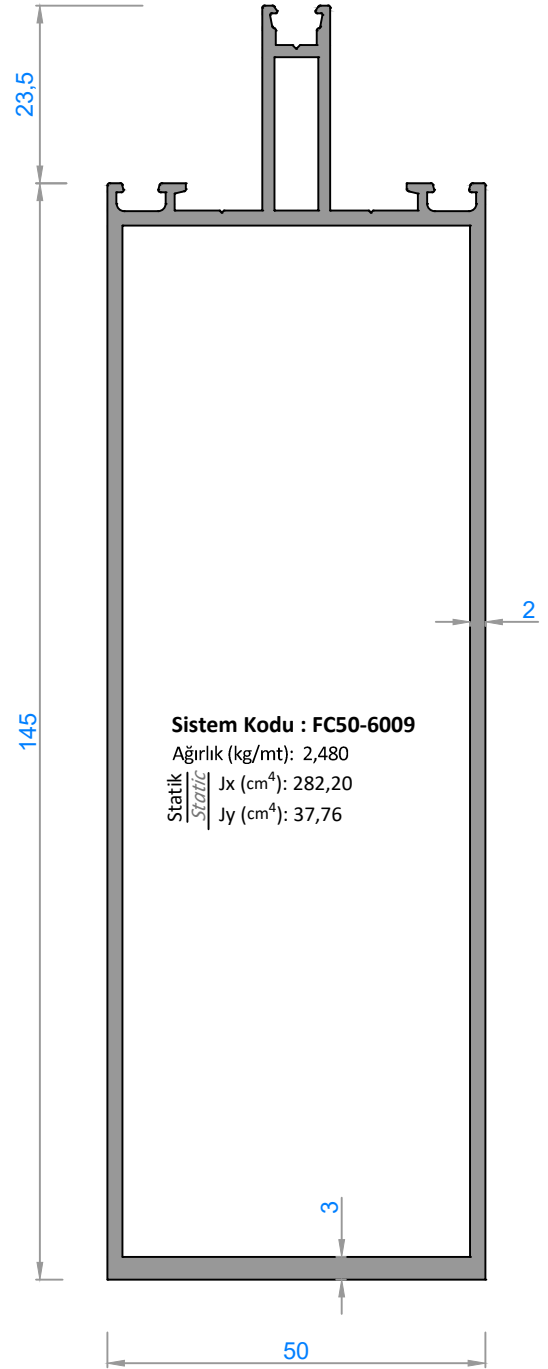
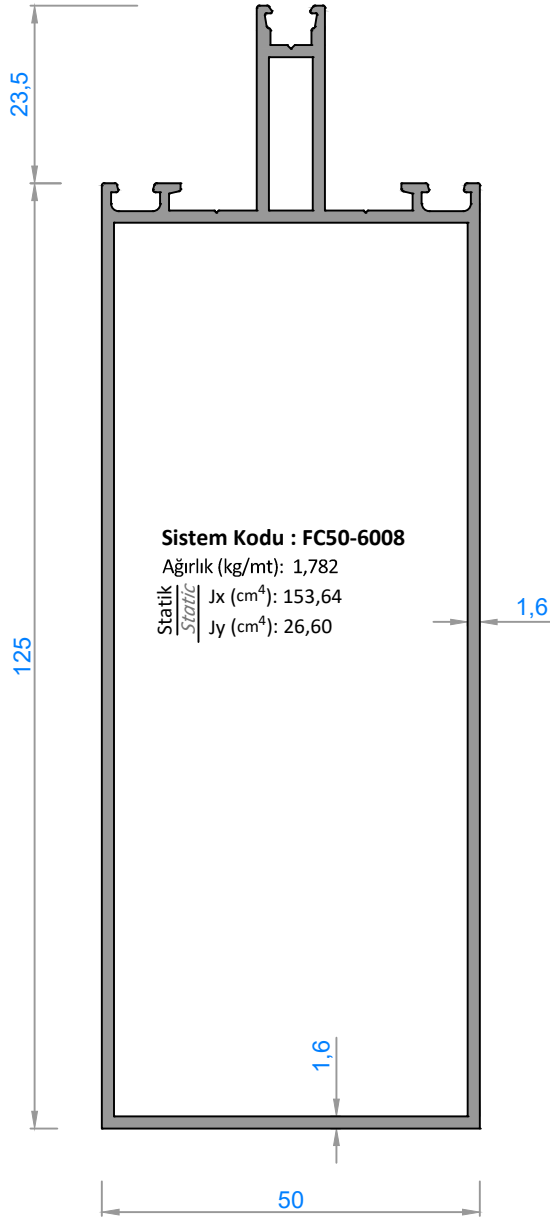

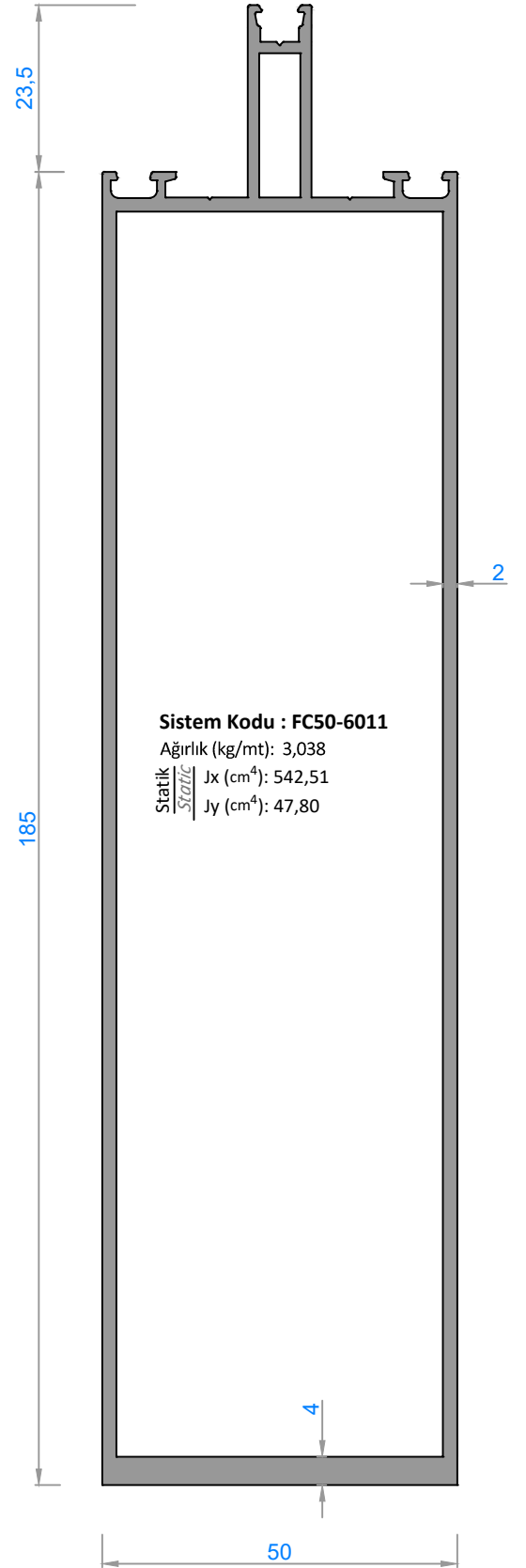
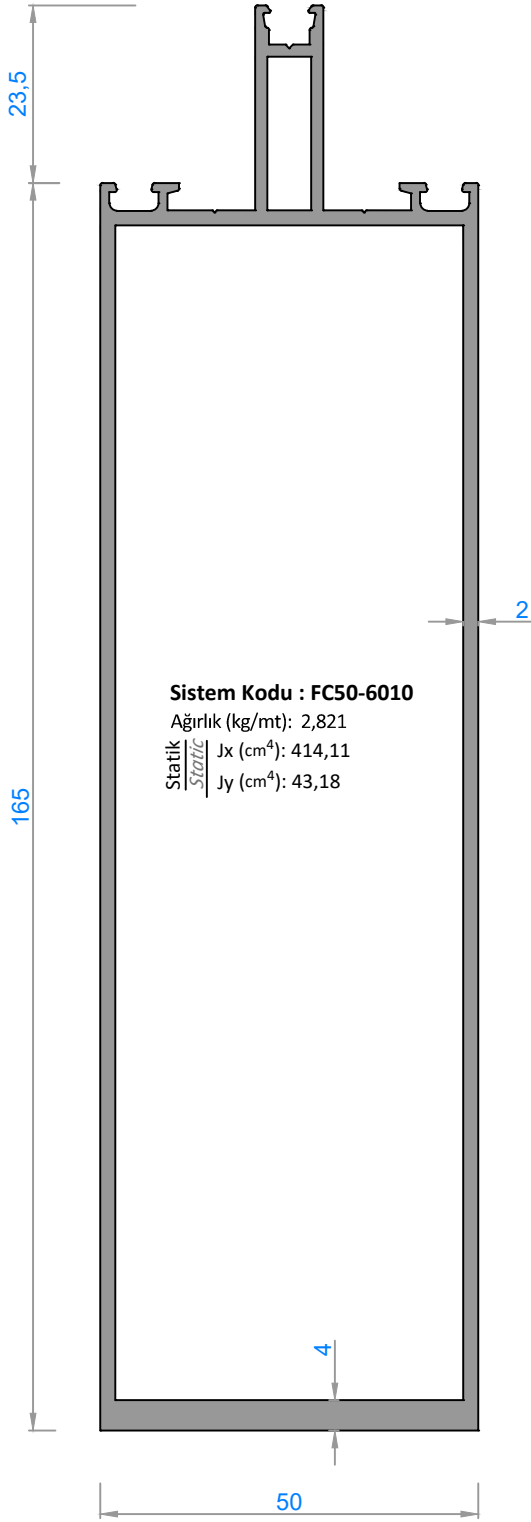

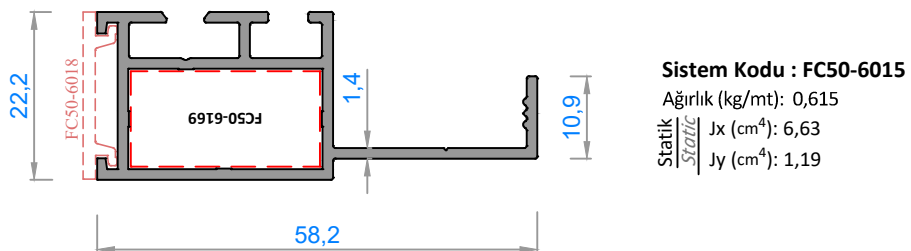
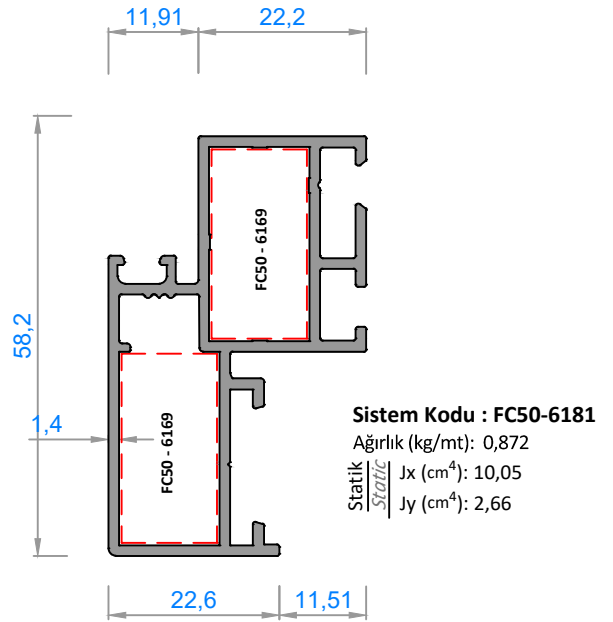
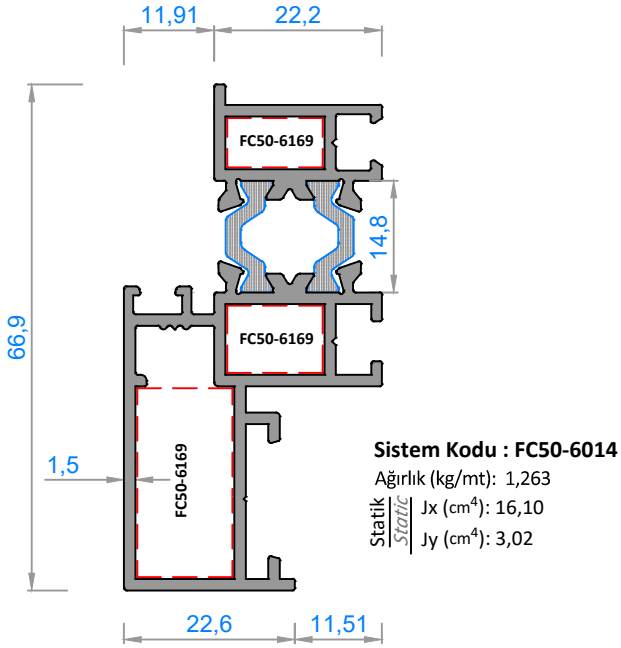
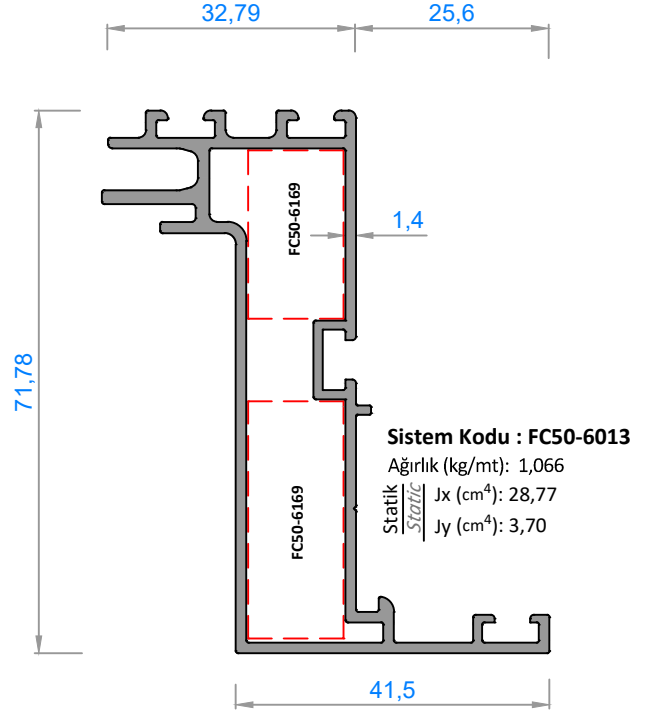
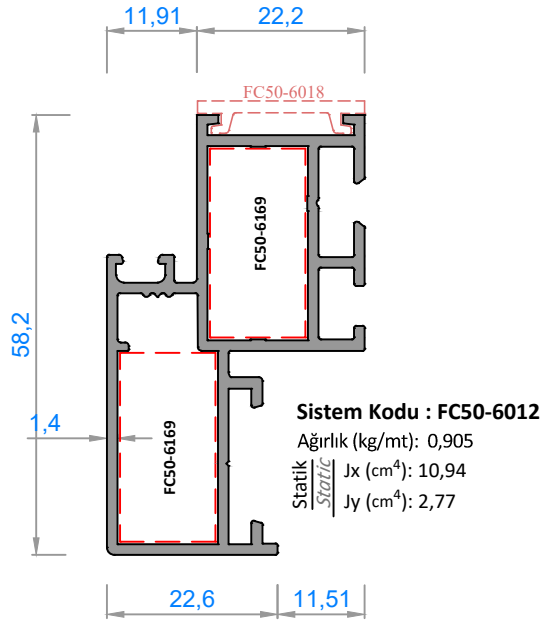

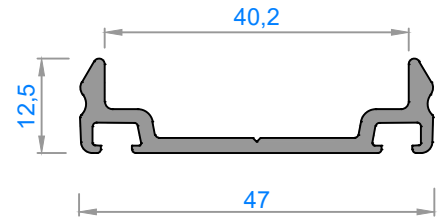
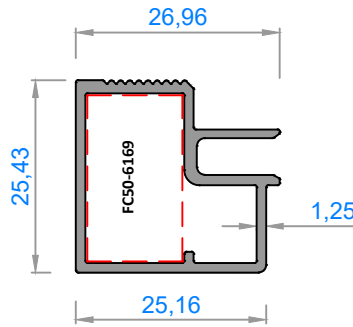
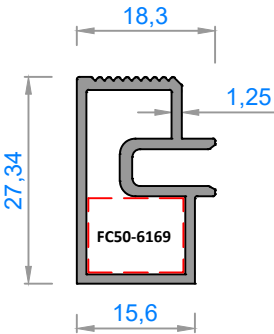
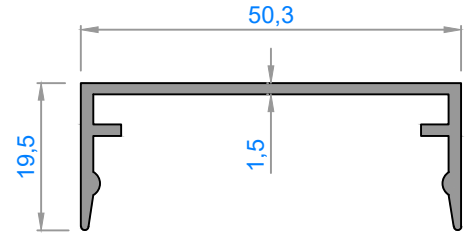
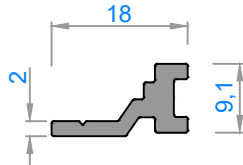
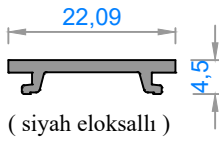
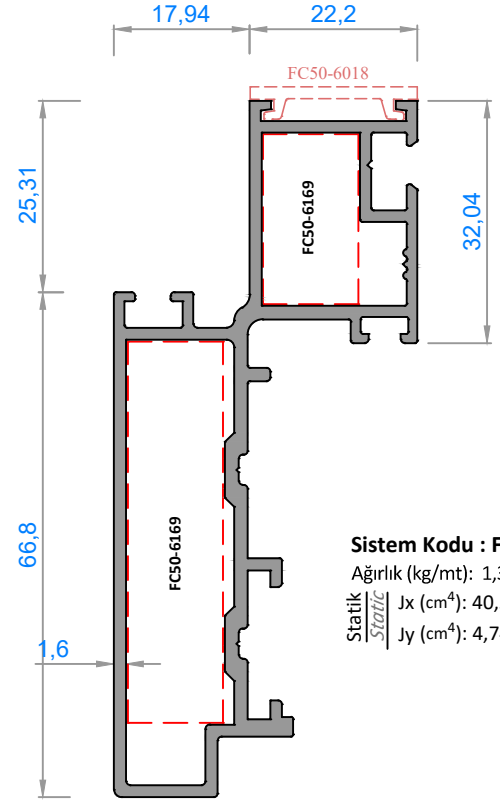
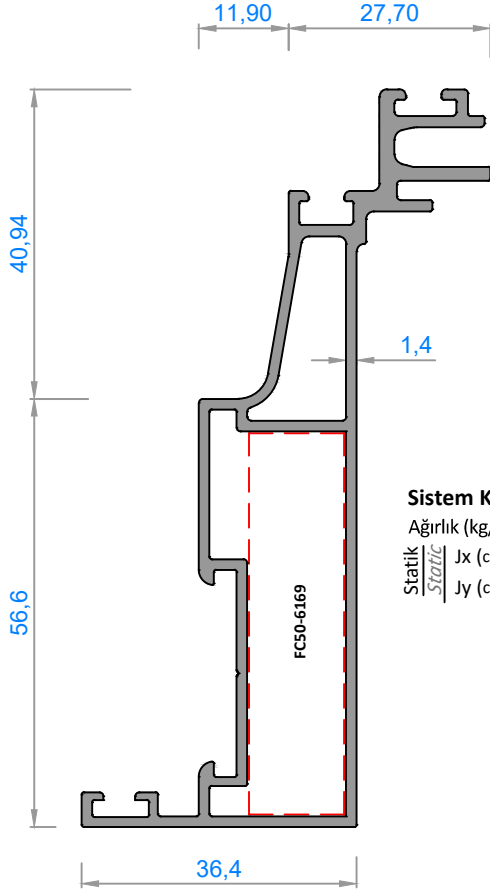

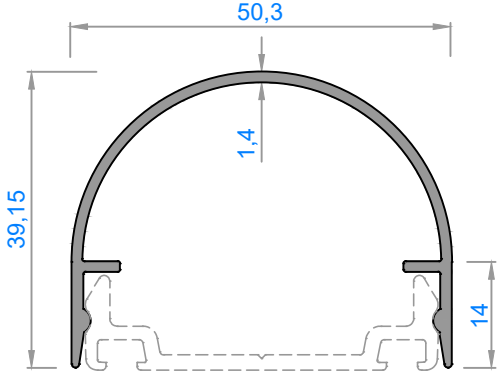

Sistem Kodu : FC50-6023
Ağırlık (kg/mt): 0,450

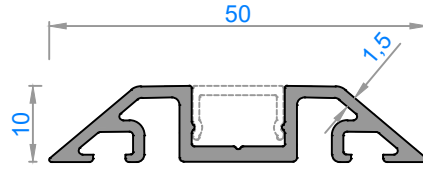

Sistem Kodu : FC50-6041
Ağırlık (kg/mt): 0,413
Statik J_x (cm⁴): 1,50
 J_y (cm⁴): 2,86

(-YATAY TAŞIYICI KAPAK-)

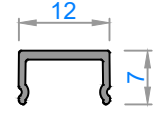

Sistem Kodu : FC50-6025
Ağırlık (kg/mt): 0,280

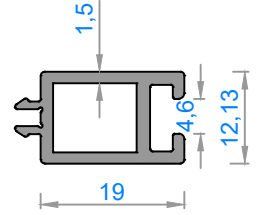

Sistem Kodu : FC50-6026
Ağırlık (kg/mt): 0,315

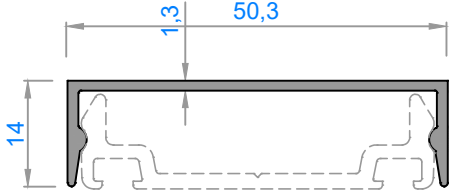

Sistem Kodu : FC50-6024
Ağırlık (kg/mt): 0,285

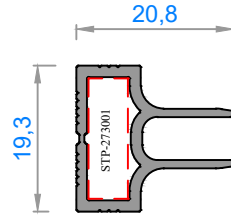

Sistem Kodu : FC50-6027
Ağırlık (kg/mt): 0,265

(siyah eloksallı)

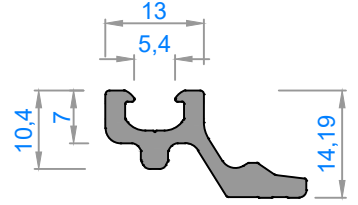

Sistem Kodu : FC50-6028
Ağırlık (kg/mt): 0,145

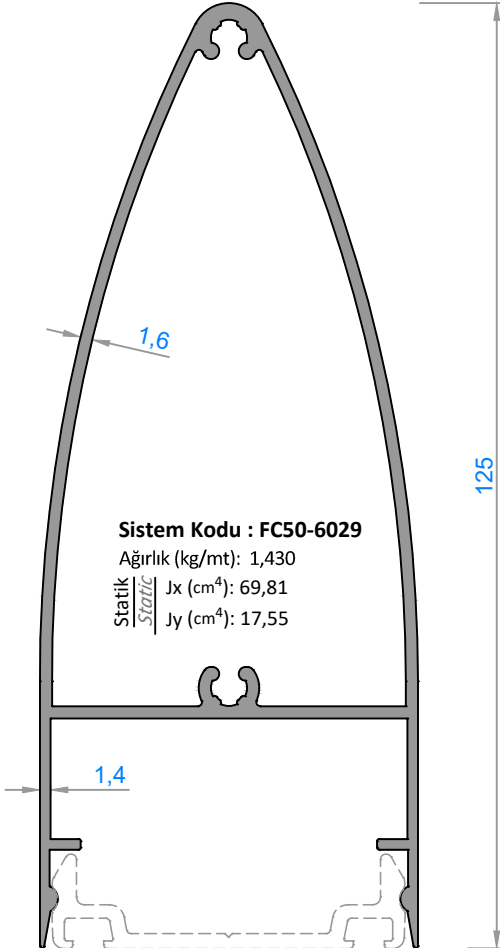

Sistem Kodu : FC50-6029
Ağırlık (kg/mt): 1,430
Statik J_x (cm⁴): 69,81
 J_y (cm⁴): 17,55

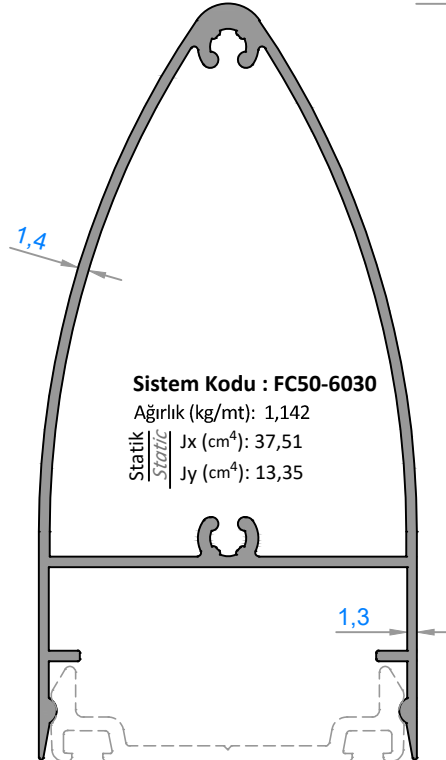

Sistem Kodu : FC50-6030
Ağırlık (kg/mt): 1,142
Statik J_x (cm⁴): 37,51
 J_y (cm⁴): 13,35

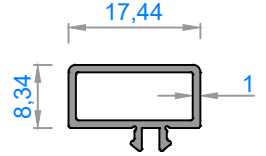

Sistem Kodu : FC50-6028
Ağırlık (kg/mt): 0,145

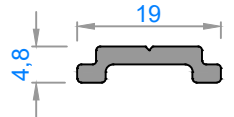

Sistem Kodu : 1328
Ağırlık (kg/mt): 0,145

DILATASYON PROFİL DILATATION PROFILE	DILATASYON BAĞLANTI PROFİLİ PROFİL KODU / PROFILE CODE	DILATATION CONNECTION PROFILE AKSESUAR KODU / ACCESSORY CODE	KESİM ÖLÇÜSÜ CUTTING SIZE
FC50-6000	FC50-6031	FC50-6031-61,8	61,8 mm
FC50-6001	FC50-6031	FC50-6031-81,8	81,8 mm
FC50-6002	FC50-6031	FC50-6031-101,8	101,8 mm
FC50-6003	FC50-6031	FC50-6031-120,8	120,8 mm
FC50-6004	FC50-6031	FC50-6031-138,8	138,8 mm
FC50-6005	FC50-6031	FC50-6031-158,8	158,8 mm
FC50-6006	FC50-6031	FC50-6031-77,3	77,3 mm
FC50-6007	FC50-6031	FC50-6031-97,3	97,3 mm
FC50-6008	FC50-6031	FC50-6031-117,3	117,3 mm
FC50-6009	FC50-6031	FC50-6031-135,8	135,8 mm
FC50-6010	FC50-6031	FC50-6031-154,8	154,8 mm
FC50-6011	FC50-6031	FC50-6031-174,8	174,8 mm

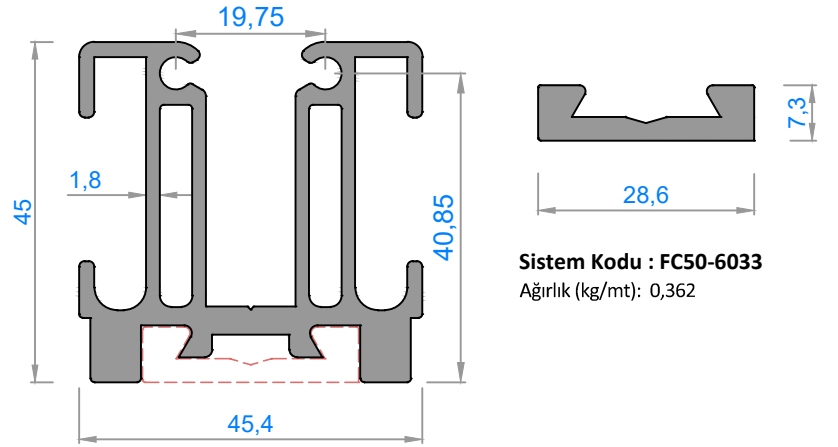
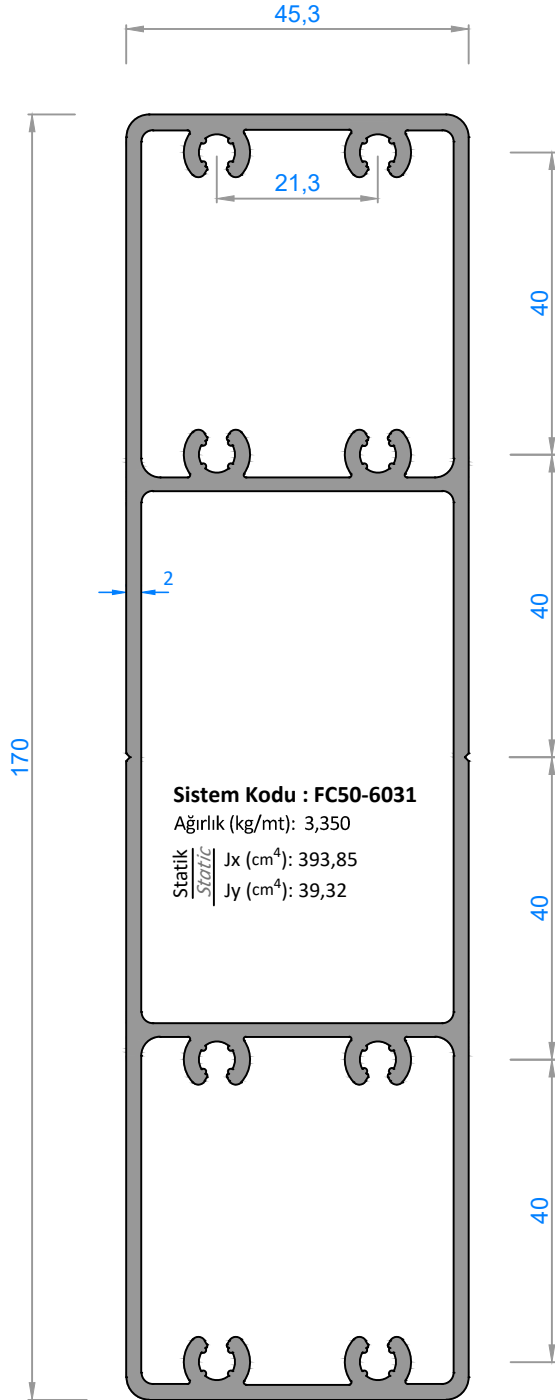

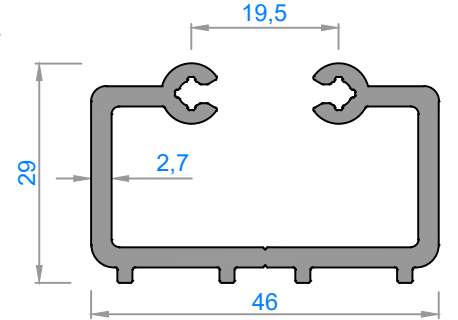

Sistem Kodu : FC50-6032
Ağırlık (kg/mt): 1,670

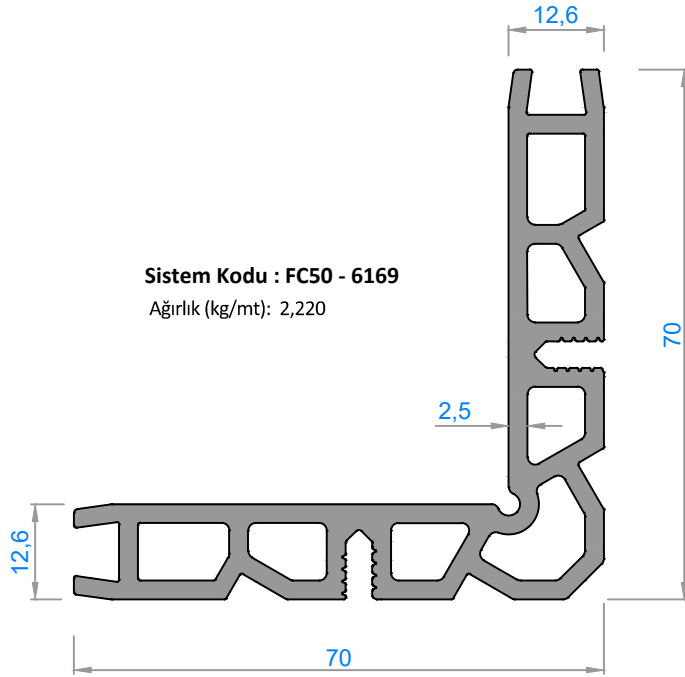

PROFİL PROFILE	"U" BAĞLANTI PROFİLİ PROFİL KODU / PROFILE CODE	"U" CONNECTION PROFILE AKSESUAR KODU / ACCESSORY CODE	KESİM ÖLÇÜSÜ CUTTING SIZE
FC50-6006	(FC50-6032) + (FC50-6033)	(FC50-6032) + (FC50-6033) - 77,3	77,3 mm
FC50-6007	(FC50-6032) + (FC50-6033)	(FC50-6032) + (FC50-6033) - 97,3	97,3 mm
FC50-6008	(FC50-6032) + (FC50-6033)	(FC50-6032) + (FC50-6033) - 117,3	117,3 mm
FC50-6009	(FC50-6032) + (FC50-6033)	(FC50-6032) + (FC50-6033) - 135,8	135,8 mm
FC50-6010	(FC50-6032) + (FC50-6033)	(FC50-6032) + (FC50-6033) - 154,8	154,8 mm
FC50-6011	(FC50-6032) + (FC50-6033)	(FC50-6032) + (FC50-6033) - 174,8	174,8 mm

PROFİL PROFILE	"U" BAĞLANTI PROFİLİ PROFİL KODU / PROFILE CODE	"U" CONNECTION PROFILE AKSESUAR KODU / ACCESSORY CODE	KESİM ÖLÇÜSÜ CUTTING SIZE
FC50-6006	FC50-4803	(FC50-4803) - 77,3	77,3 mm
FC50-6007	FC50-4803	(FC50-4803) - 97,3	97,3 mm
FC50-6008	FC50-4803	(FC50-4803) - 117,3	117,3 mm
FC50-6009	FC50-4803	(FC50-4803) - 135,8	135,8 mm
FC50-6010	FC50-4803	(FC50-4803) - 154,8	154,8 mm
FC50-6011	FC50-4803	(FC50-4803) - 174,8	174,8 mm



KÖŞE TAKOZLARI (CORNER CLEATS)			
Nr	 L m	 AKS. KODU ACS. CODE	KESİM ÖLÇÜSÜ CUTTING SIZE
FC50-6012	FC50-6019	FC50-6019-25,0	25,0 mm
	FC50-6019	FC50-6019-25,0	25,0 mm
FC50-6014	FC50-6019	FC50-6019-6,50	6,50 mm
	FC50-6019	FC50-6019-8,90	8,90 mm
	FC50-6019	FC50-6019-25,0	25,0 mm
FC50-6016	FC50-6019	FC50-6019-50,4	50,4 mm
FC50-6017	FC50-6019	FC50-6019-22,5	22,3 mm
	FC50-6019	FC50-6019-50,4	31,4 mm
FC50-6020	FC50-6019	FC50-6019-9,80	9,80 mm
FC50-6021	FC50-6019	FC50-6019-21,95	21,95 mm

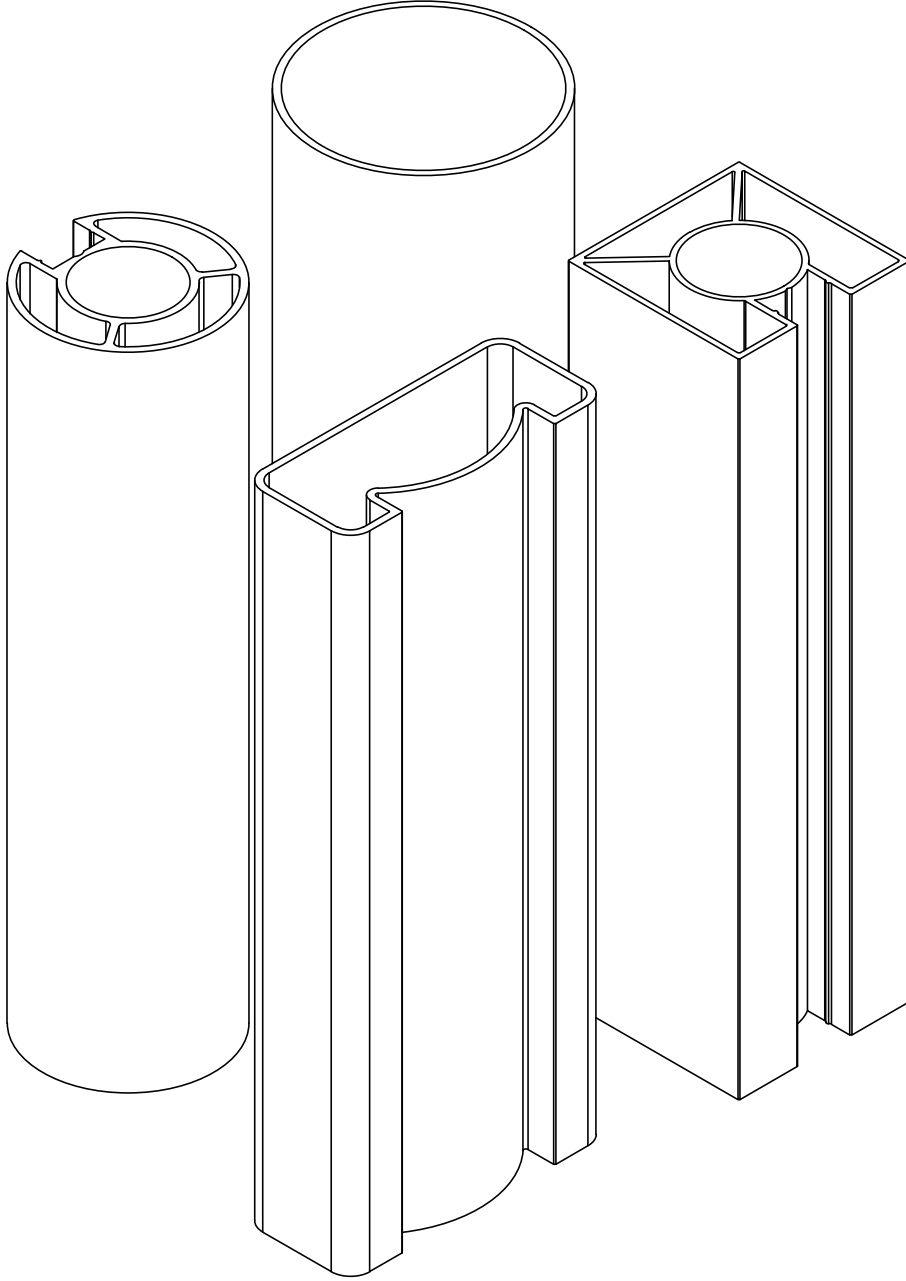

KÜPEŞTE PROFİLLERİ / Handrail Profiles

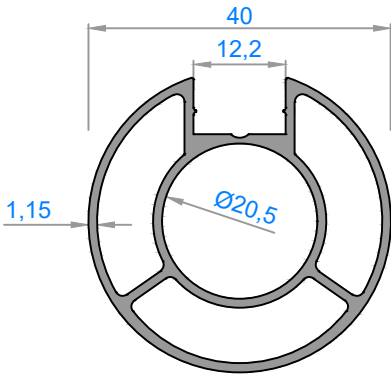

2385 - 0,711 kg/m

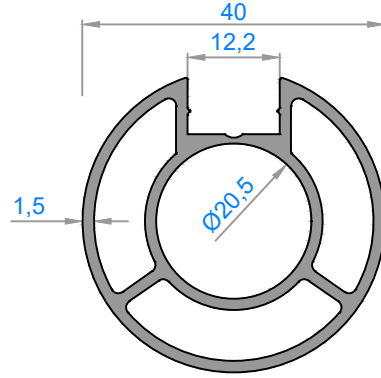

5033 - 0,856 kg/m

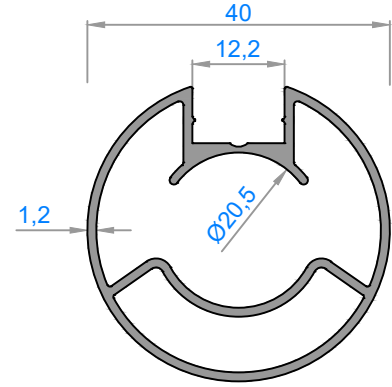

4915 - 0,630 kg/m

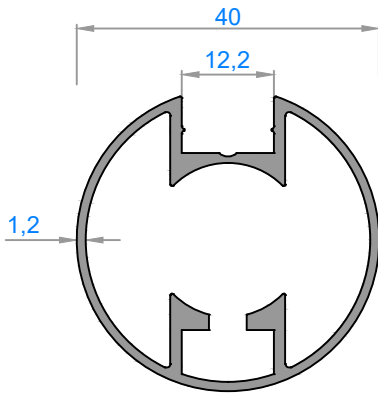

2384 - 0,640 kg/m

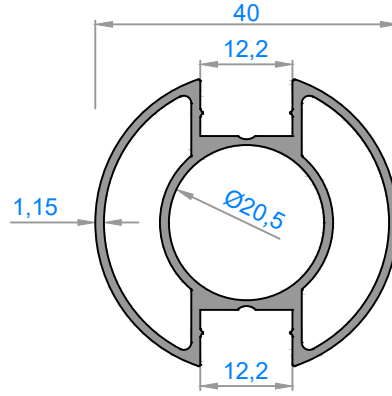

2391 - 0,677 kg/m

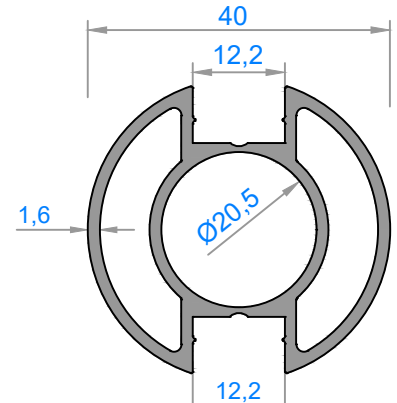

4279 - 0,854 kg/m

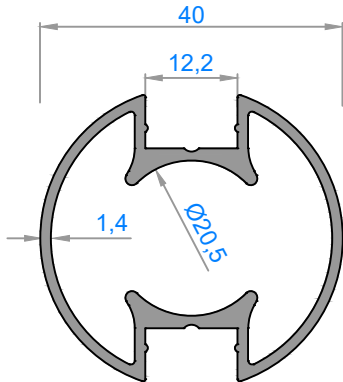

1869 - 0,697 kg/m

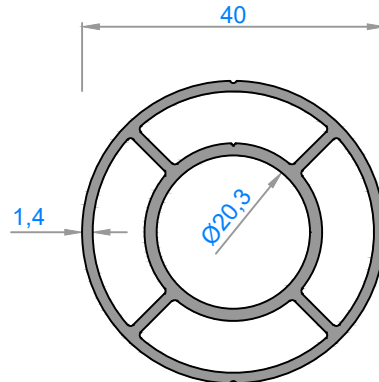

4919 - 0,862 kg/m

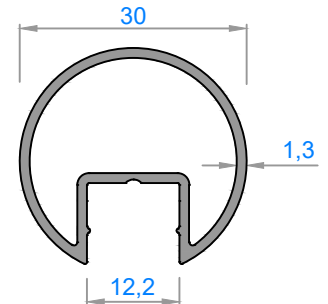

3580 - 0,387 kg/m

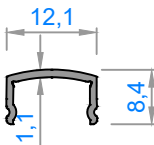

1171 - 0,075 kg/m

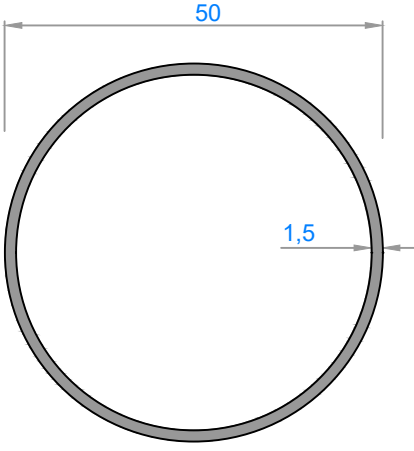

1019 - 0,616 kg/m

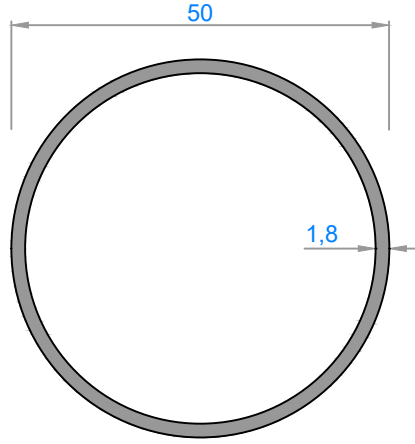

3252 - 0,739 kg/m

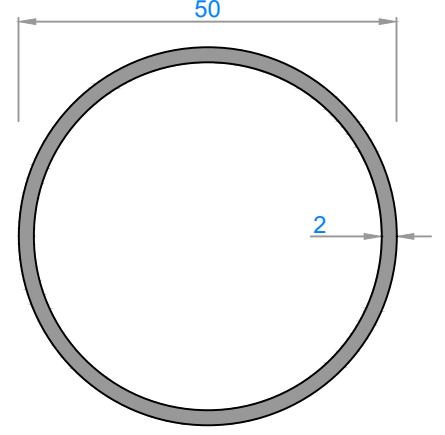

1007 - 0,819 kg/m

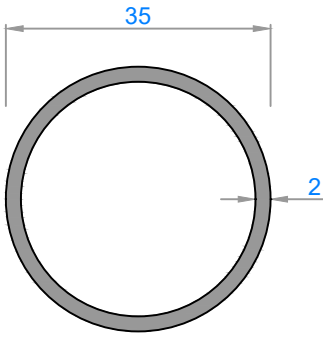

1446 - 0,564 kg/m

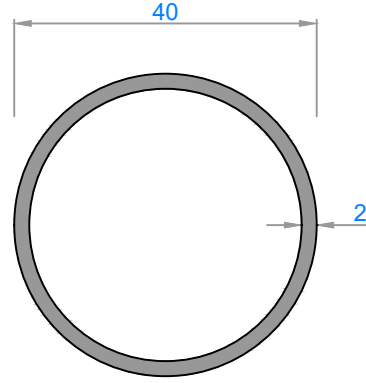

2190 - 0,648kg/m

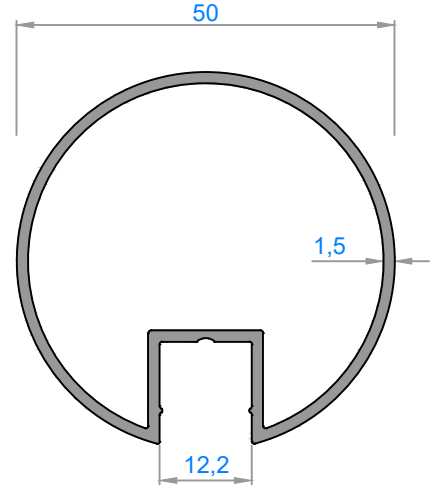

3761 - 0,726 kg/m

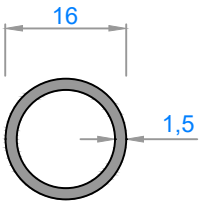

2674 - 0,187 kg/m

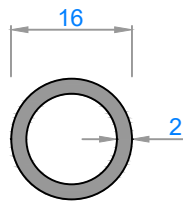

1484 - 0,238kg/m

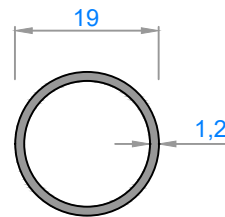

1654 - 0,185 kg/m

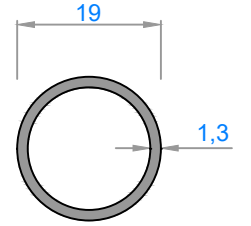

2140 - 0,196kg/m

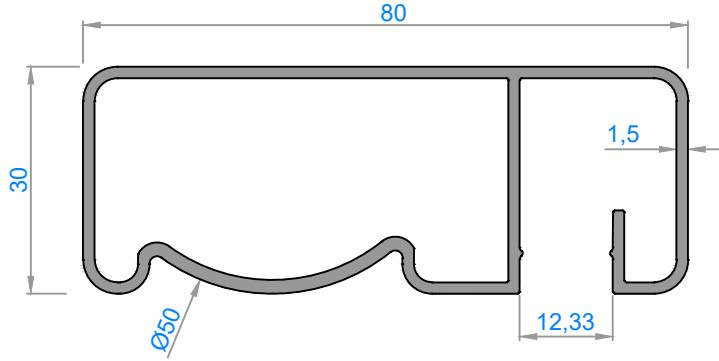

3816 - 0,979 kg/m

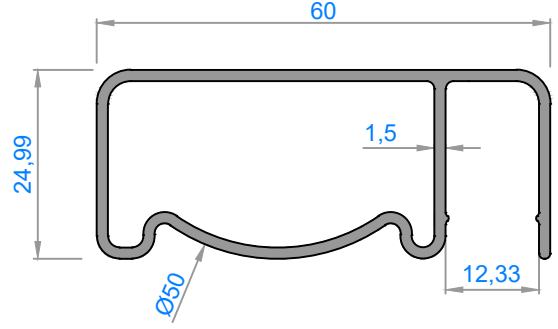

4003 - 0,720 kg/m

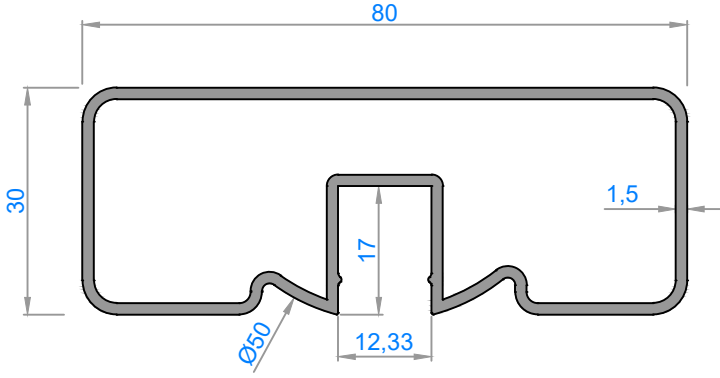

3815 - 1,012 kg/m

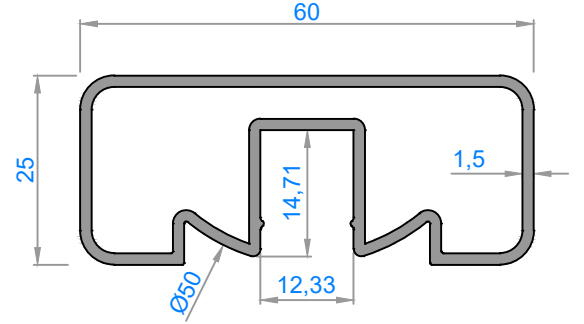

3955 - 0,810 kg/m

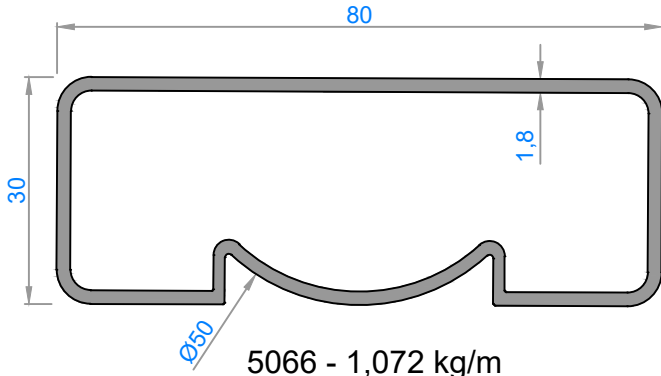

5066 - 1,072 kg/m

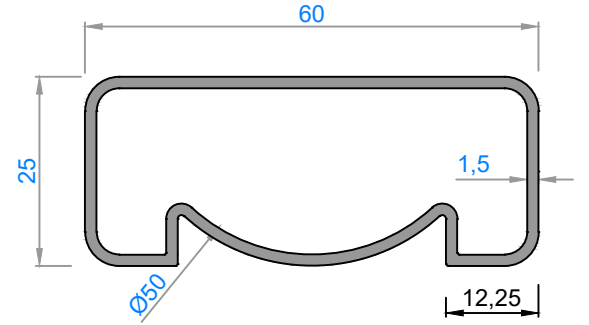

3561 - 0,704 kg/m

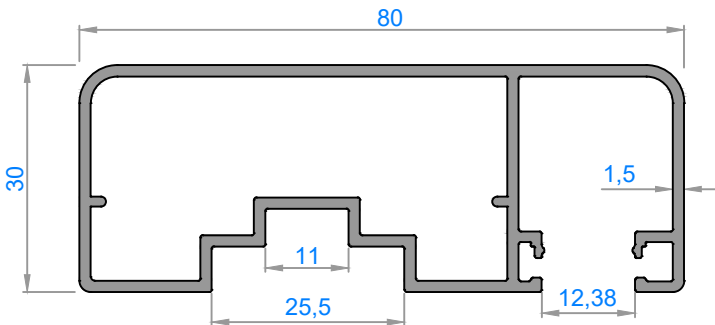

* 4338 - 1,060 kg/m

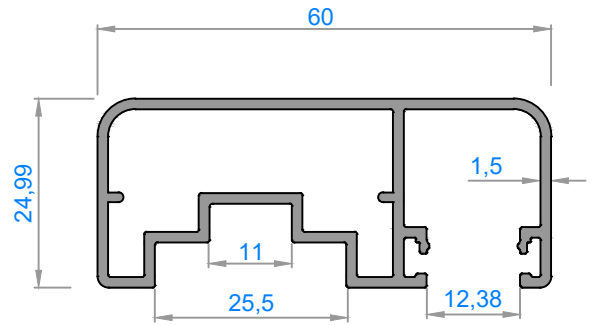

* 4339 - 0,781 kg/m

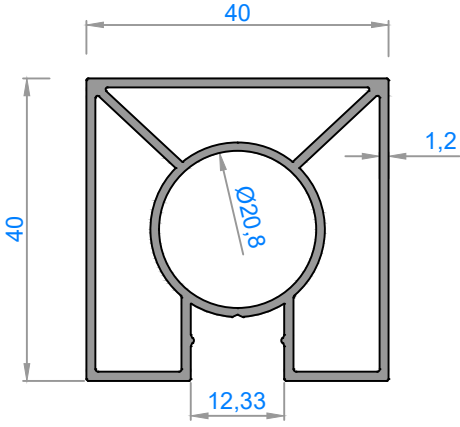

3818 - 0,874 kg/m

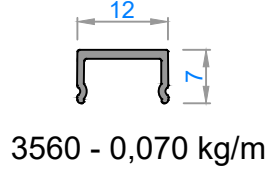

3560 - 0,070 kg/m

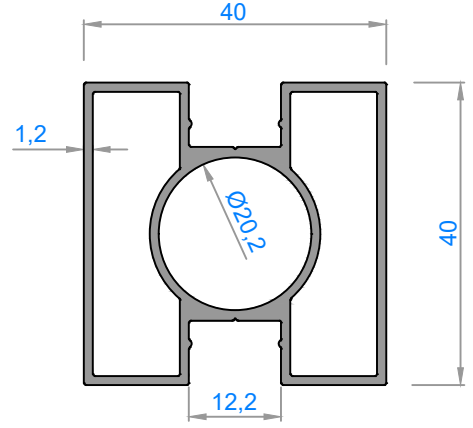

* 3562 - 0,824 kg/m

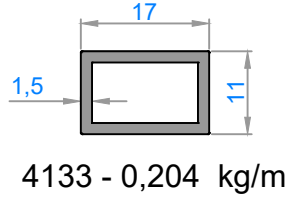

4133 - 0,204 kg/m

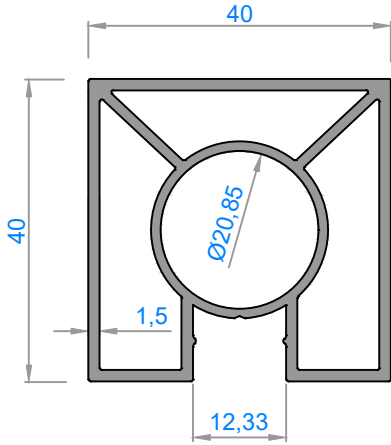

* 4376 - 0,985 kg/m

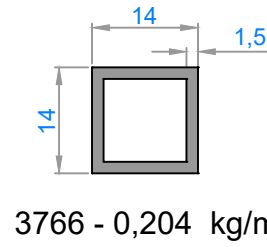

3766 - 0,204 kg/m

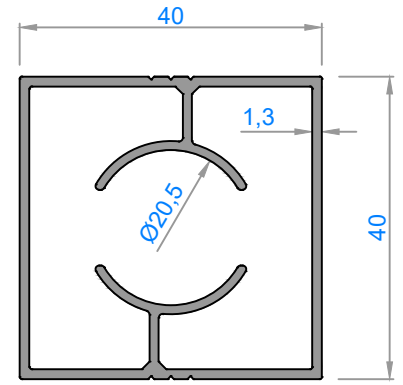

* 4680 - 0,749 kg/m

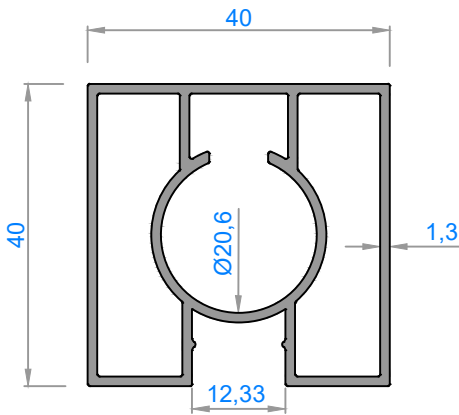

* 3765 - 0,855 kg/m

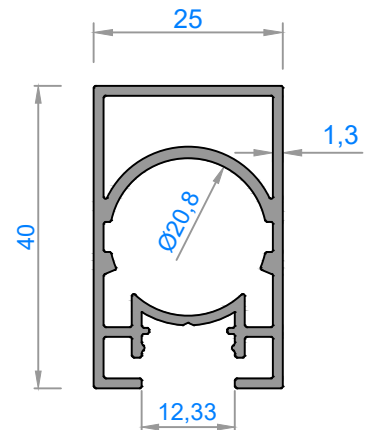

4460 - 0,674 kg/m

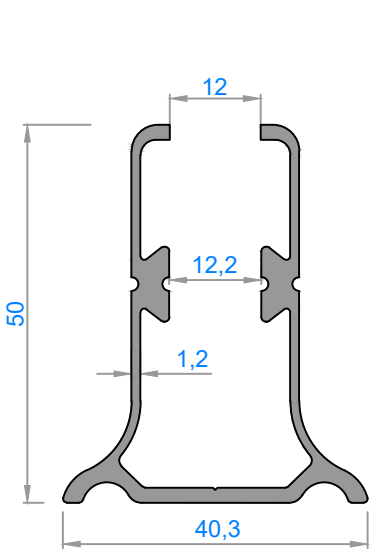

3890 - 0,750 kg/m

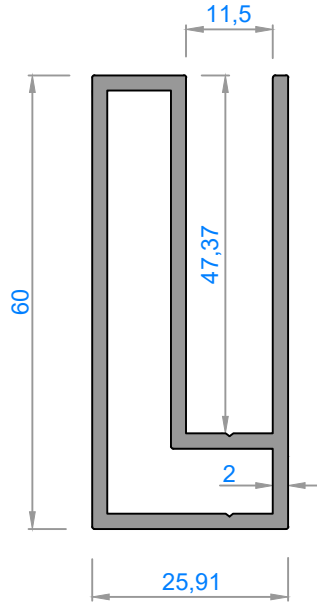

* 4011 - 1,150 kg/m

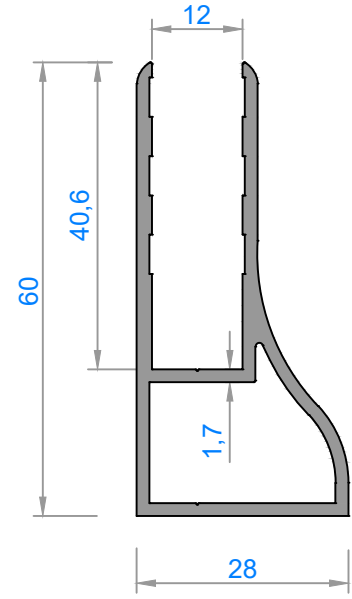

4266 - 0,815 kg/m

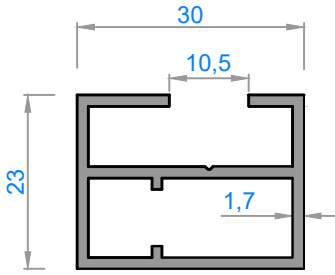

* 3764 - 0,542 kg/m

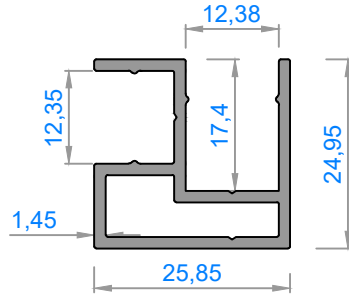

3814 - 0,436 kg/m

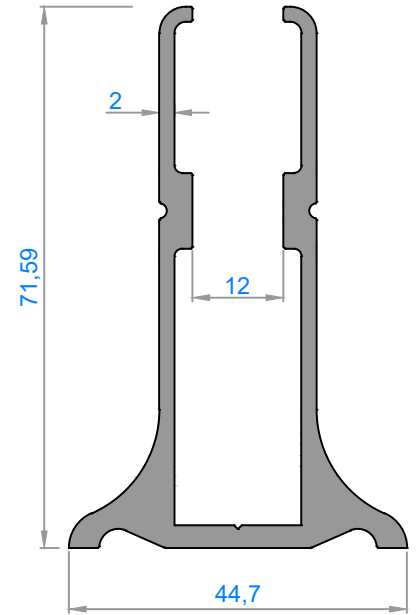

3762 - 1,440 kg/m

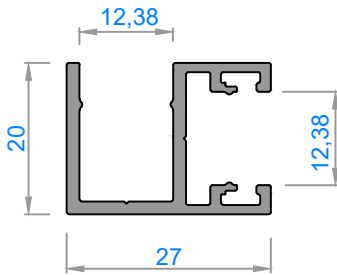

* 4337 - 0,370 kg/m

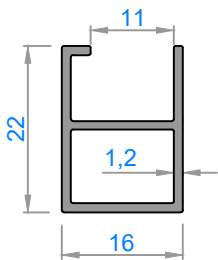

* 4128 - 0,236 kg/m

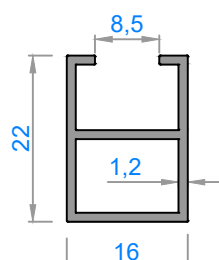

4129 - 0,248 kg/m

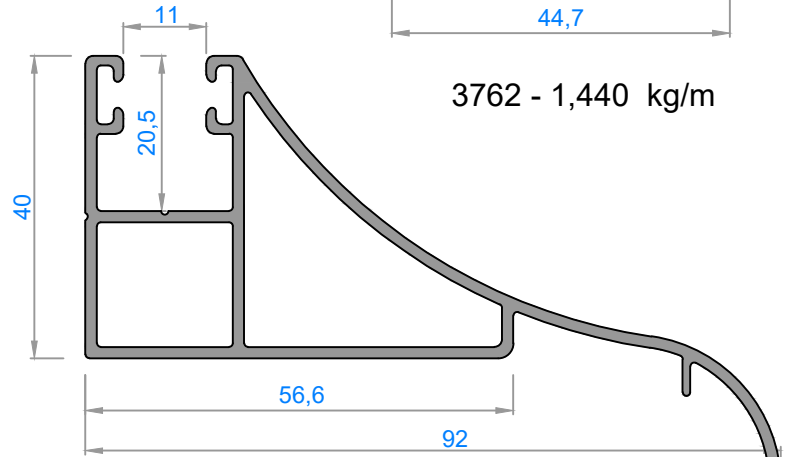

4767 - 1,112 kg/m

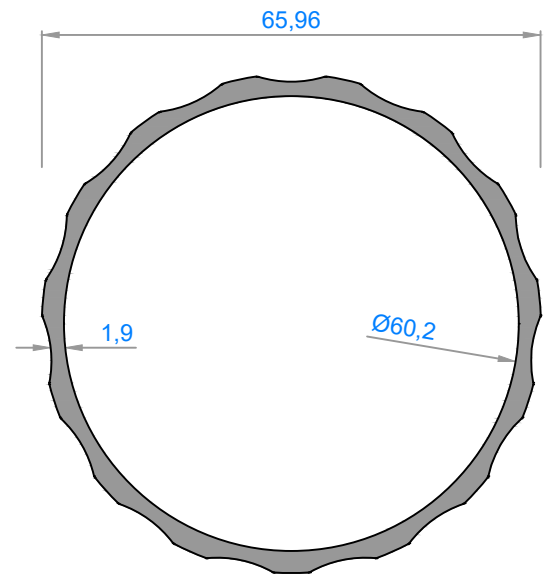
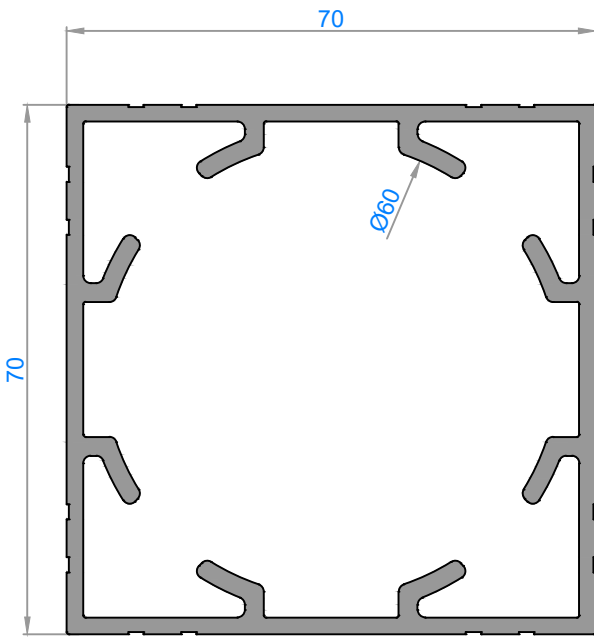
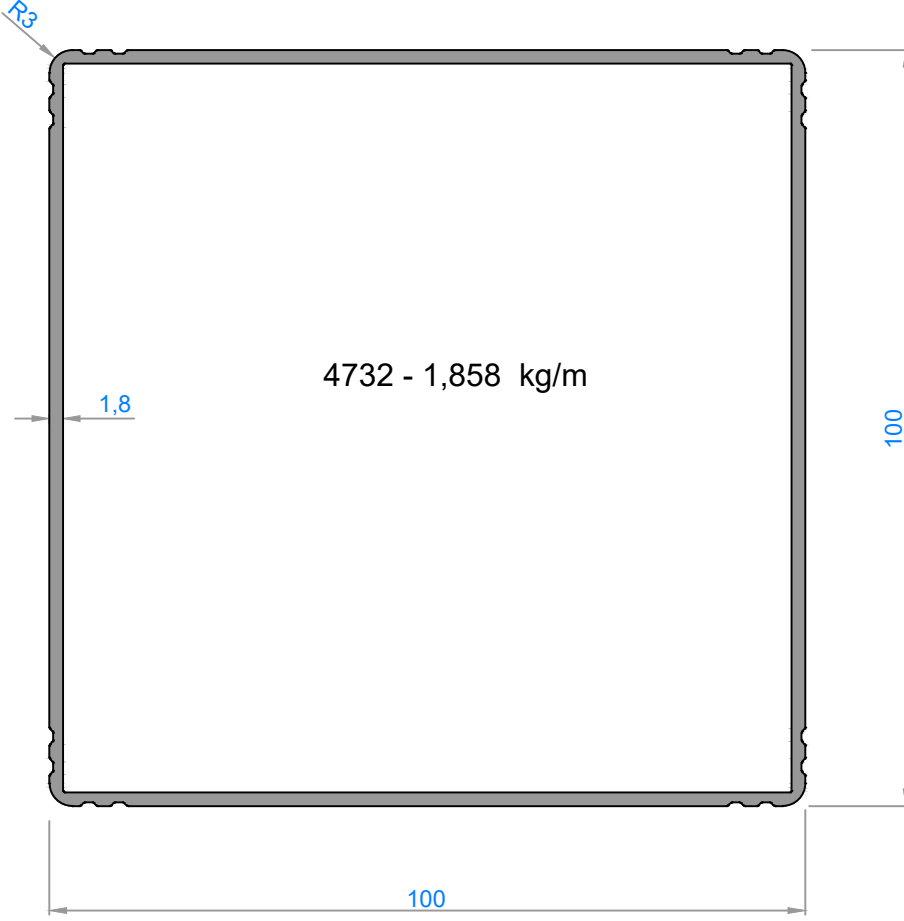

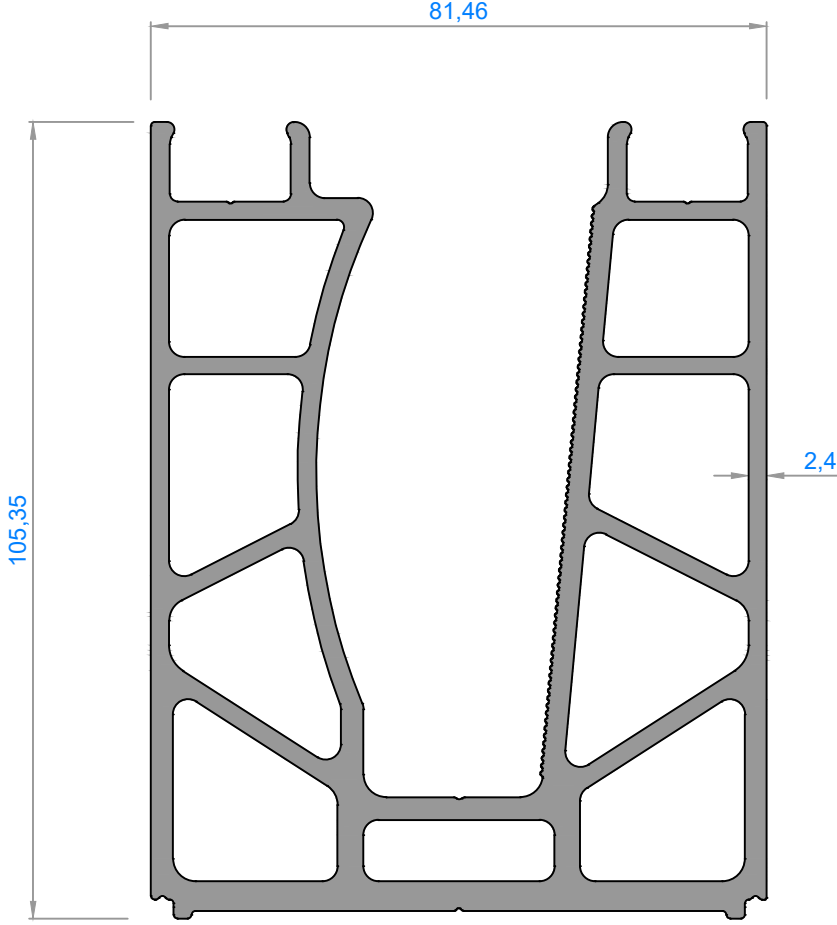

4800 - 5,322 kg/m

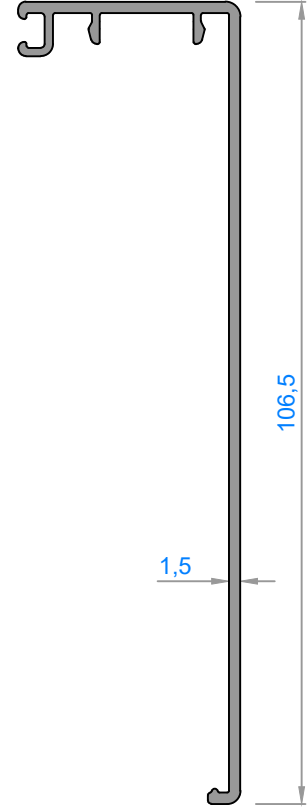

4801 - 0,607 kg/m



PVC SIKIŞTIRMA SETİ



EPDM CONTA

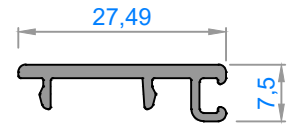

4802 - 0,188 kg/m

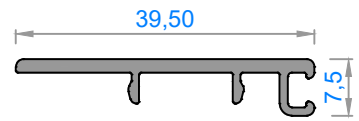

5456 - 0,250 kg/m

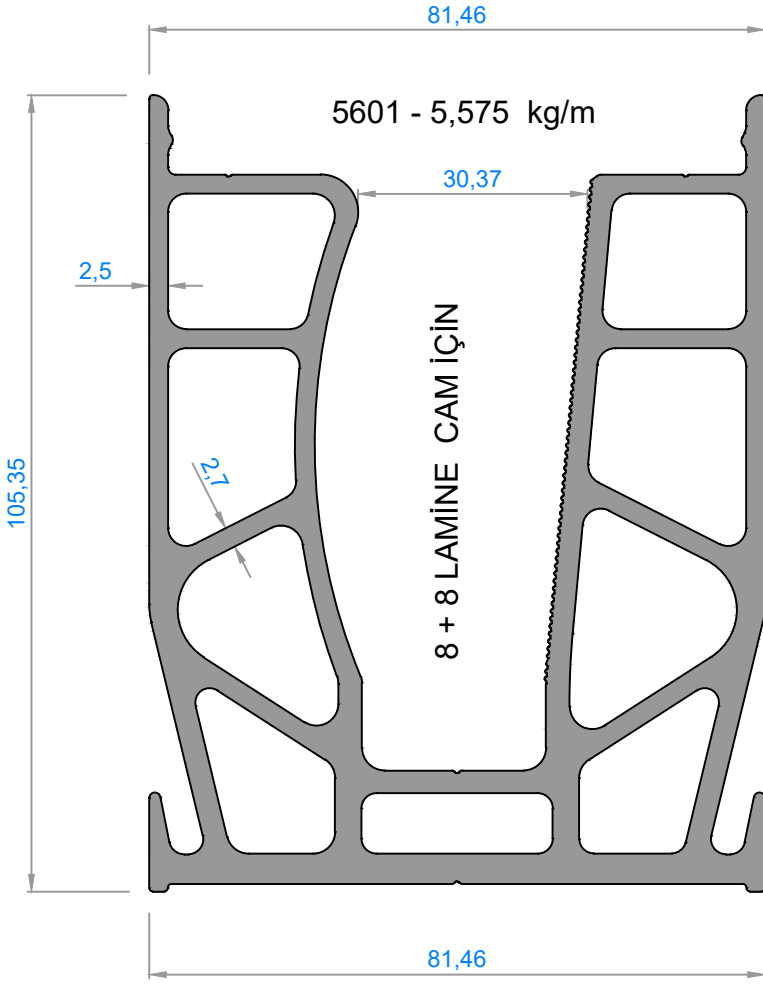

TEK KAPAK SİSTEMİ

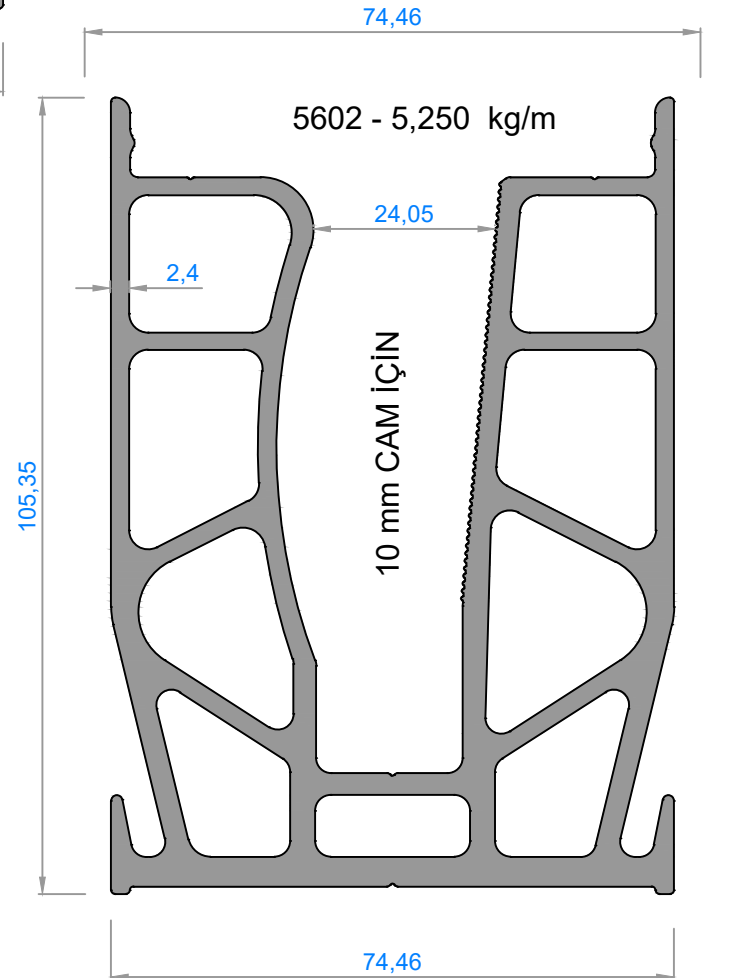
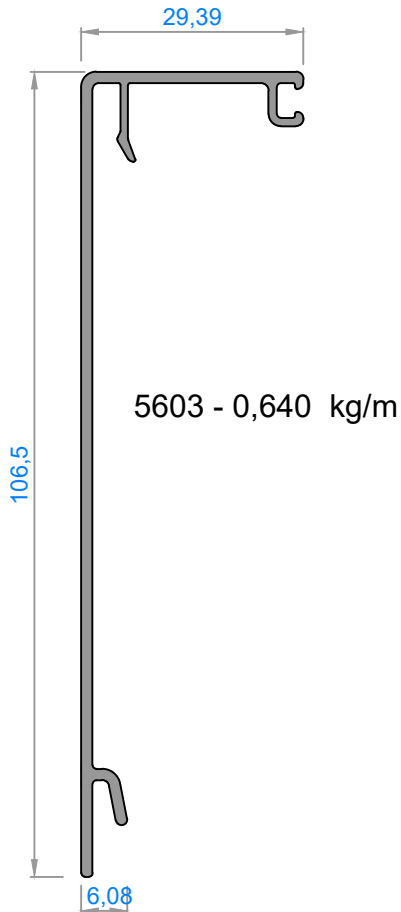
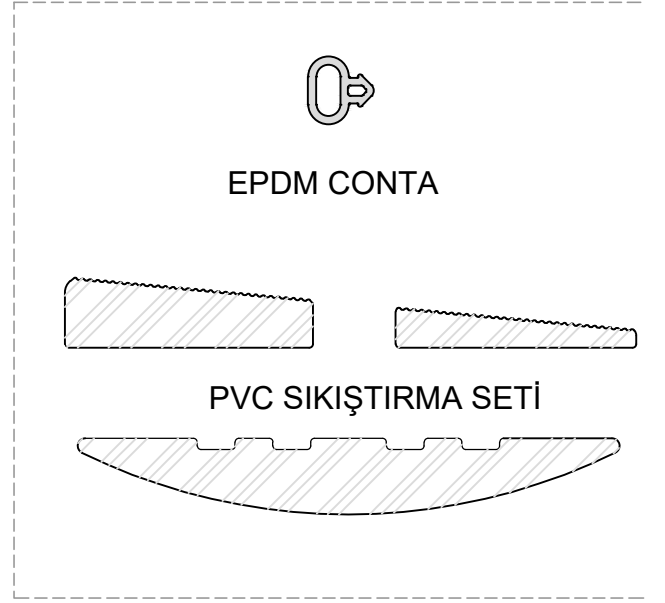

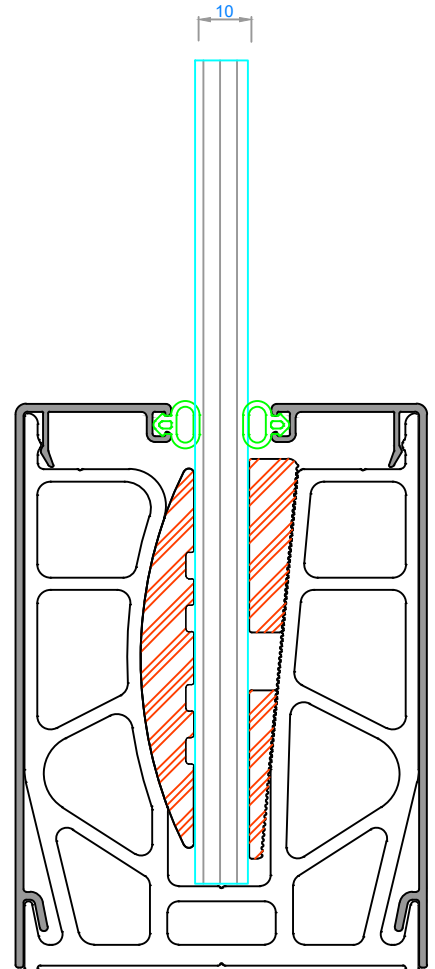
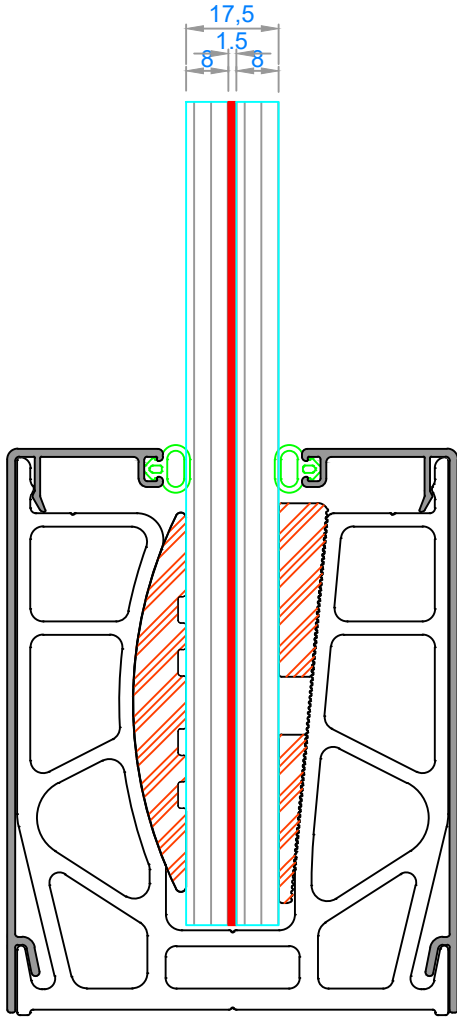

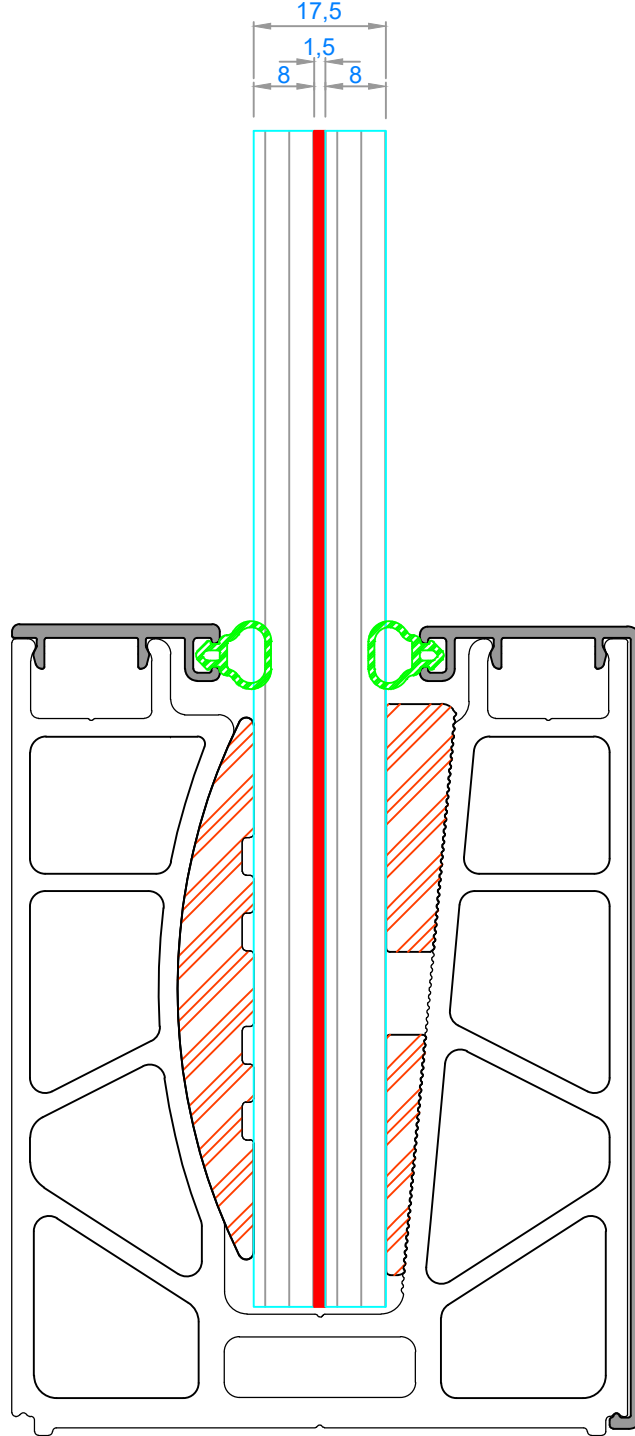

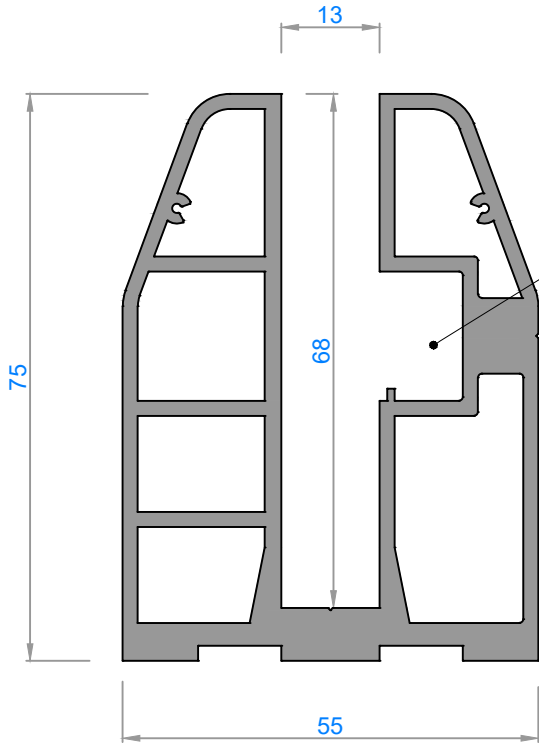

3929 - 2,971 kg/m

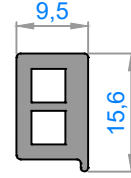
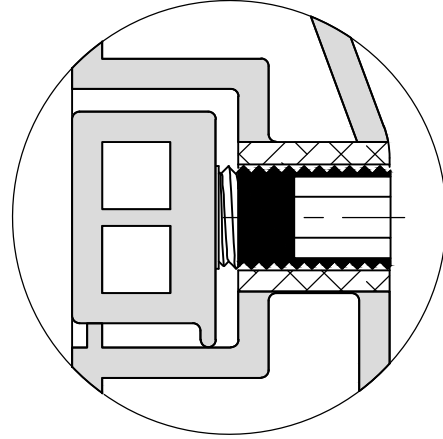

3928 - 0,255 kg/m

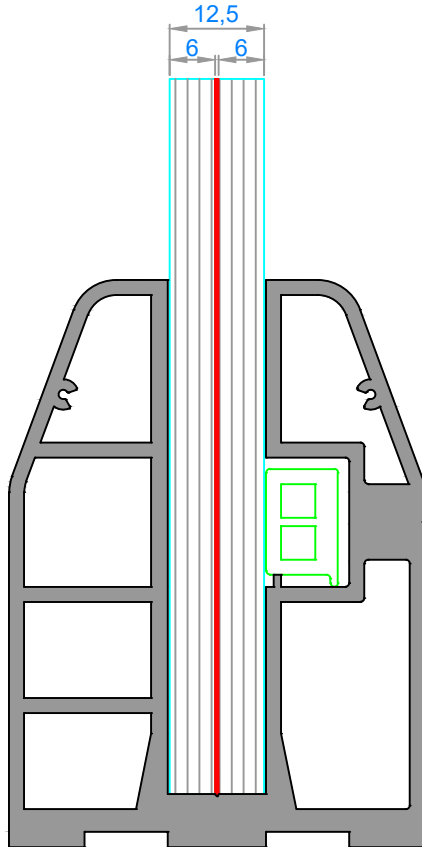

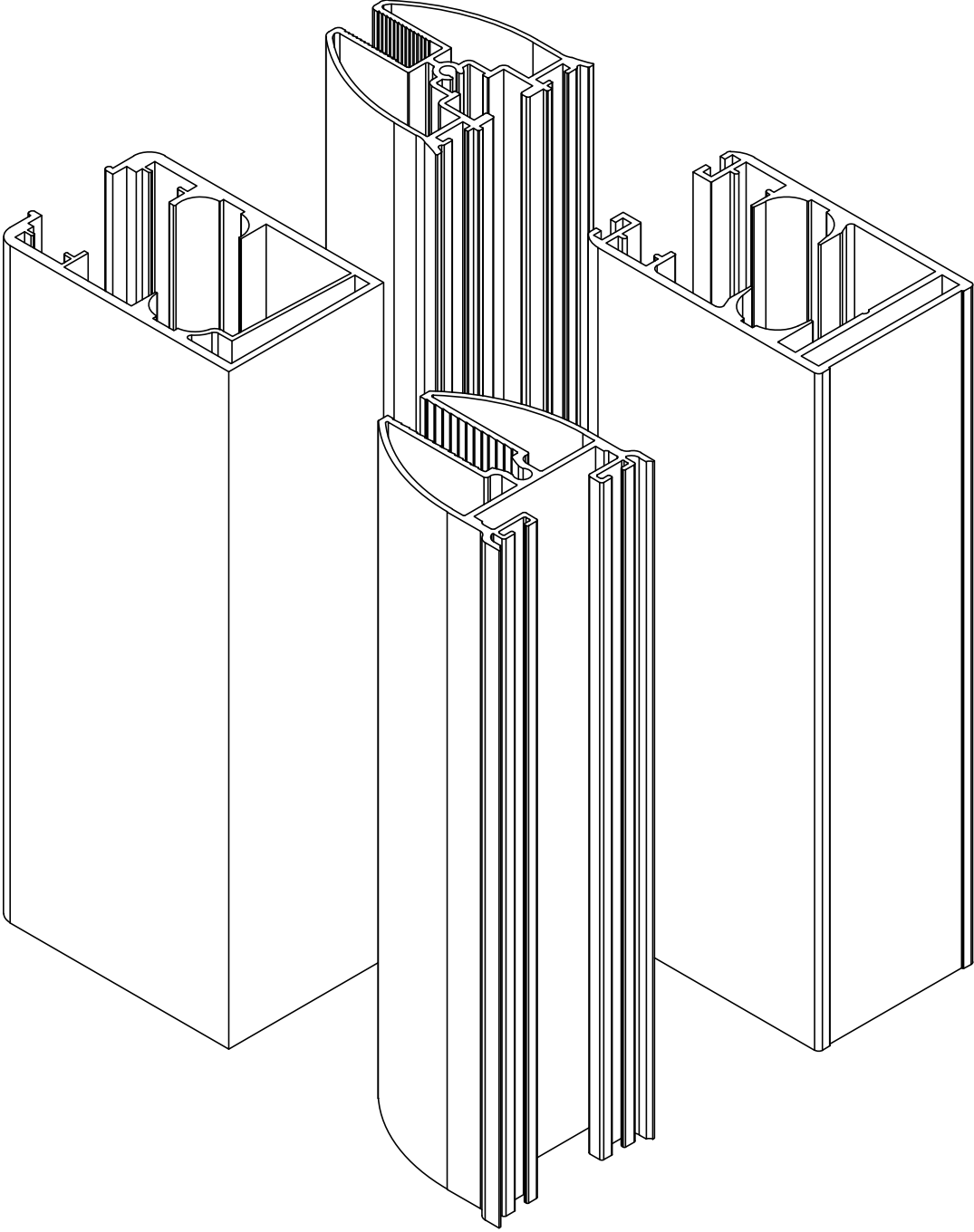

CAM BALKON PROFİLLERİ / Glass Balcony Profiles

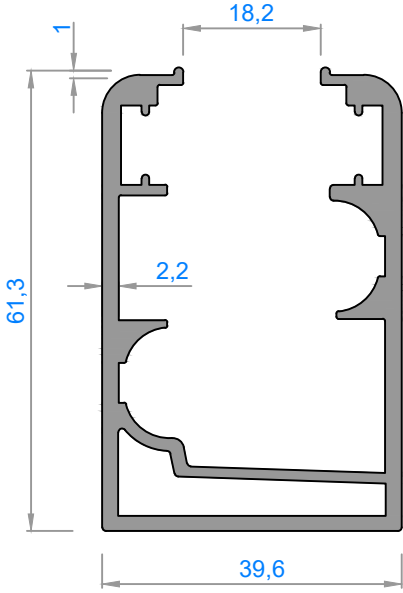

3856 - 1,400 kg/m

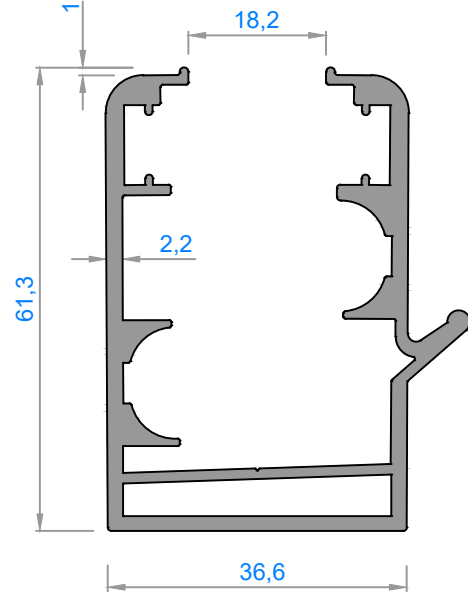

4067 - 1,450 kg/m

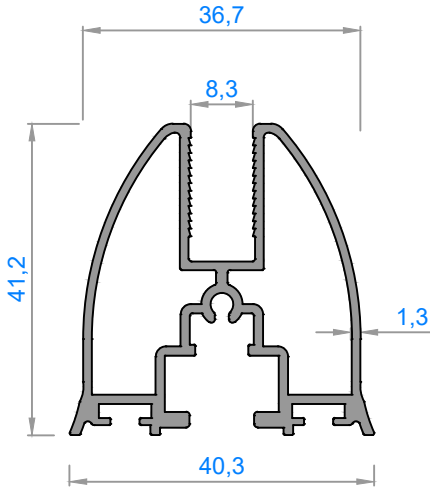

3857 - 0,780 kg/m

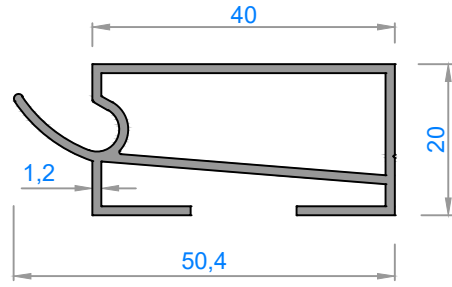

4392 - 0,504 kg/m

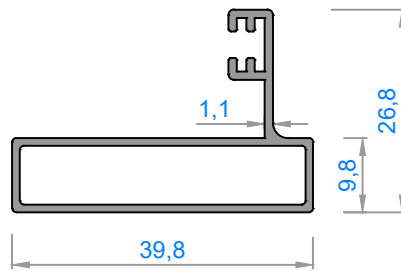

3858 - 0,408 kg/m

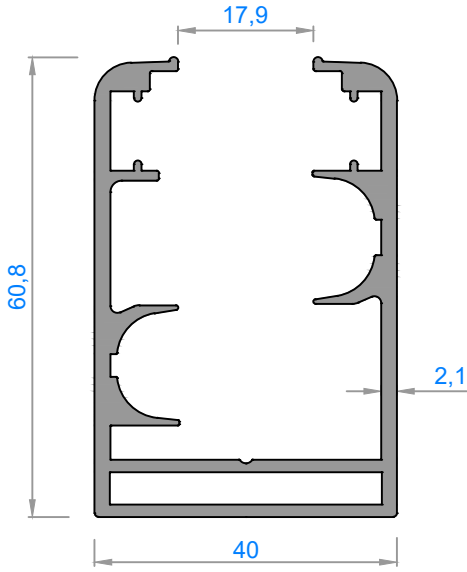

*4118 - 1,357 kg/m

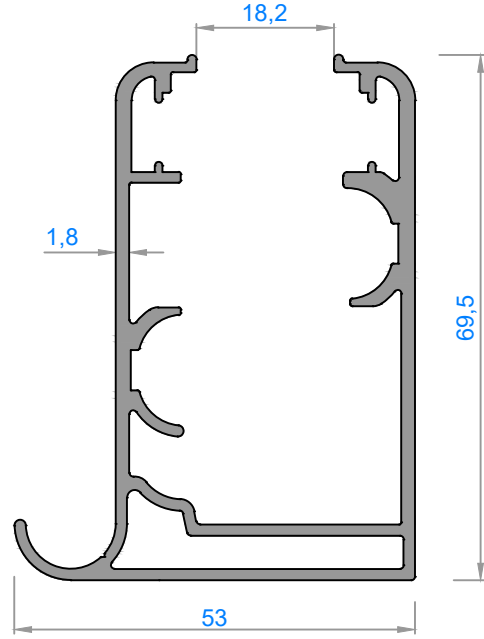

4386 - 1,397 kg/m

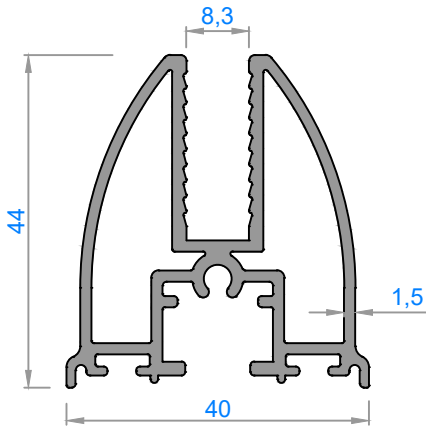

5715 - 1,016 kg/m

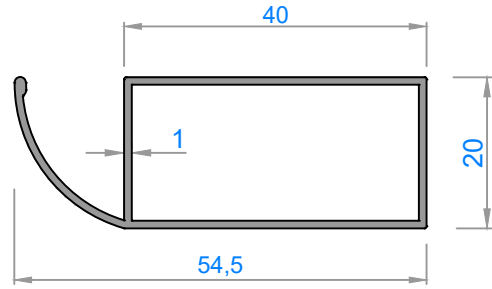

3127 - 0,388 kg/m

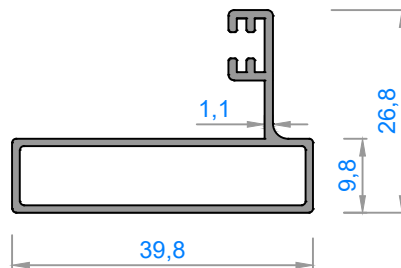

3858 - 0,408 kg/m

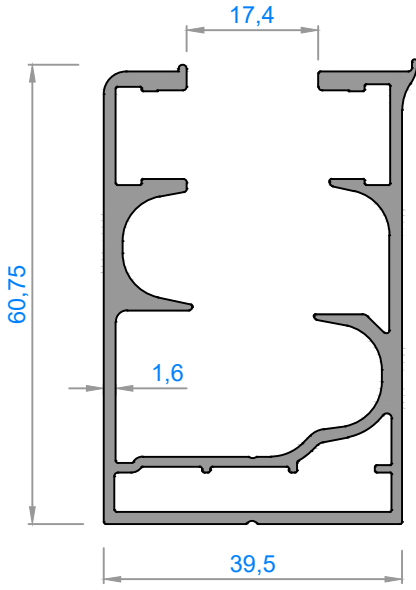

4776 - 1,238 kg/m

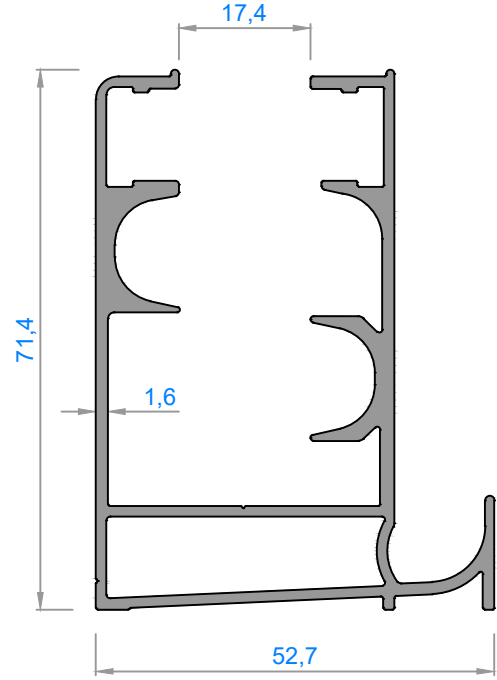

4777 - 1,410 kg/m

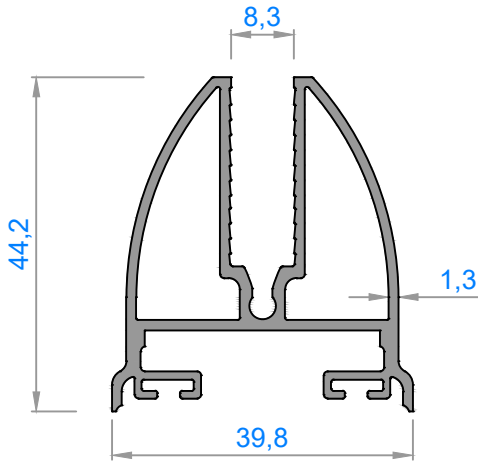

4778 - 0,850 kg/m

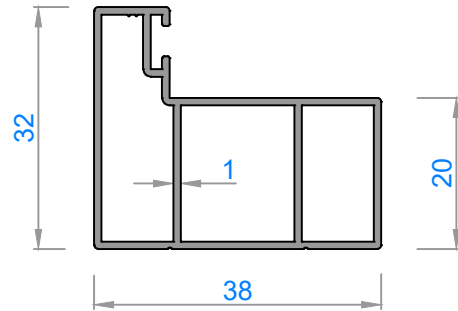

4389 - 0,480 kg/m

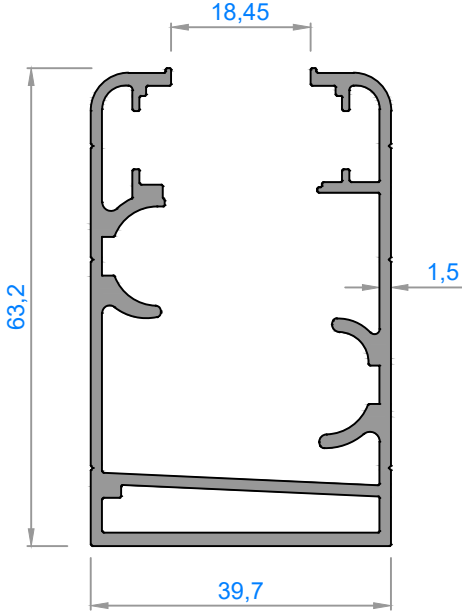

5207 - 1,200 kg/m

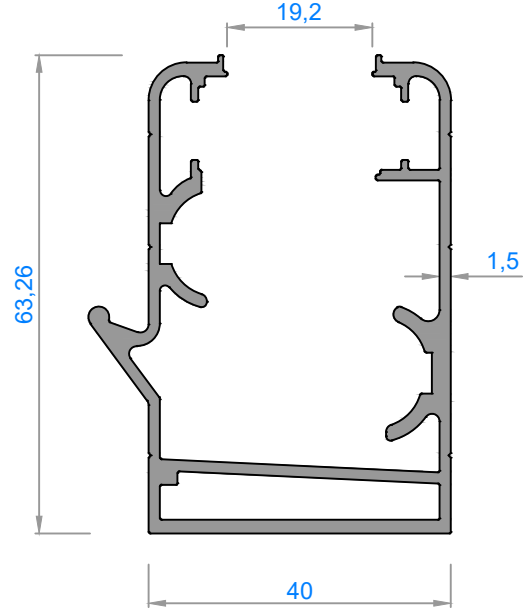

5208 - 1,250 kg/m

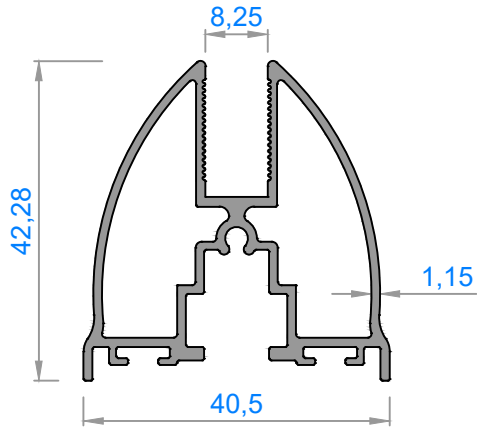

5209 - 0,736 kg/m

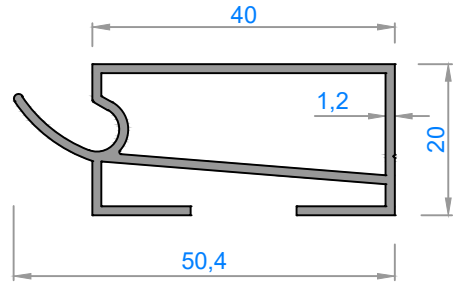

4392 - 0,504 kg/m

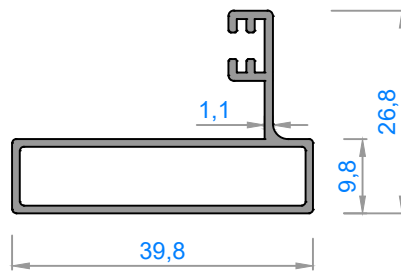

3858 - 0,408 kg/m

ALTERNATİF KASALAR VE KANATLAR

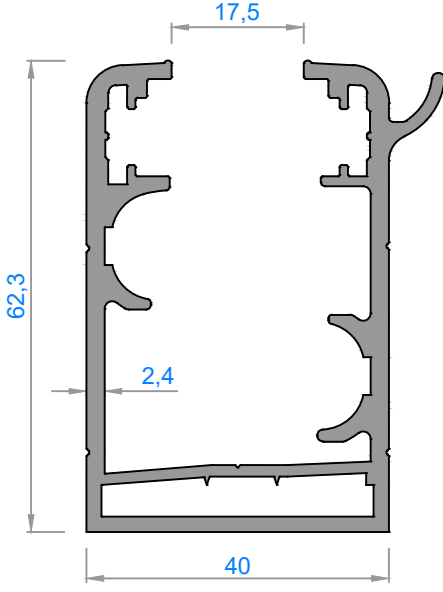

4689 - 1,575 kg/m

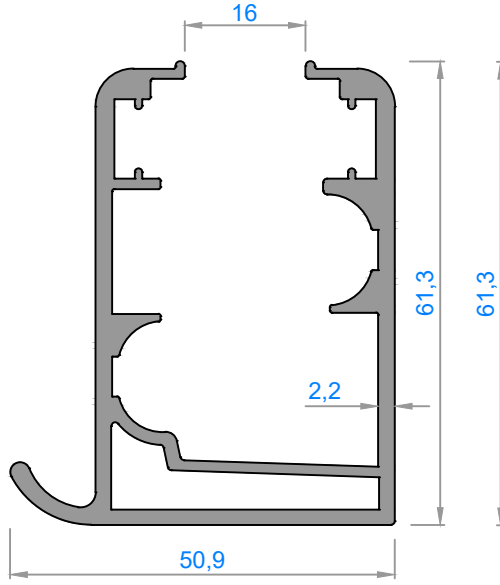

5297 - 1,496 kg/m

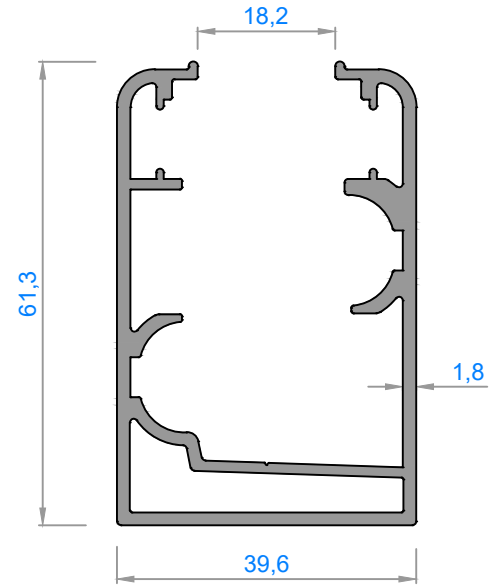

4910 - 1,210 kg/m

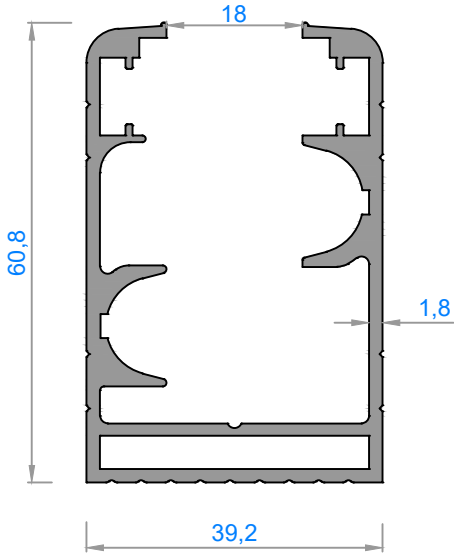

5789 - 1,338 kg/m

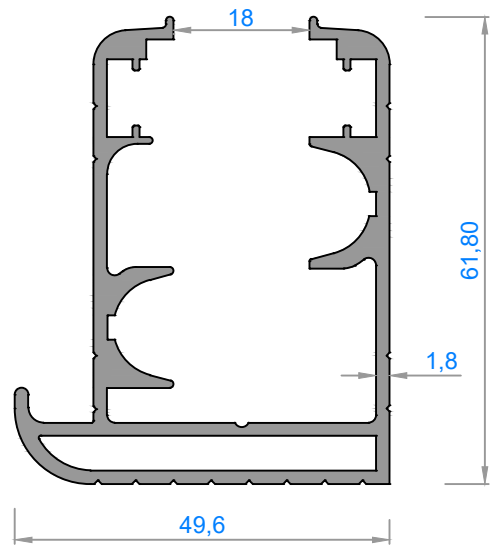

5790 - 1,460 kg/m

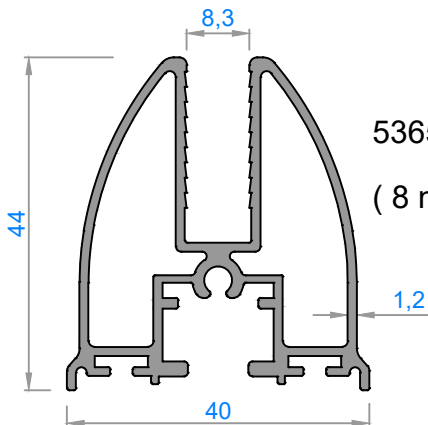

5365 - 0,860 kg/m
(8 mm İnce Firtına)

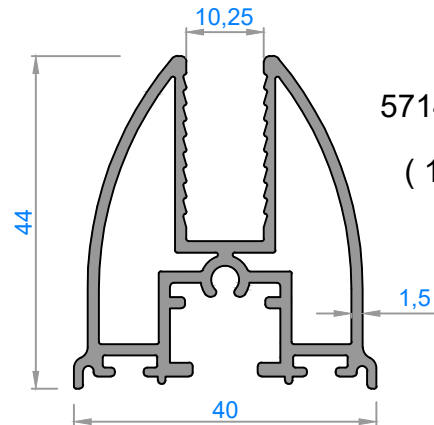

5714 - 0,954 kg/m
(10 mm Firtına)

ISICAMLI SERİ 1

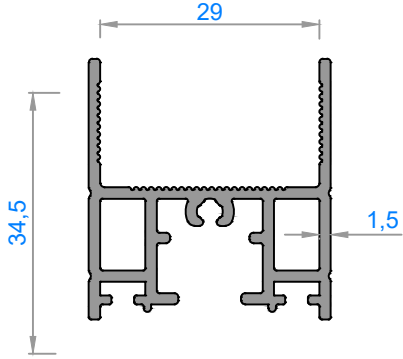

5792 - 0,635 kg/m

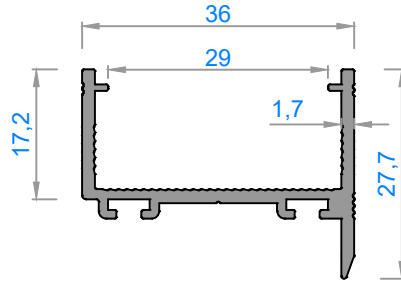

5784 - 0,390 kg/m

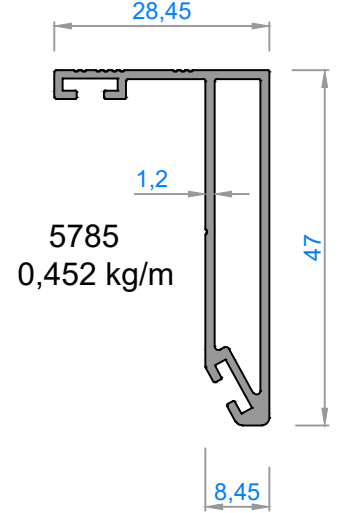

5785
0,452 kg/m

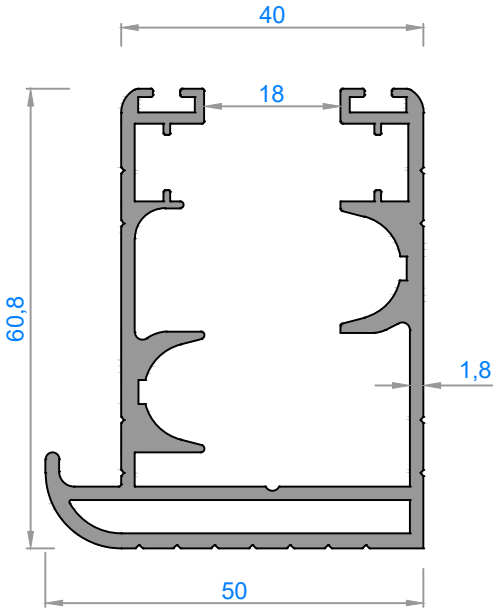

5787 - 1,540 kg/m

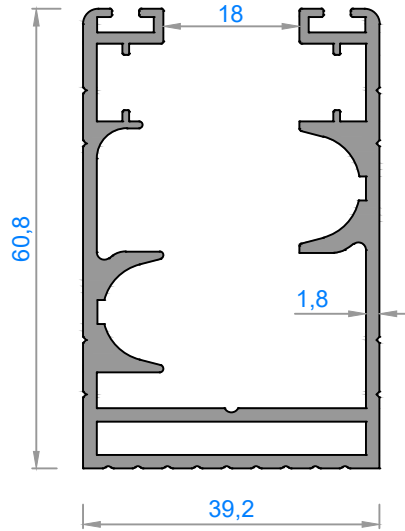

5788 - 1,360 kg/m

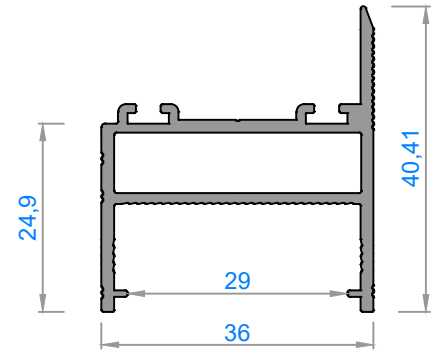

5791 - 0,595 kg/m

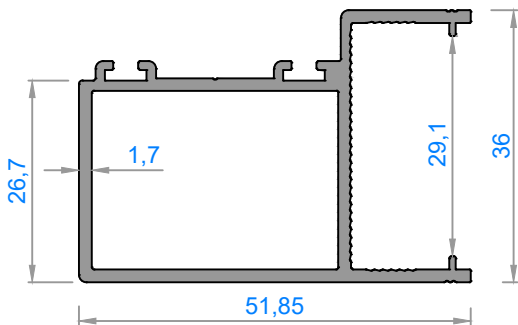

5786 - 0,757 kg/m

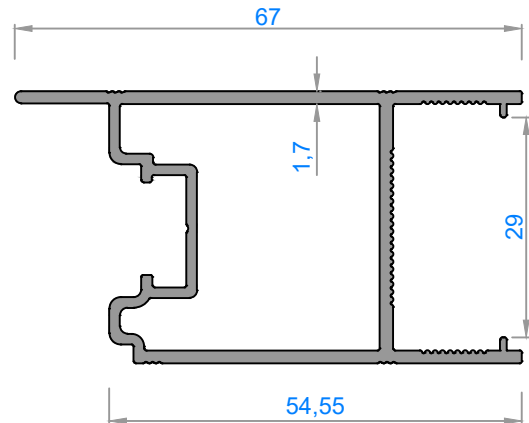

5793 - 0,905 kg/m

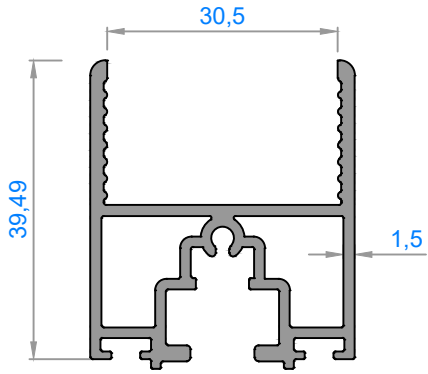

5068 - 0,825 kg/m

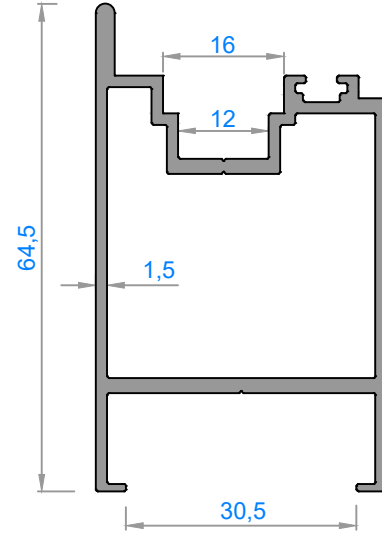

4821 - 0,988 kg/m

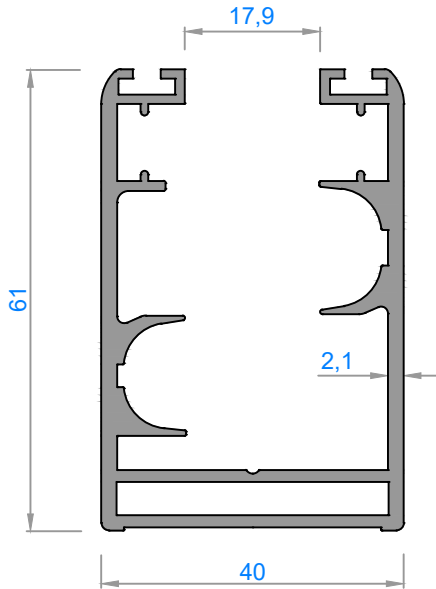

*4119 - 1,349 kg/m

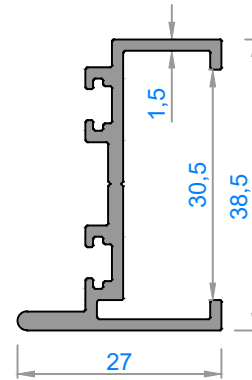

4380 - 0,455 kg/m

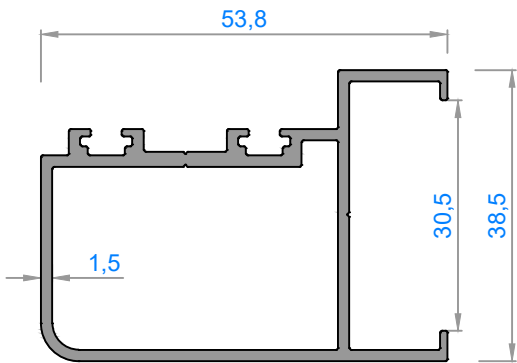

5050 - 0,785 kg/m

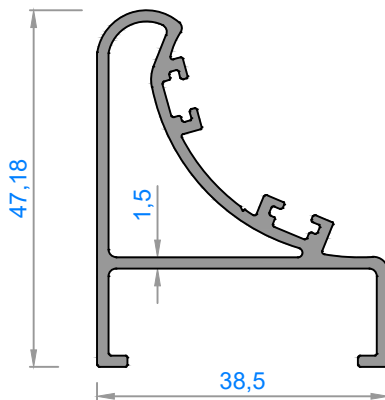

* 4381 - 0,695 kg/m

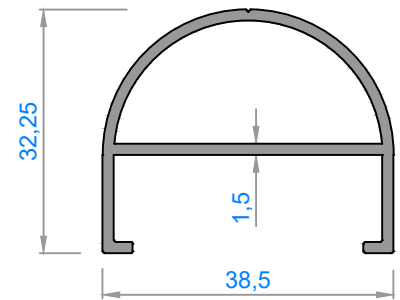

* 4382 - 0,506 kg/m

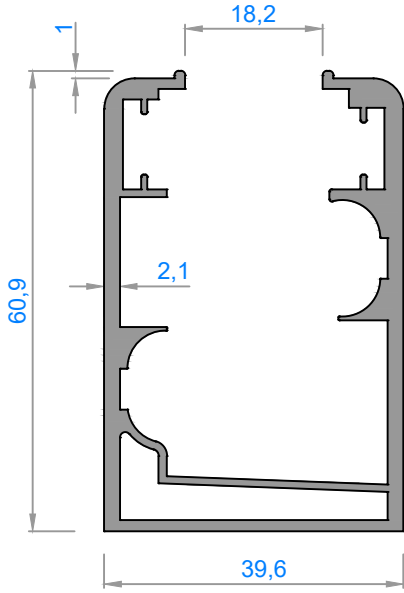

3856 - 1,400 kg/m

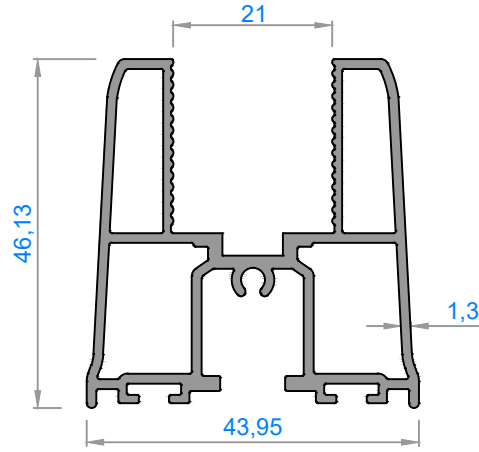

5427 - 1,005 kg/m

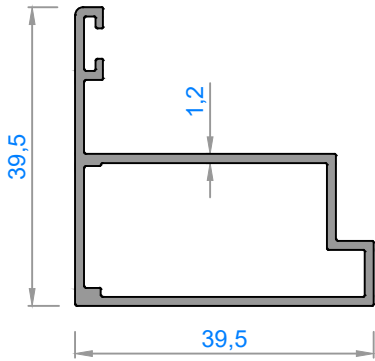

5426 - 0,470 kg/m

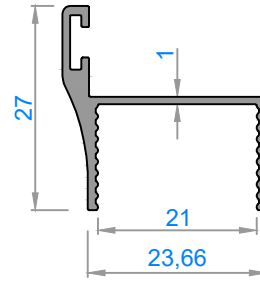

5425 - 0,246 kg/m

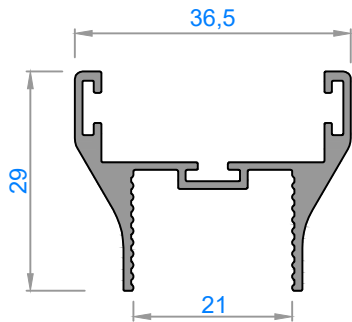

5424 - 0,448 kg/m

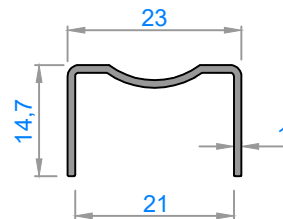

5423 - 0,136 kg/m

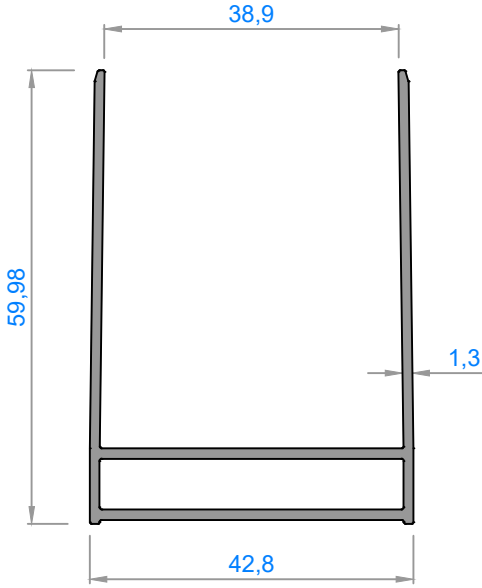

5412 - 0,727 kg/m

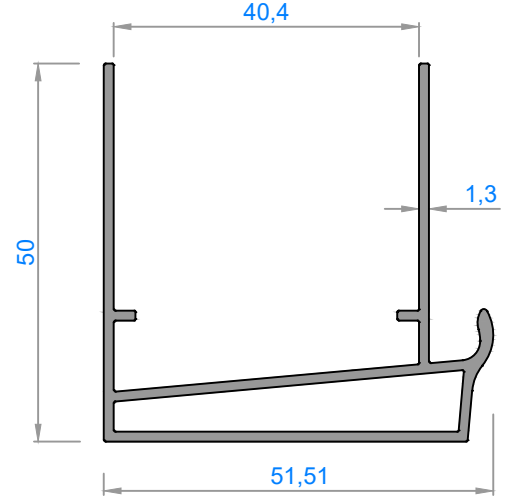

5422 - 0,740 kg/m

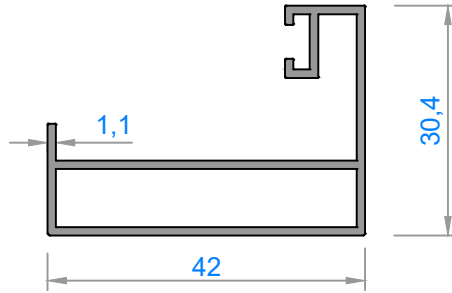

* 4144 - 0,446 kg/m

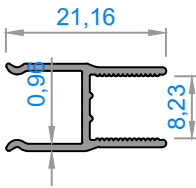

3974 - 0,150 kg/m

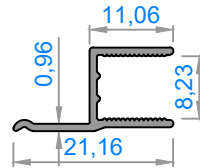

3975 - 0,120 kg/m

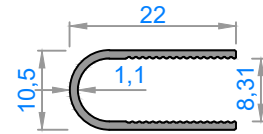

5384 - 0,135 kg/m

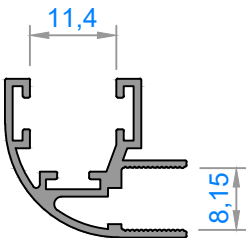

4249 - 0,265 kg/m

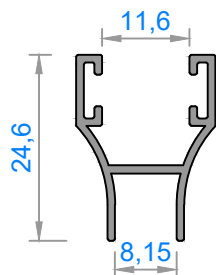

4825 - 0,210 kg/m

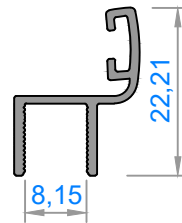

4166 - 0,171 kg/m

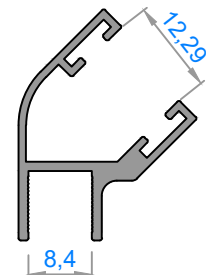

4393 - 0,277 kg/m

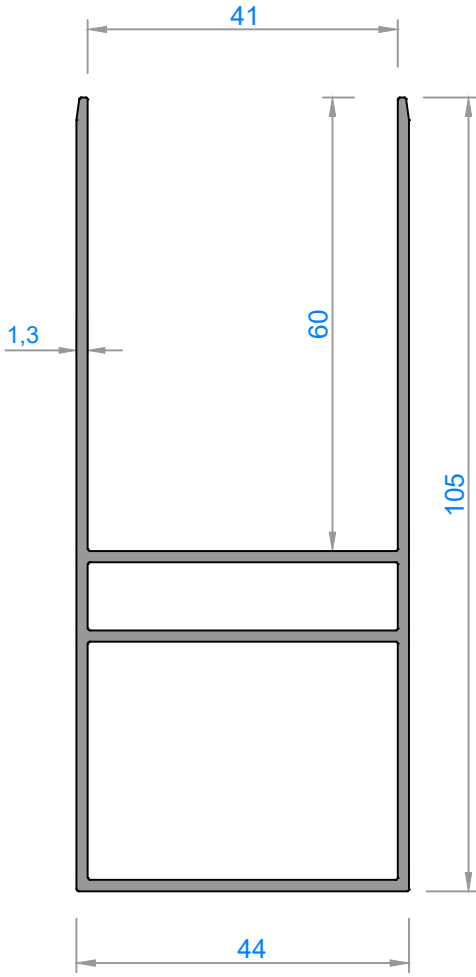

4185 - 1,175 kg/m

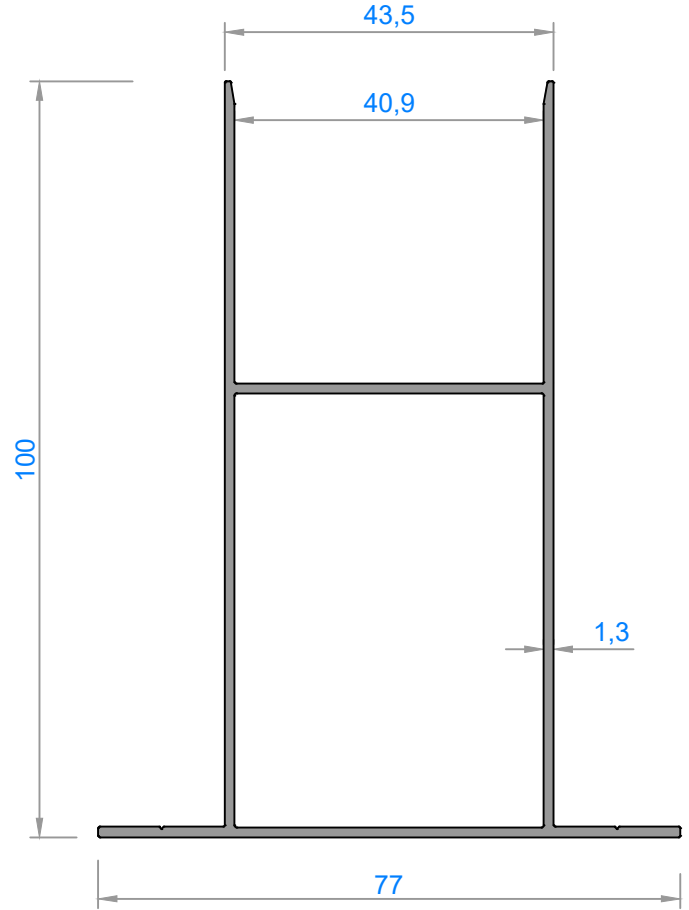

5303 - 1,115 kg/m

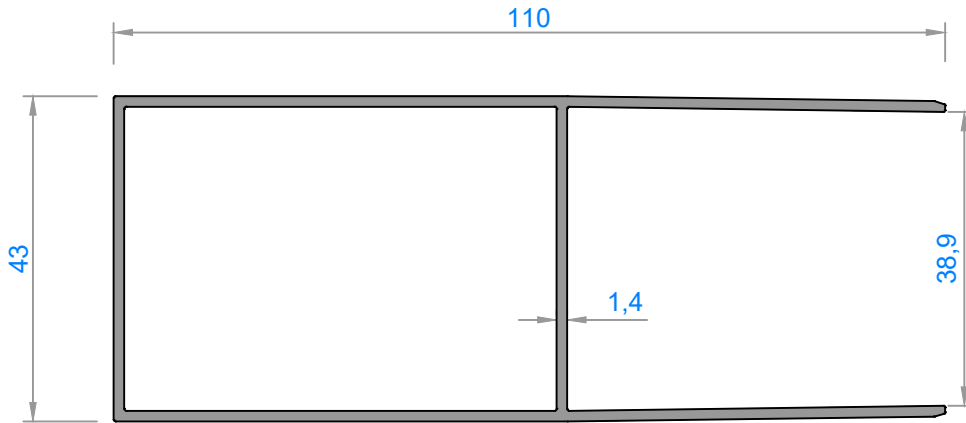

5286 - 1,140 kg/m

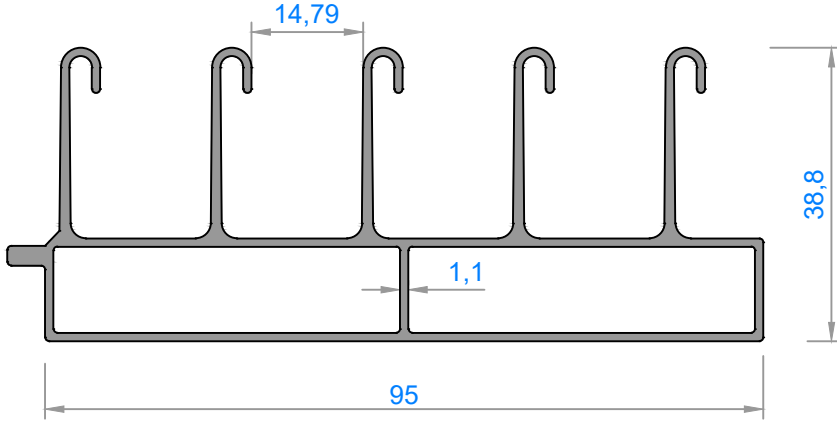

4236 - 1,267 kg/m

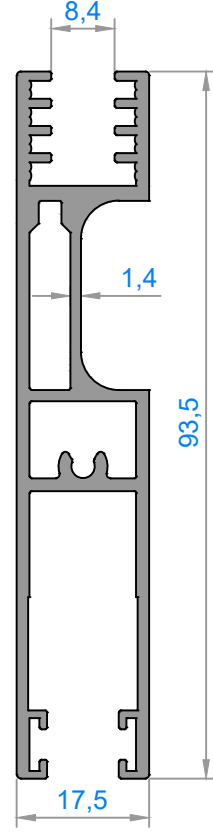

4234 - 1,230 kg/m

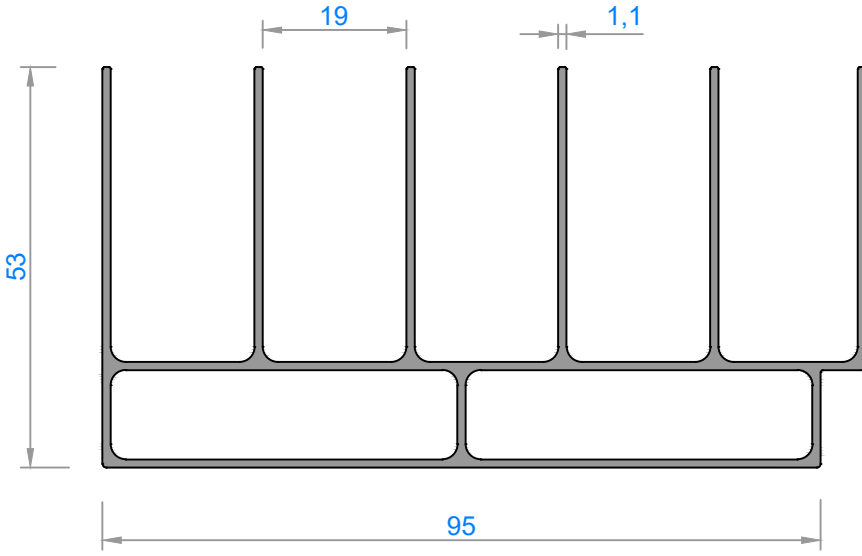

4235 - 1,428 kg/m

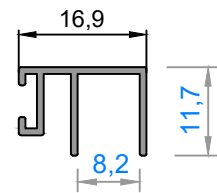

4231 - 0,126 kg/m

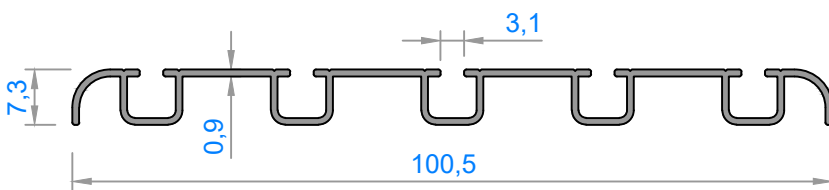

4233 - 0,445 kg/m

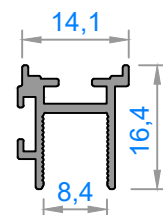

4232 - 0,160 kg/m

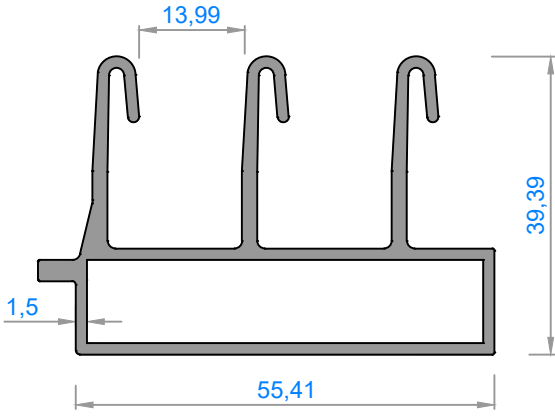

4440 - 1,077 kg/m

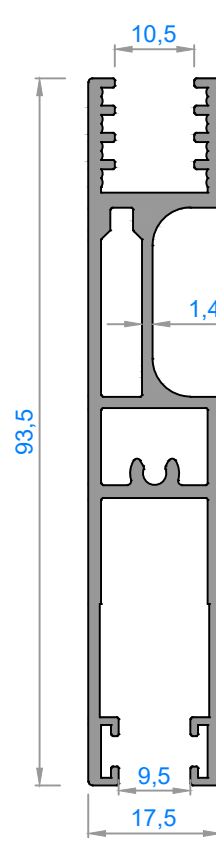

5512 - 1,205 kg/m

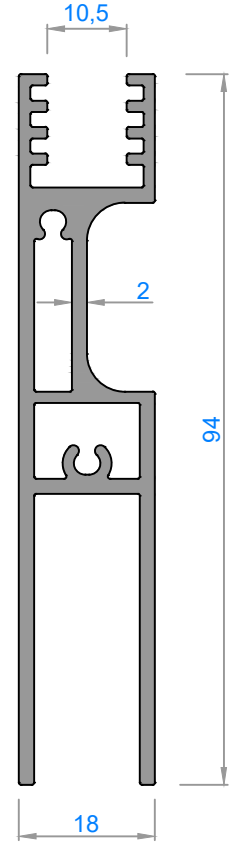

4452 - 1,368 kg/m

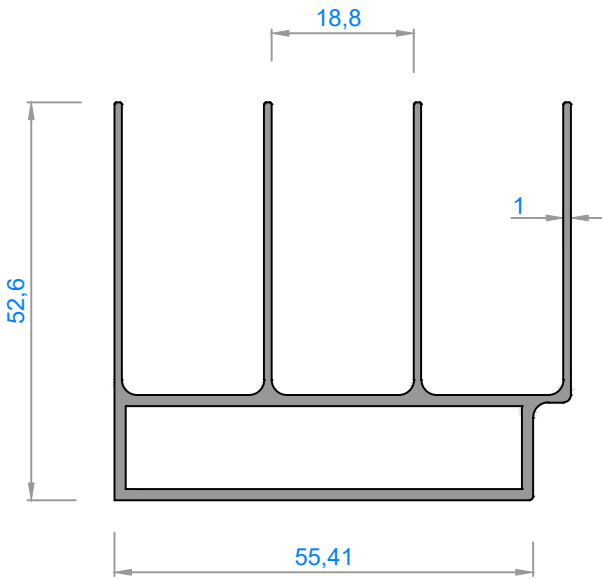

4441 - 0,973 kg/m

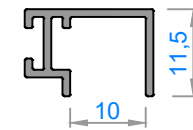

* 4437 - 0,128 kg/m

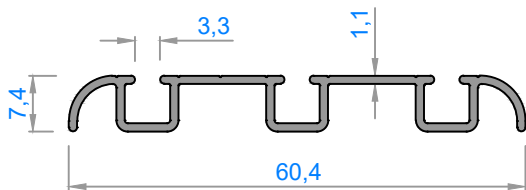

4439 - 0,330 kg/m

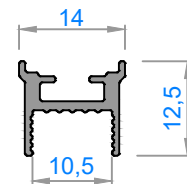

* 4438 - 0,130 kg/m

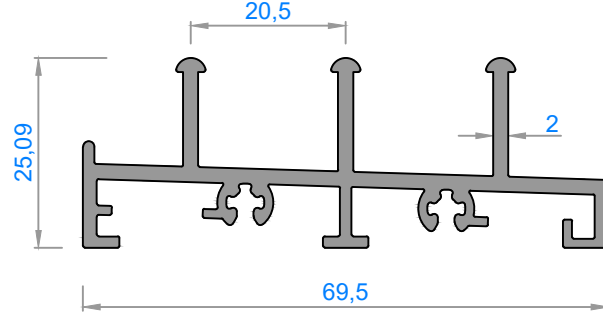

5149 - 0,945 kg/m

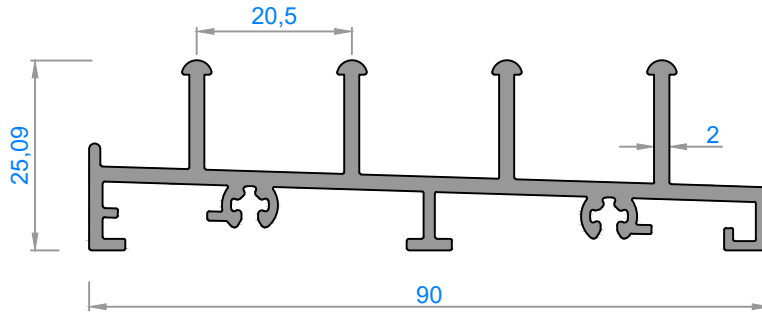

5119 - 1,143 kg/m

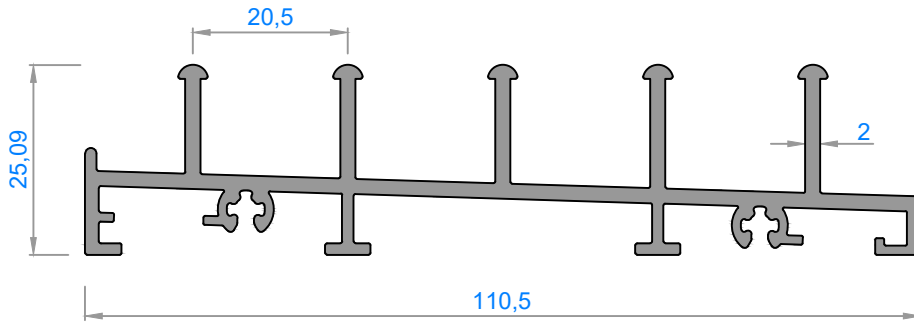

5150 - 1,395 kg/m

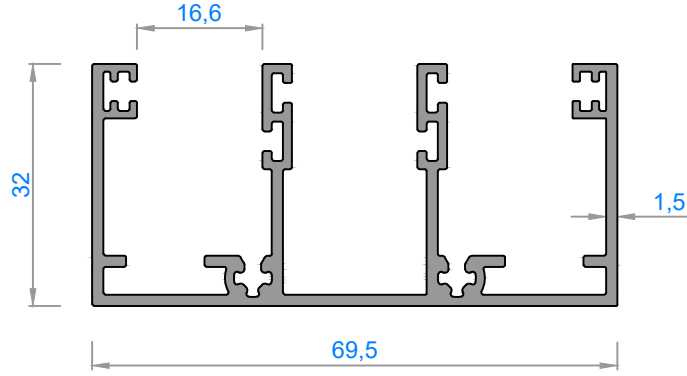

5147 - 1,048 kg/m

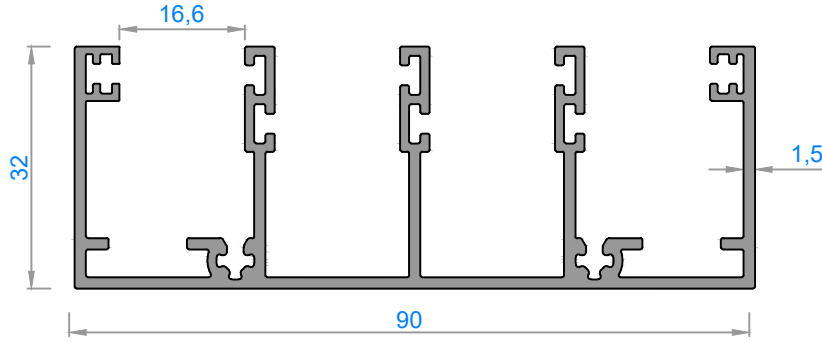

5118 - 1,285 kg/m

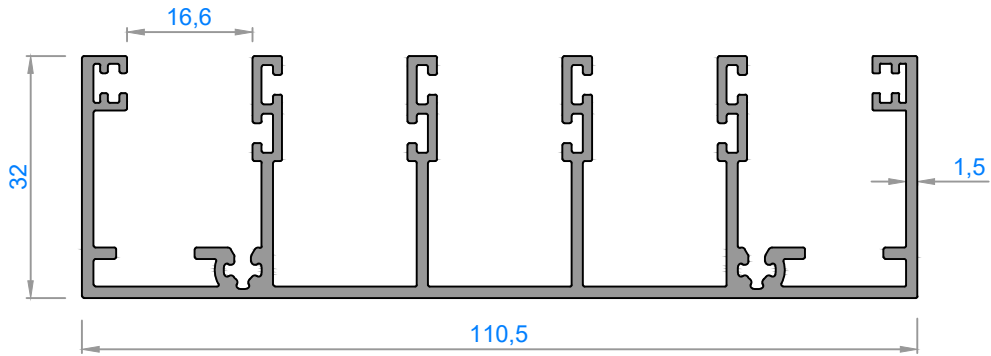

5148 - 1,525 kg/m

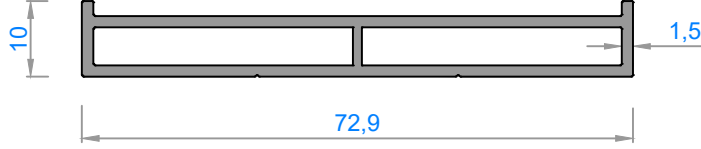

5151 - 0,665 kg/m

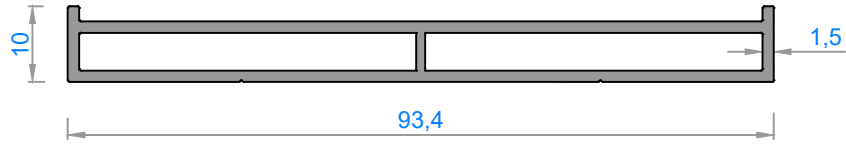

5120 - 0,832 kg/m

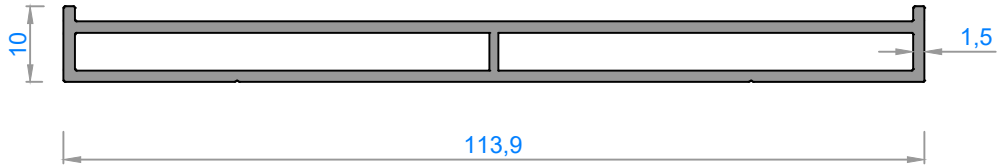

5152 - 1,000 kg/m

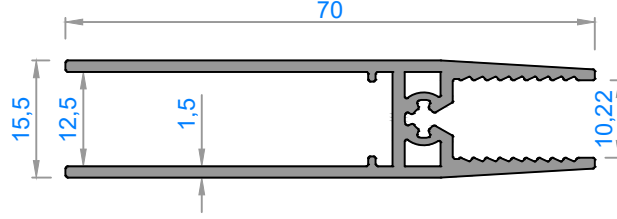

5121 - 0,745 kg/m

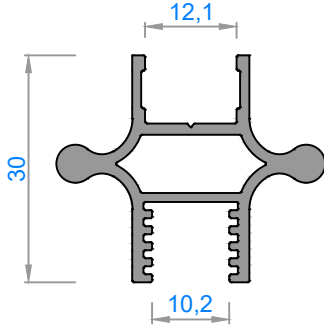

5122 - 0,520 kg/m

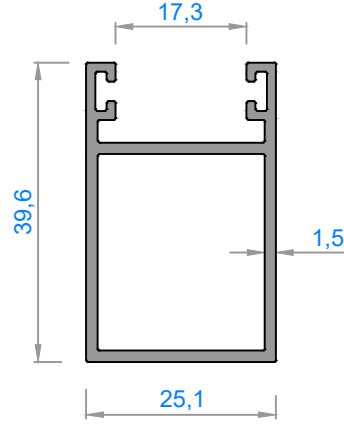

5123 - 0,541 kg/m

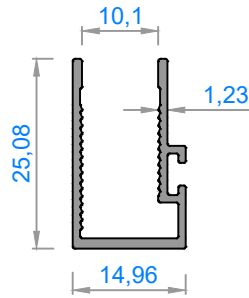

5268 - 0,217 kg/m

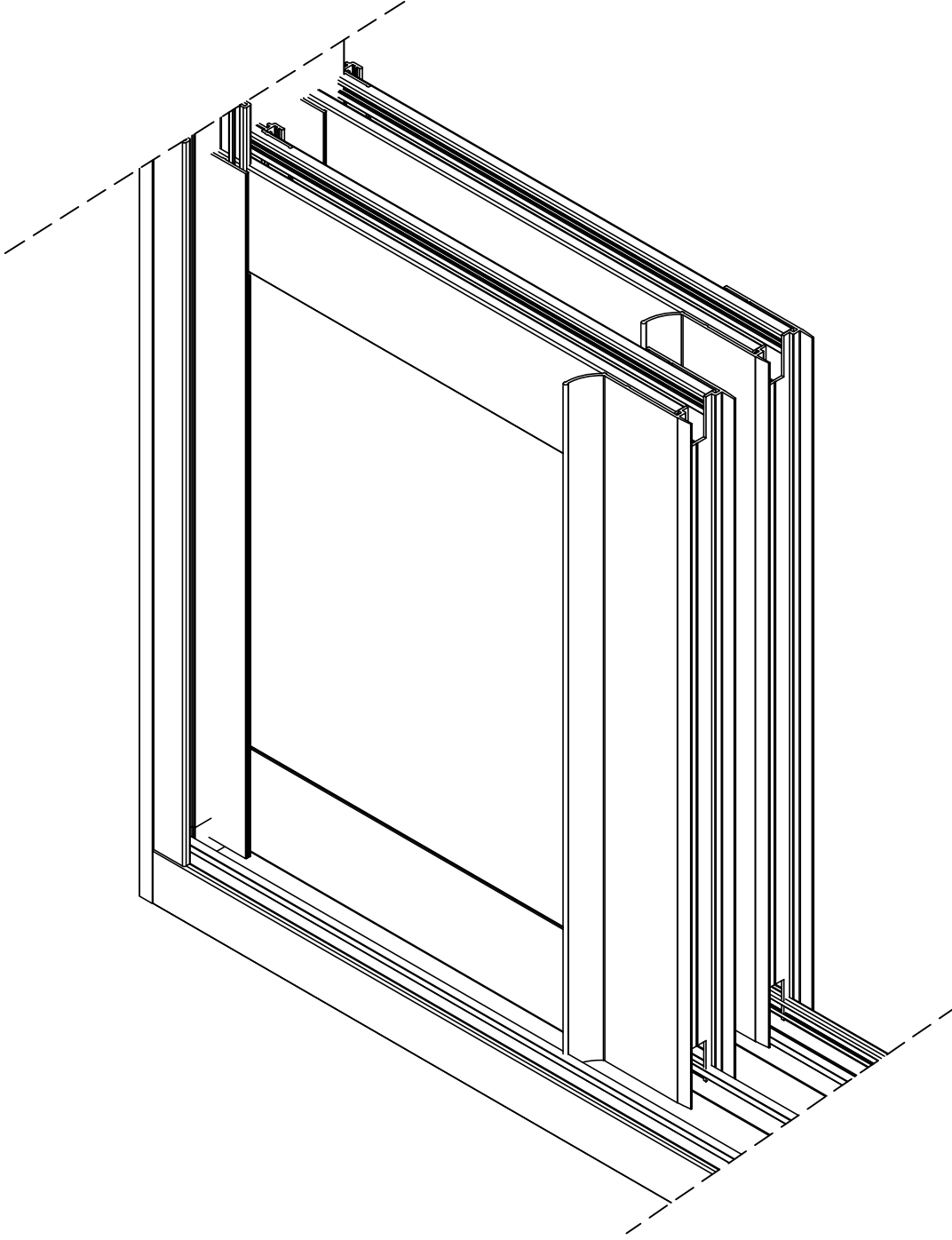

ISI CAMLI SÜRME / Double Glazed Slide



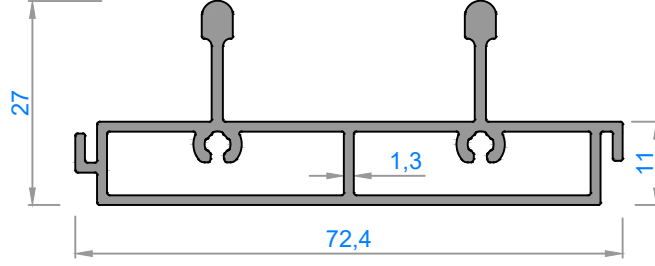

6200 - 0,880 kg/m

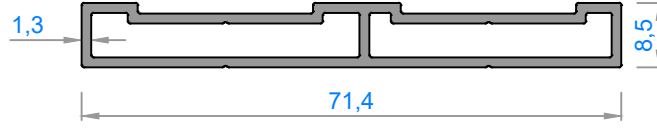

6201 - 0,585 kg/m

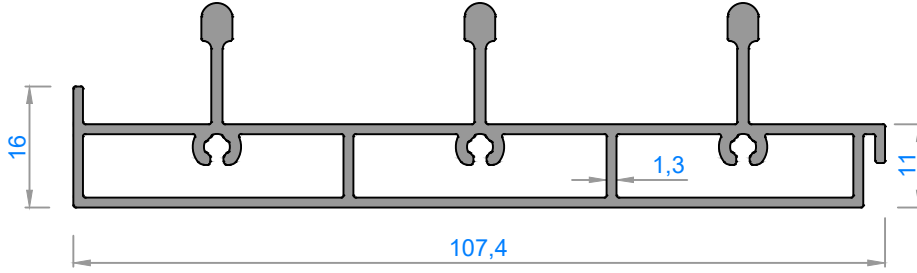

6202 - 1,305 kg/m

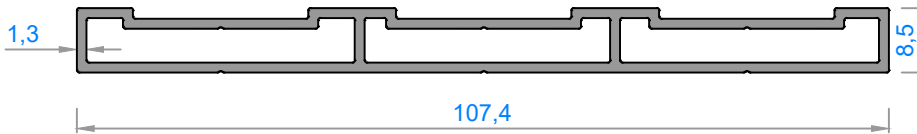

6203 - 0,870 kg/m

EK KASA MODELLERİ

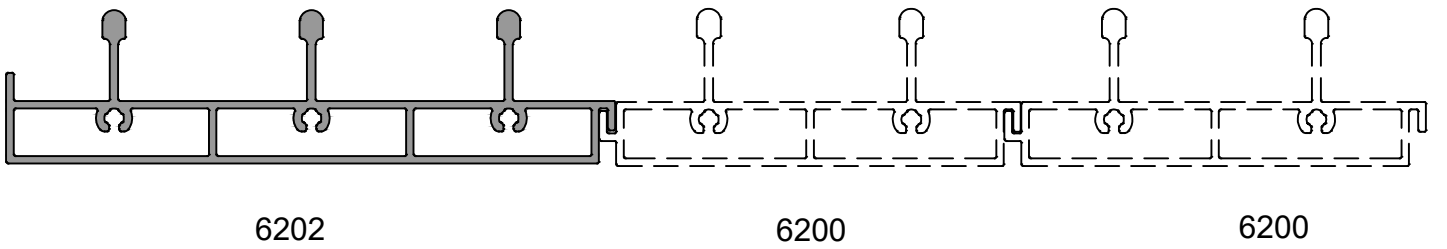
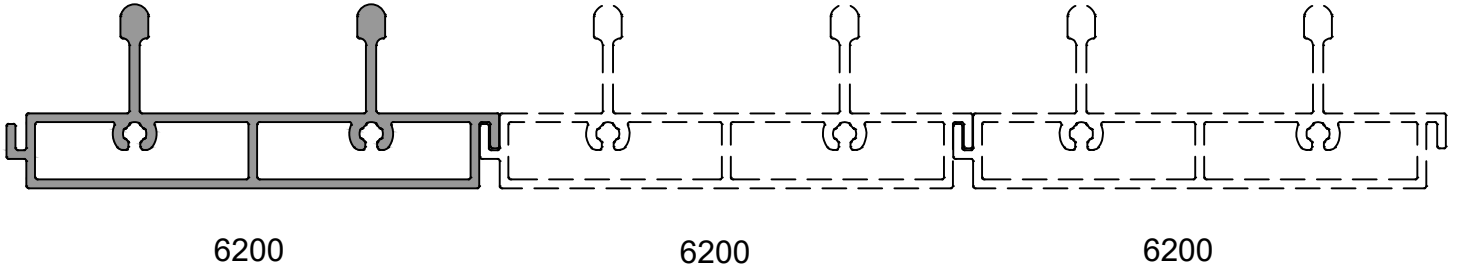
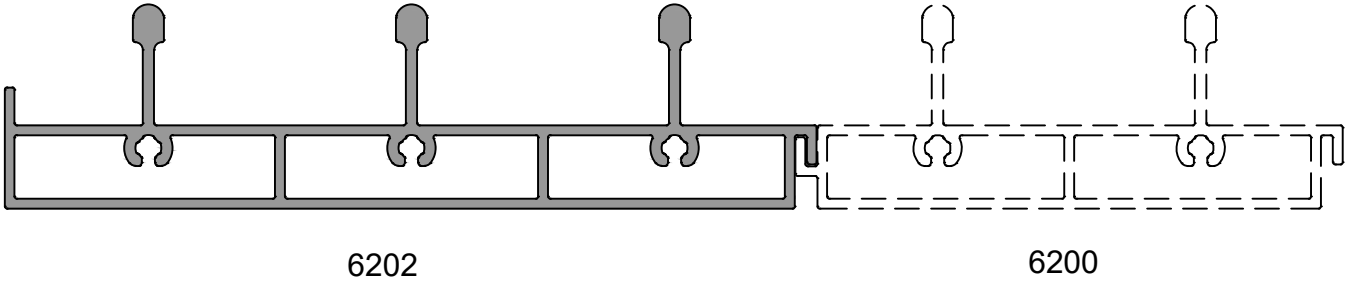
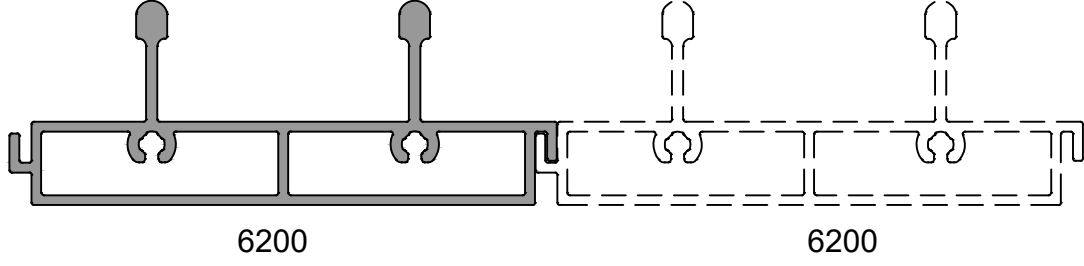

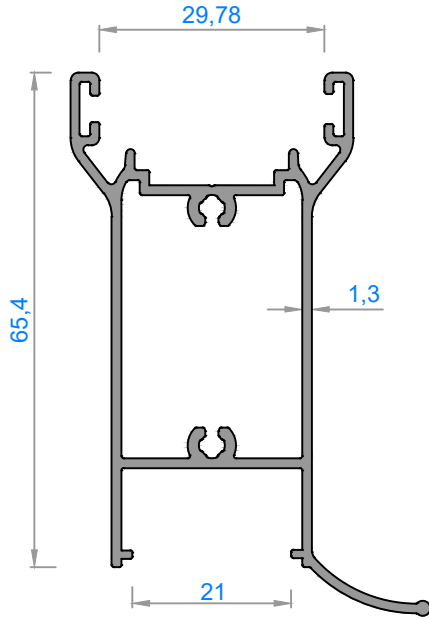

6204 - 0,890 kg/m

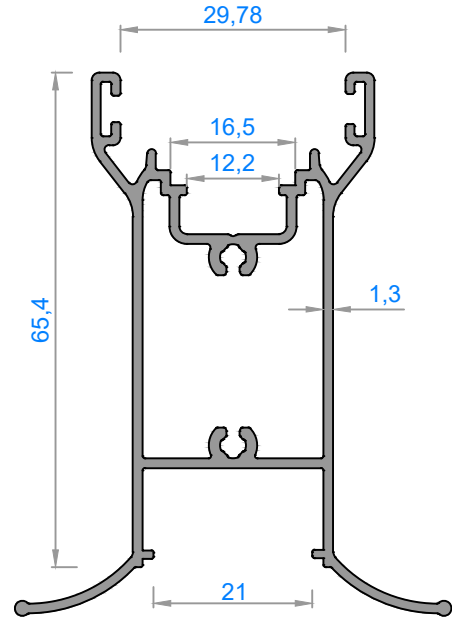

6209 - 1,005 kg/m

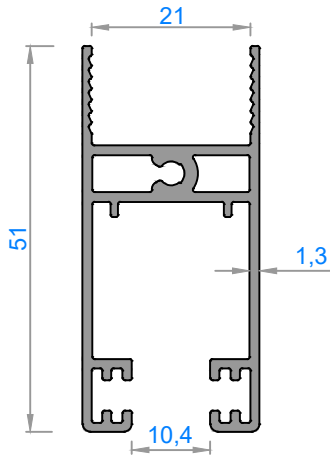

6205 - 0,650 kg/m

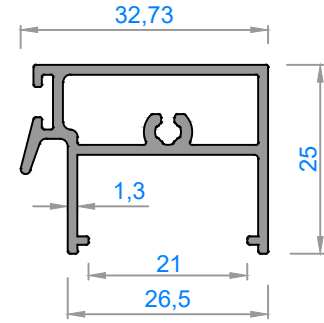

6206 - 0,455 kg/m

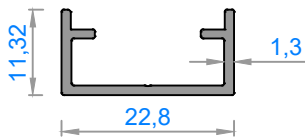

6207 - 0,170 kg/m

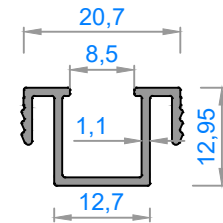

6208 - 0,180 kg/m

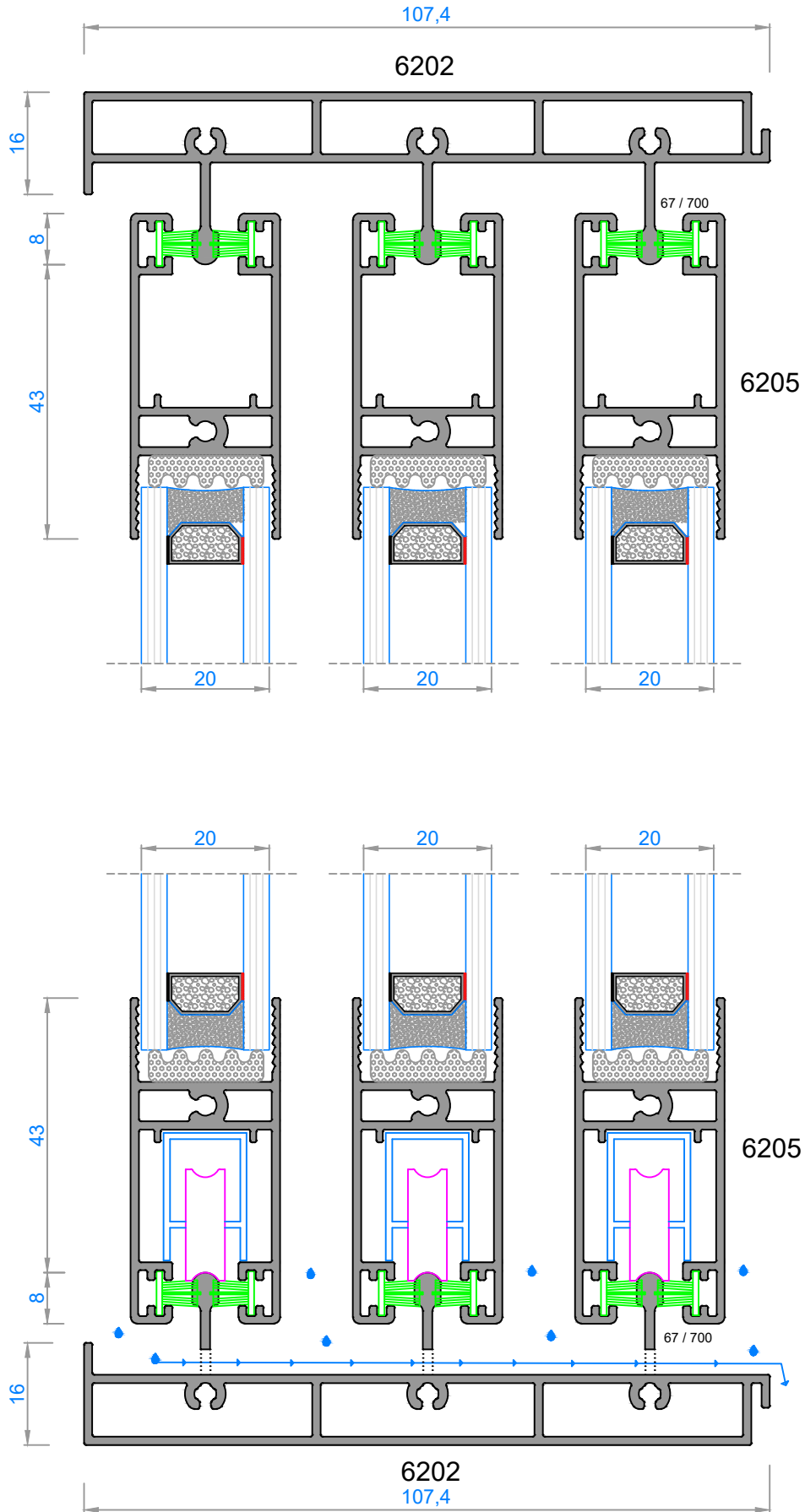

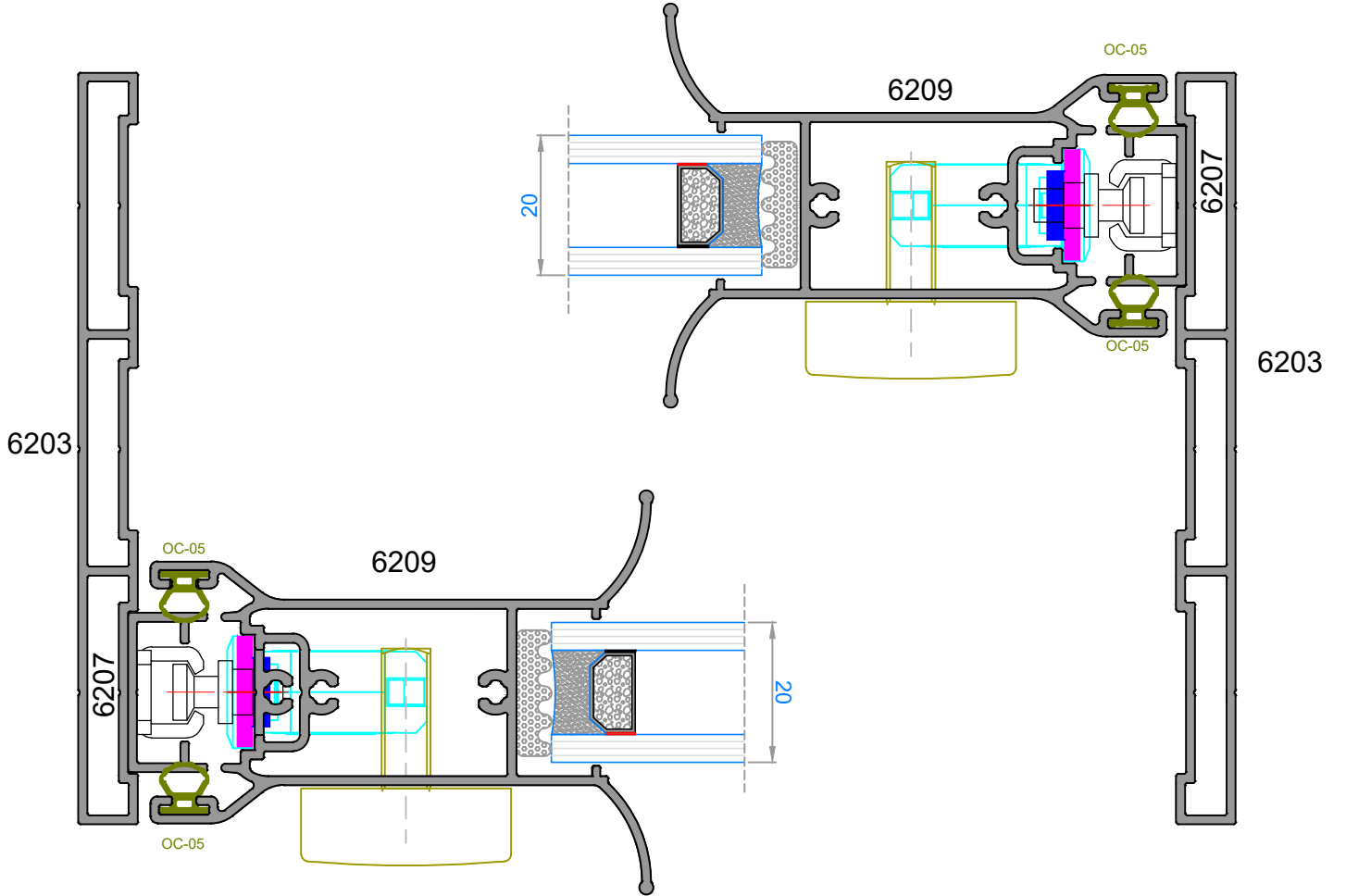
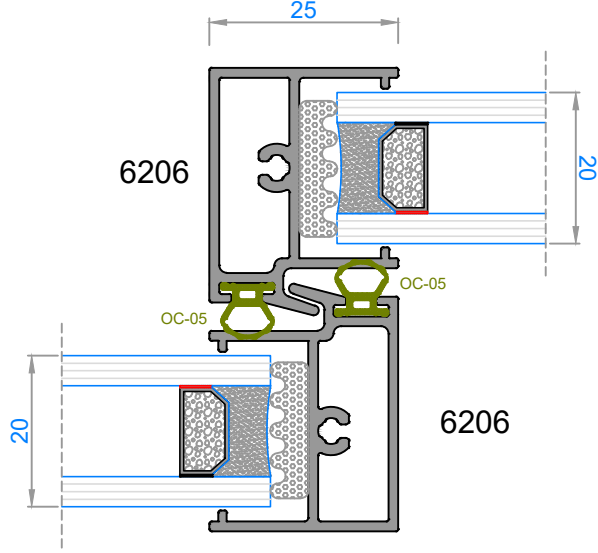

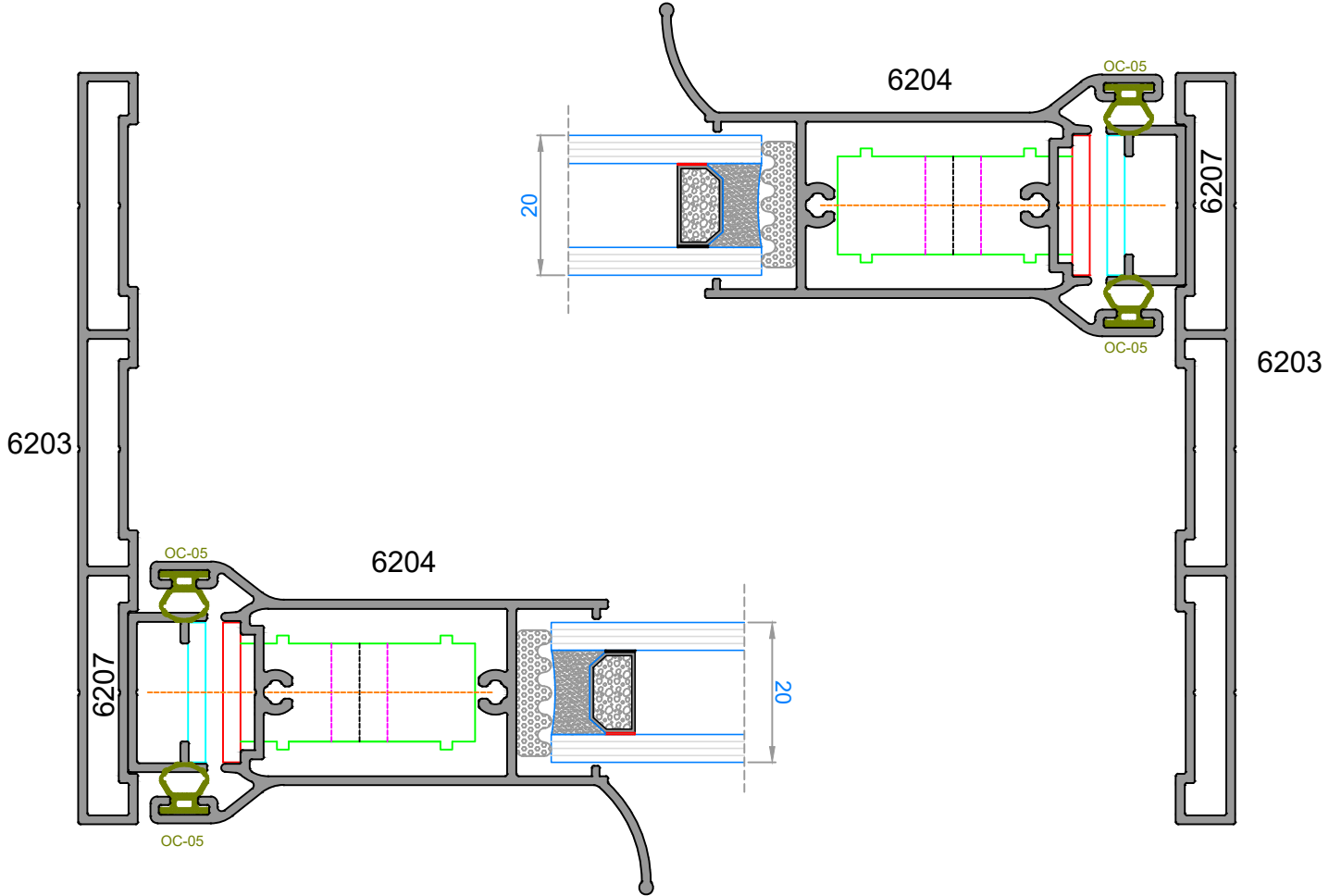
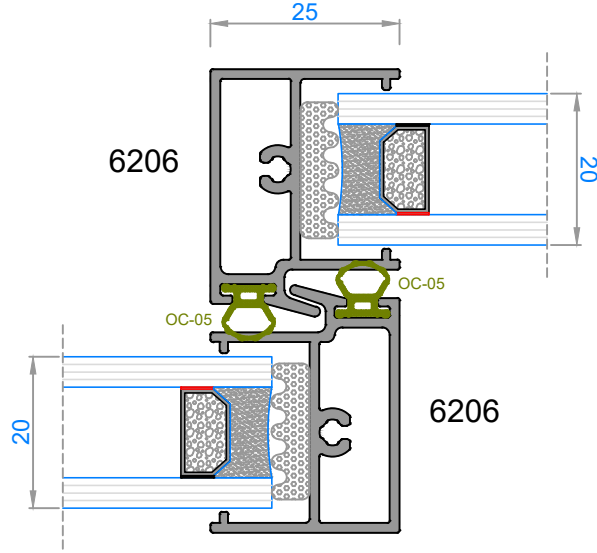

KASA MONTAJ DETAYI

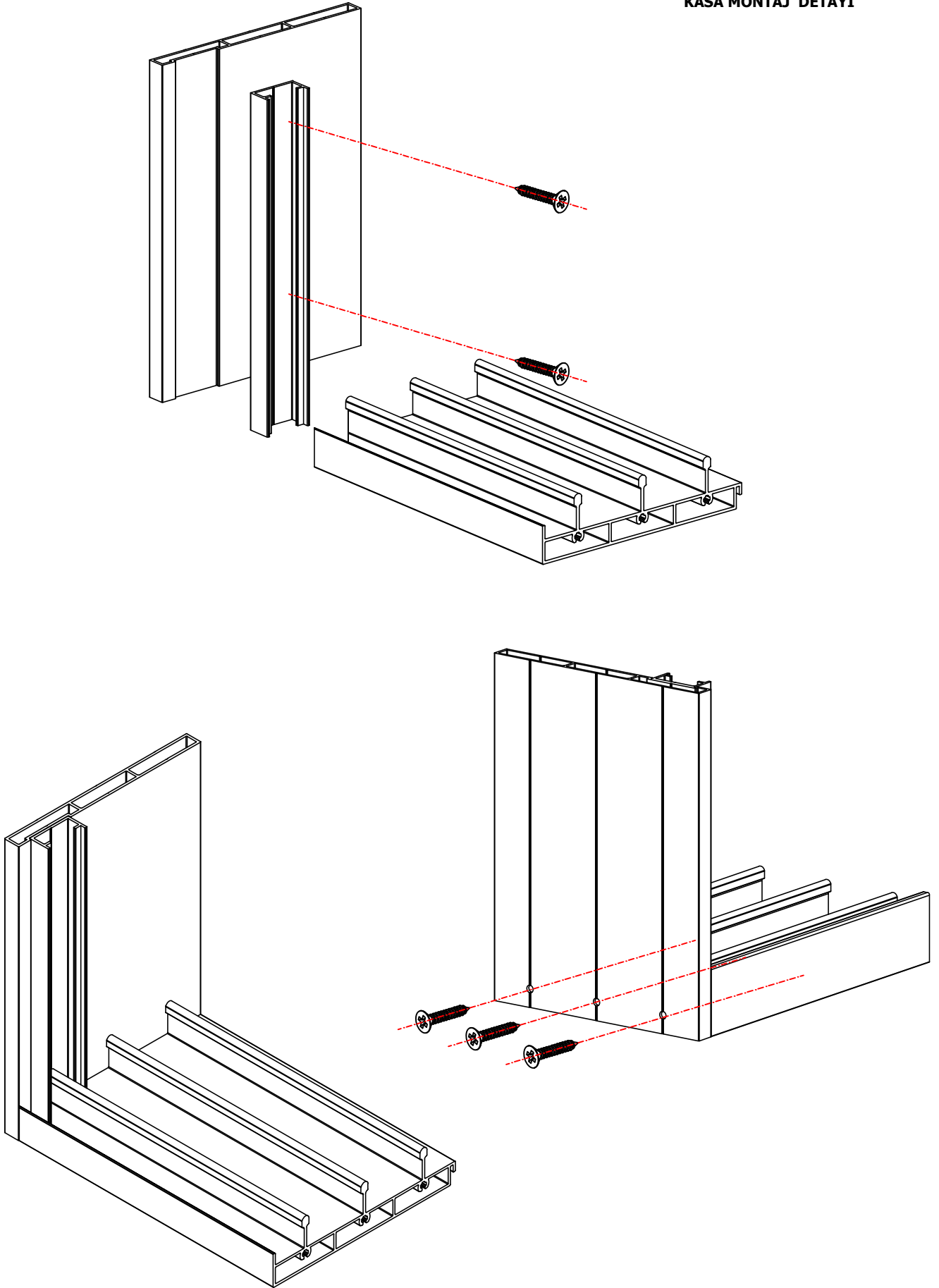

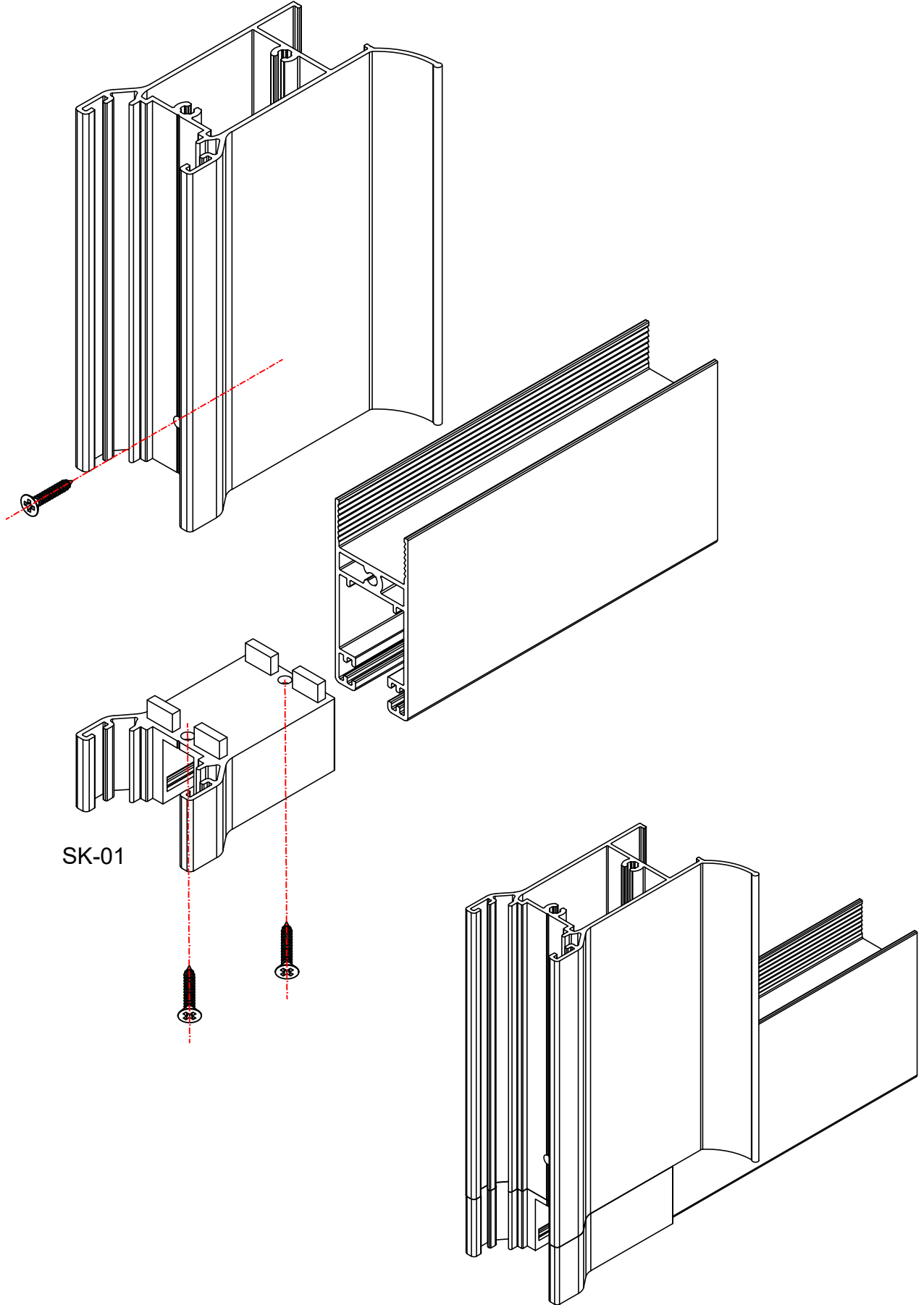

KENET MONTAJ DETAYI

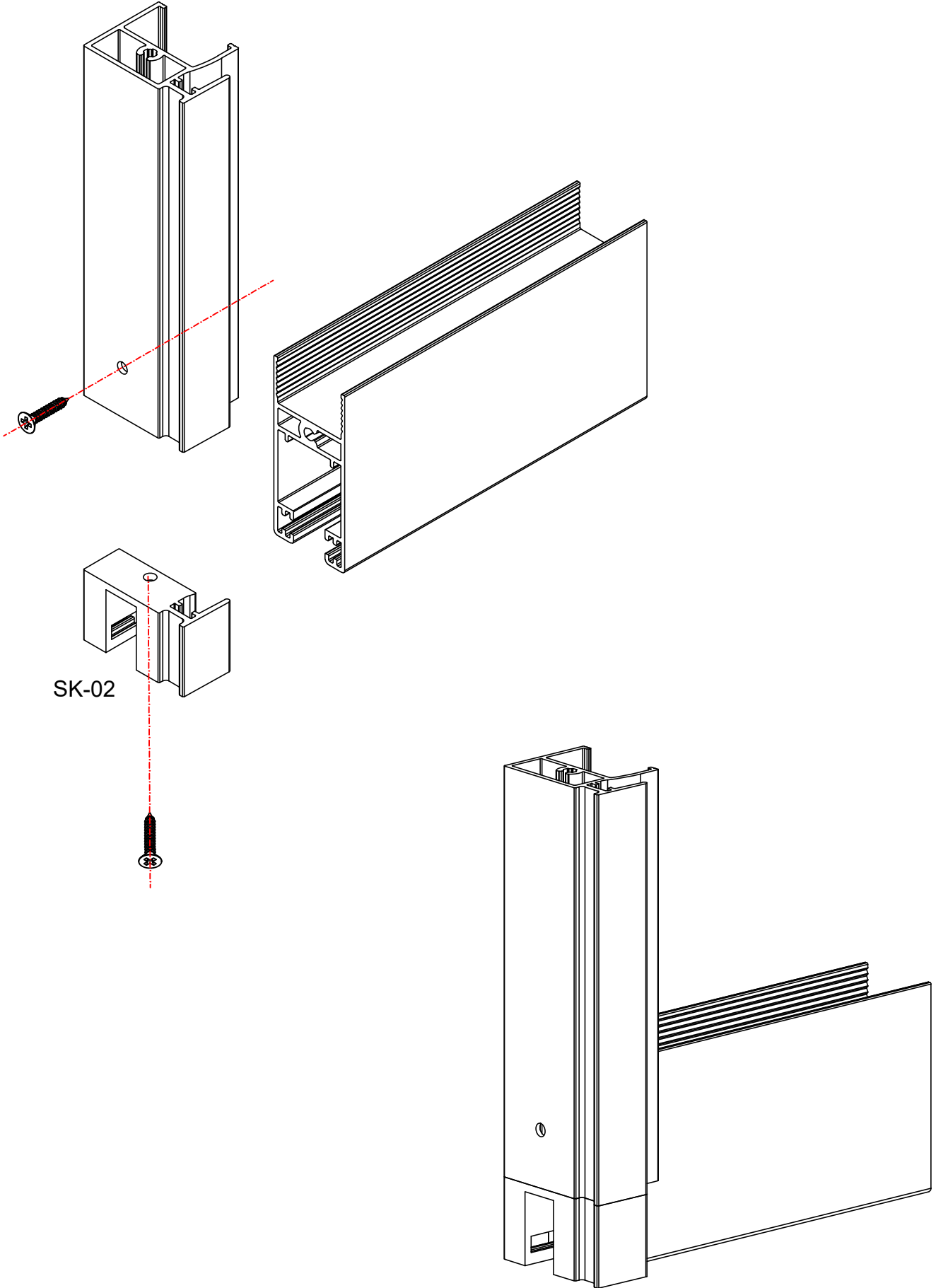

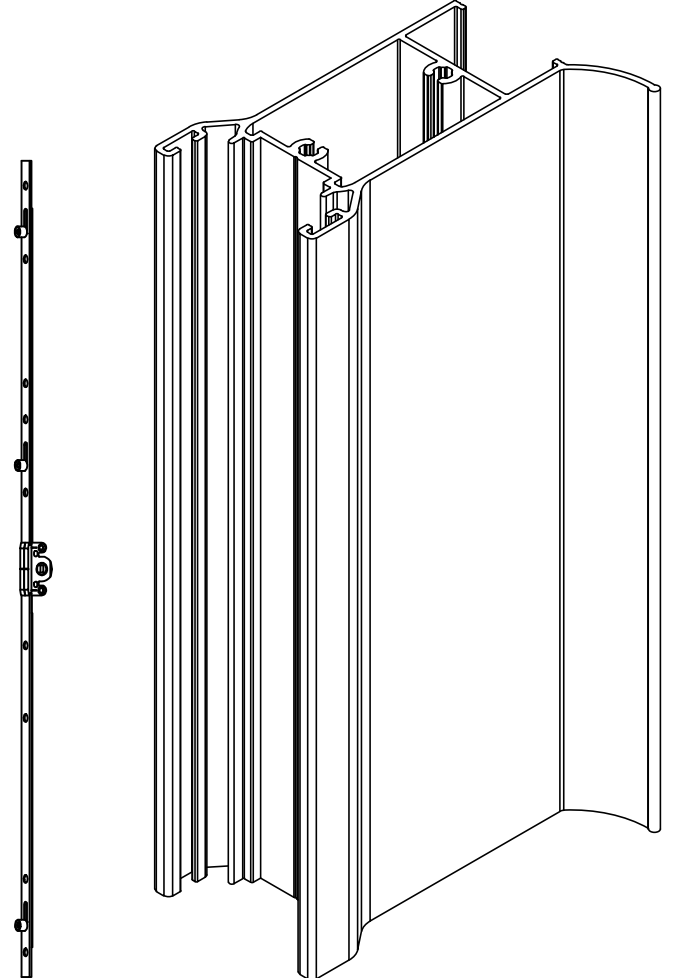
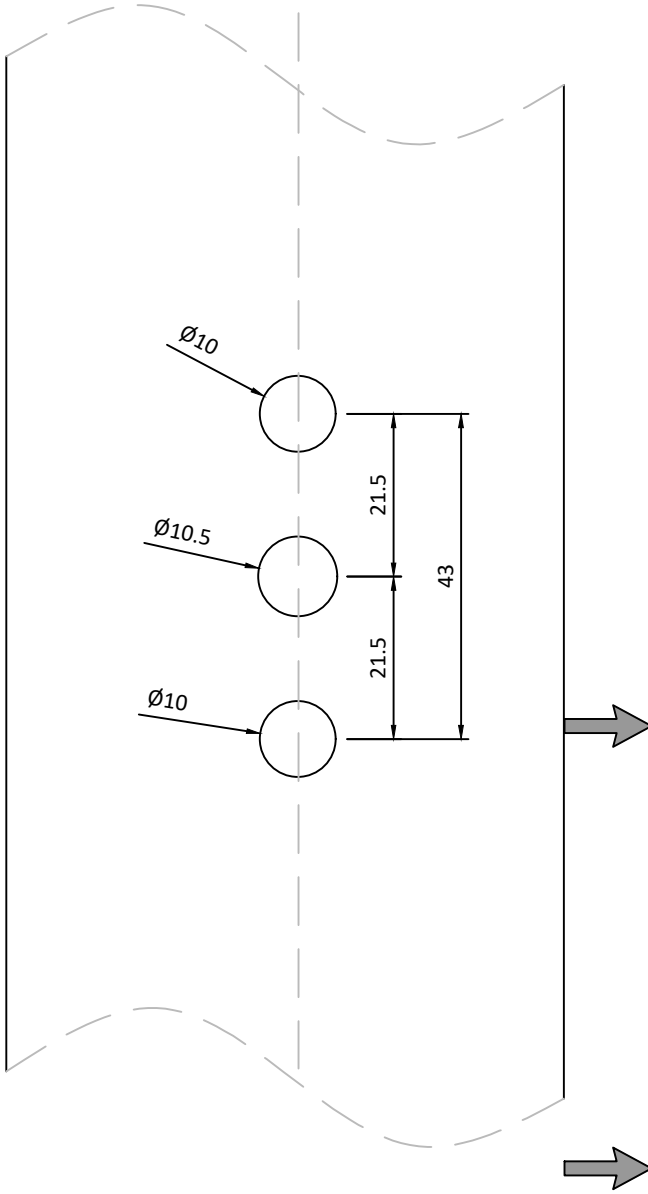
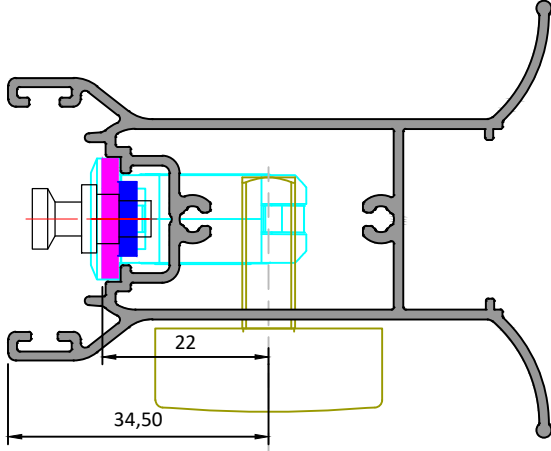

KANCALI KİLİT MONTAJ DETAYI

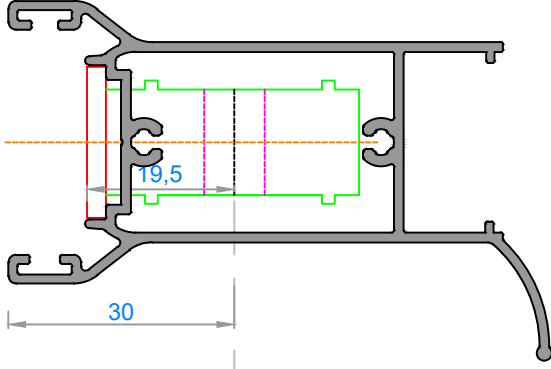

..1.1./downloads/klir 2.jpeg

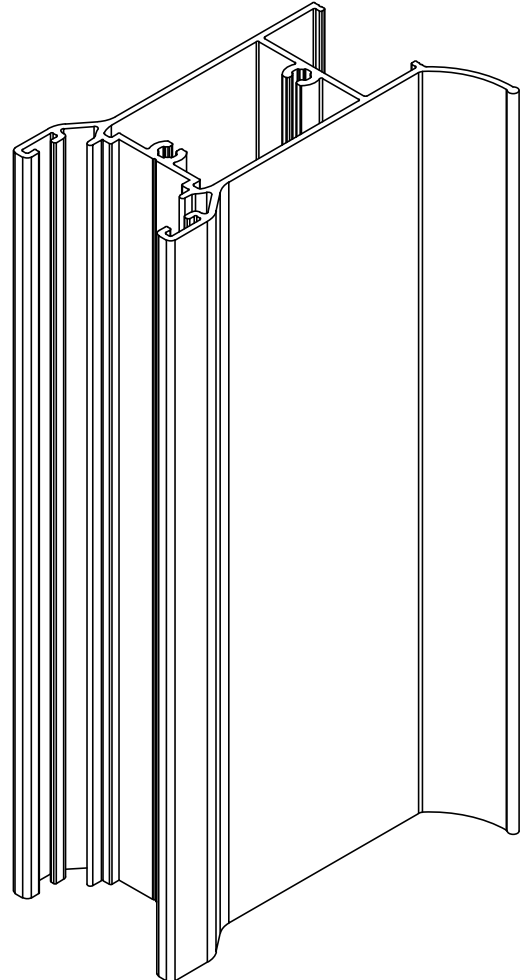
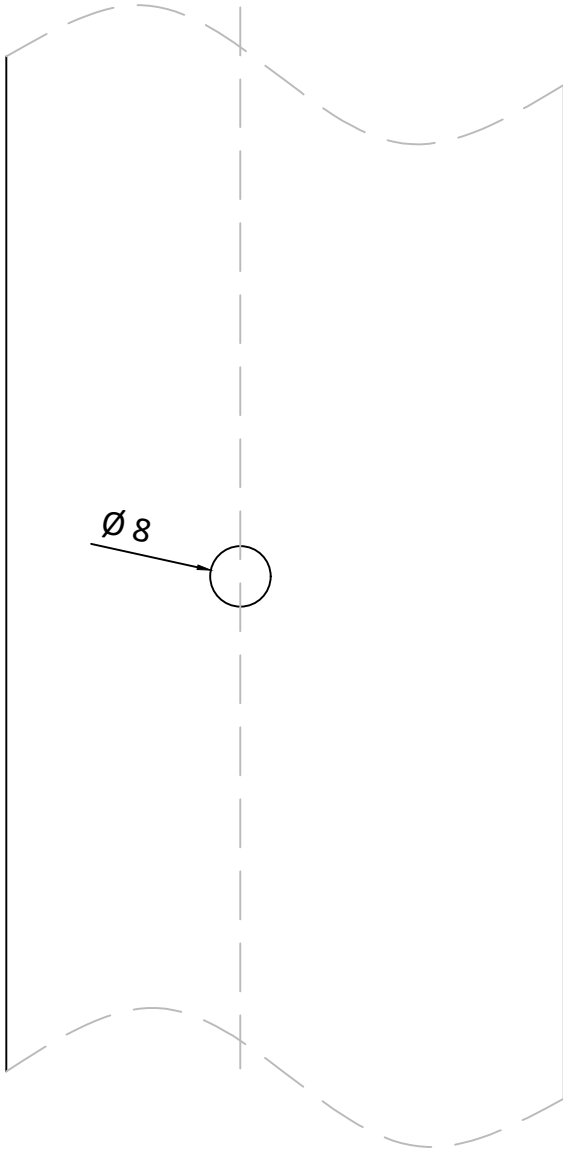

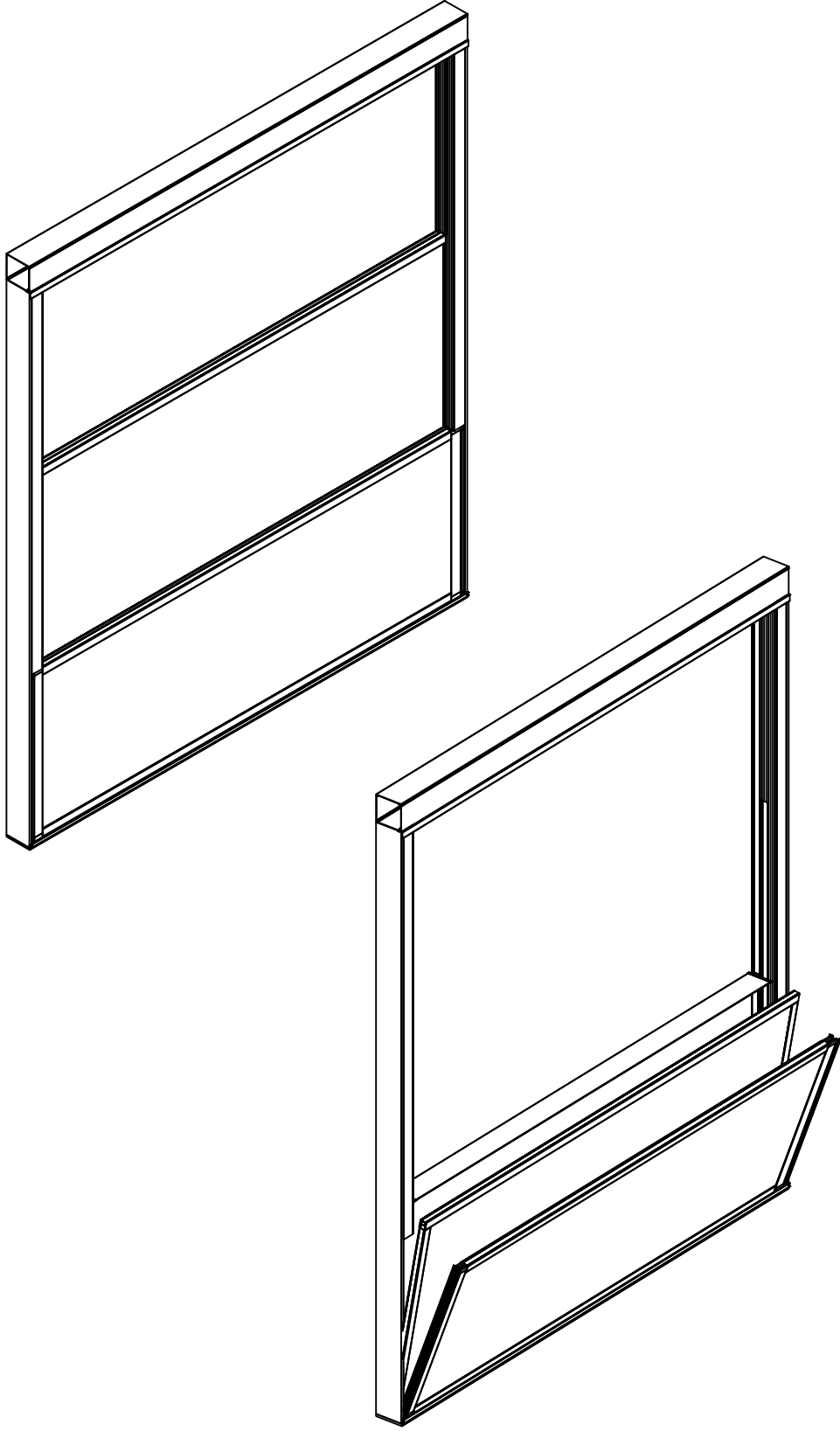

GİYOTİN SİSTEMLERİ / Guillotine Systems

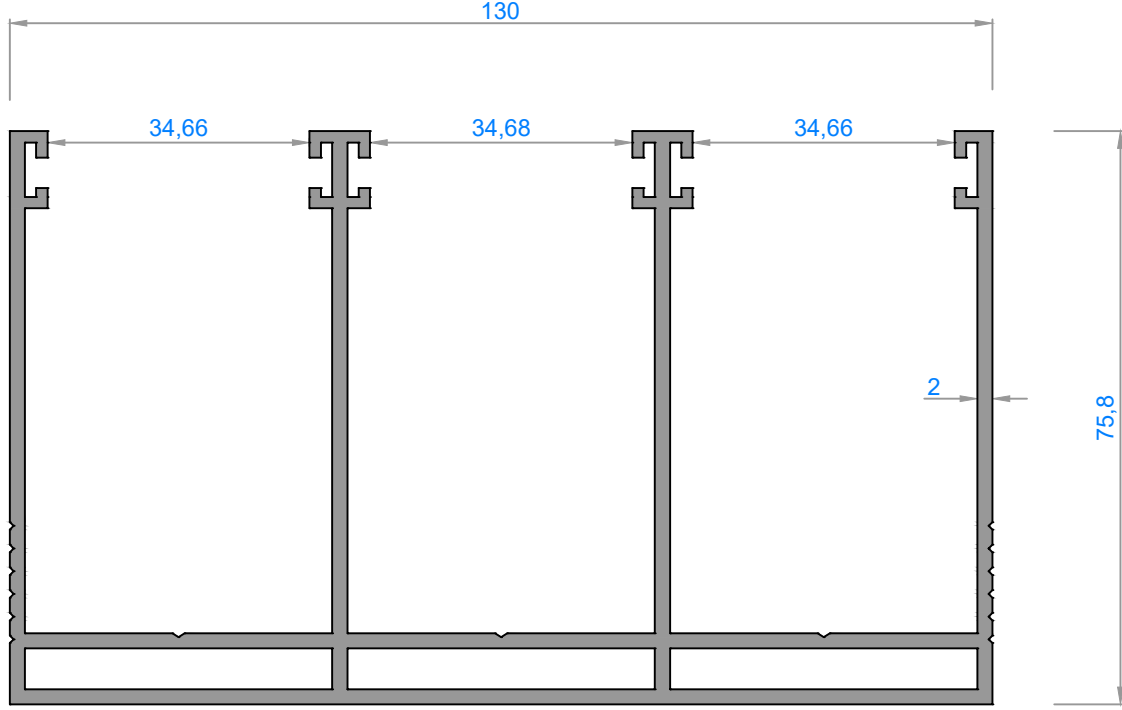

5394 - 3,179 kg/m

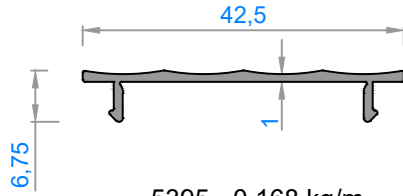

5395 - 0,168 kg/m

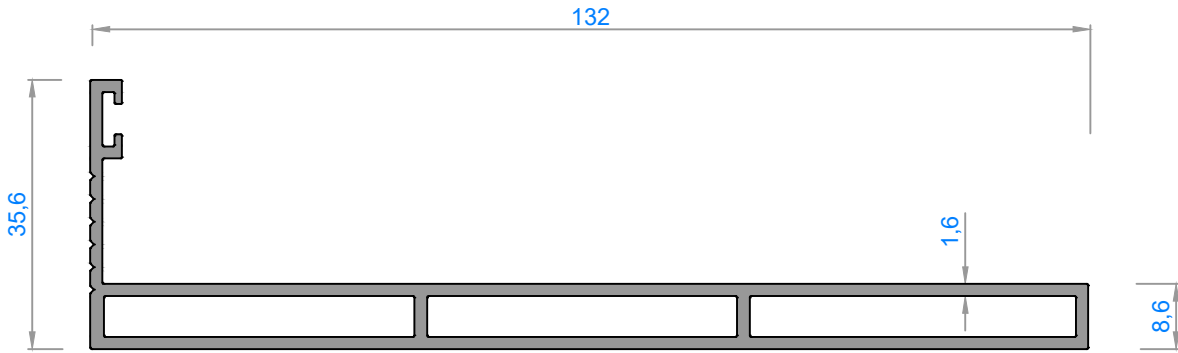

5396 - 1,388 kg/m

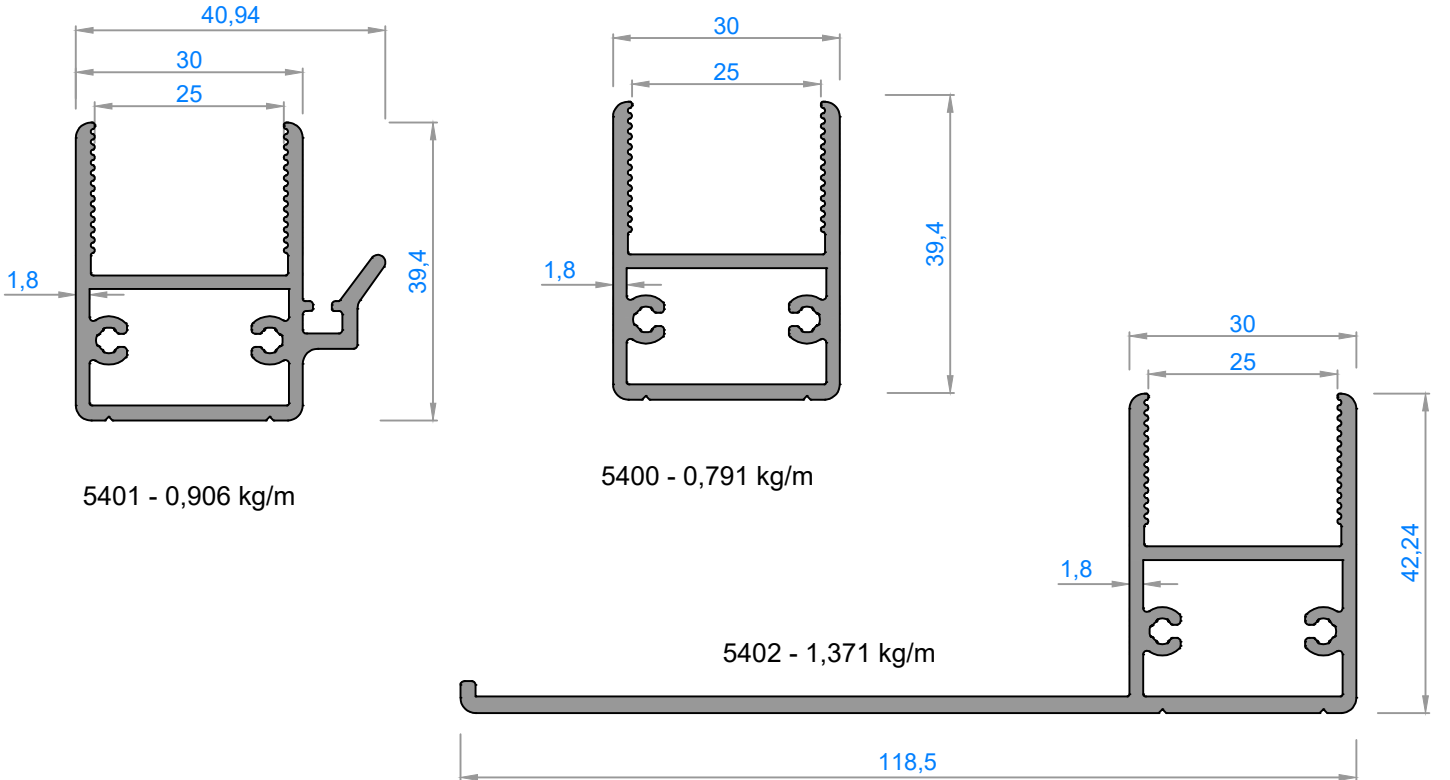
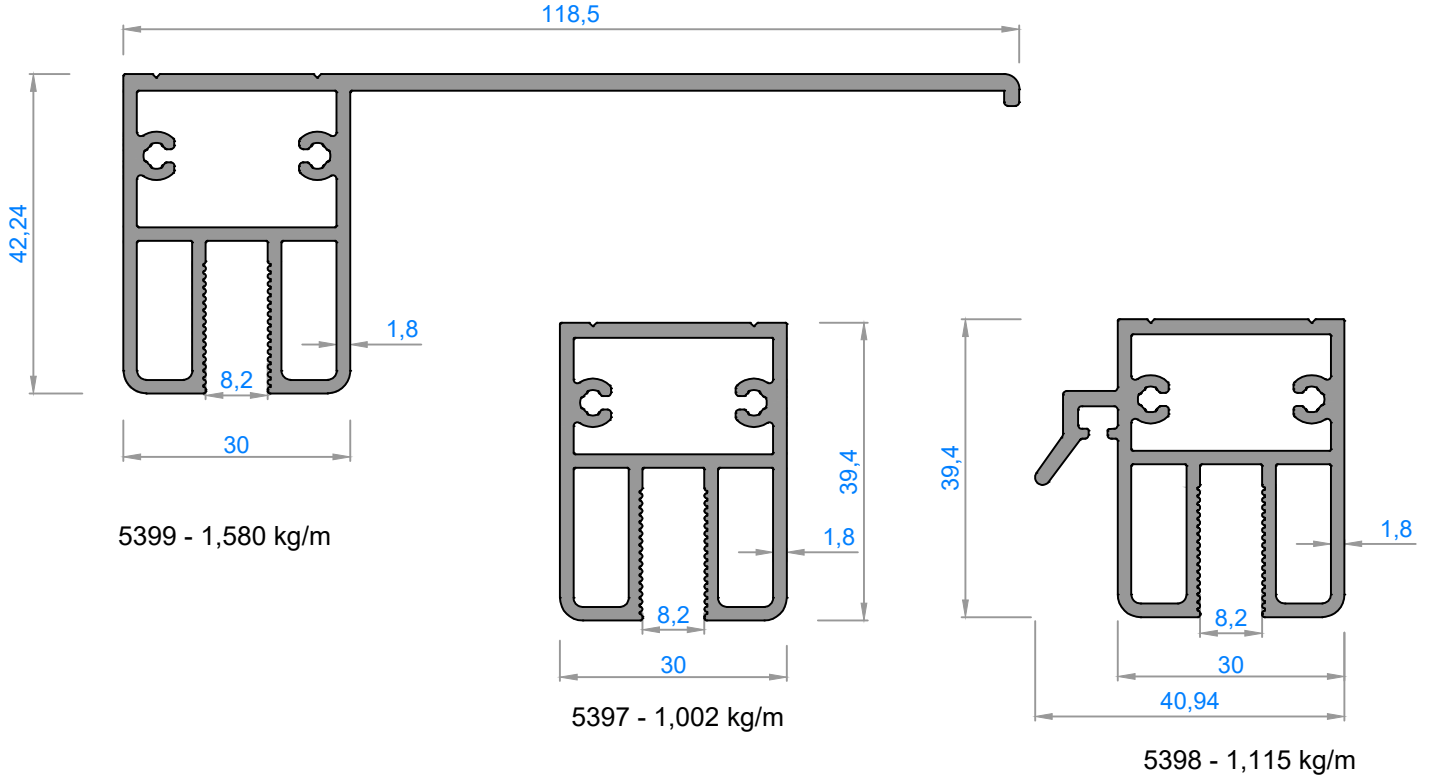

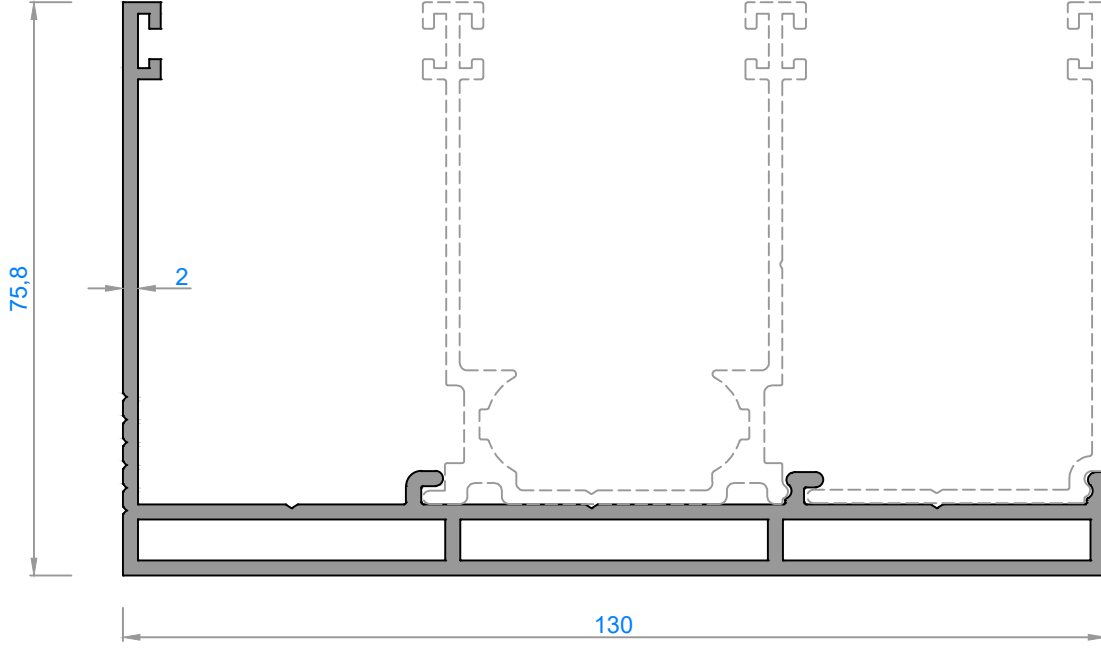

5986 - 2,013 kg/m

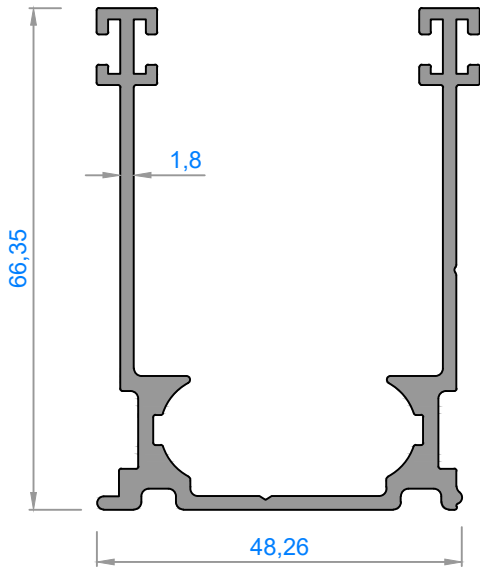

5985 - 1,237 kg/m

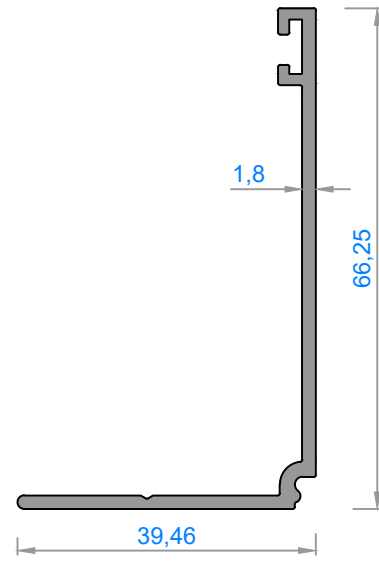

5981 - 0,546 kg/m

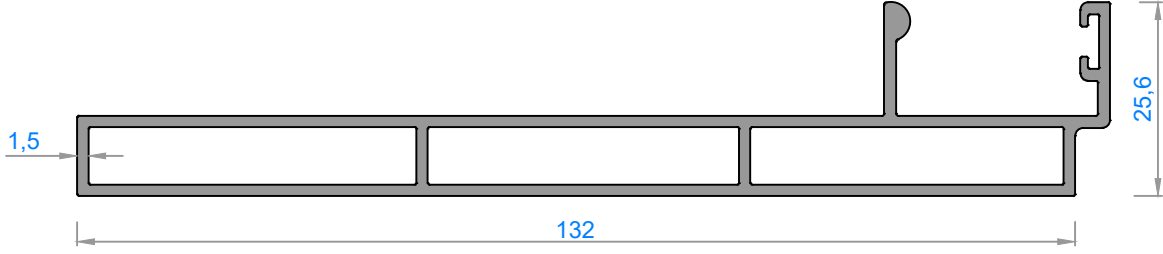

5987 - 1,390 kg/m

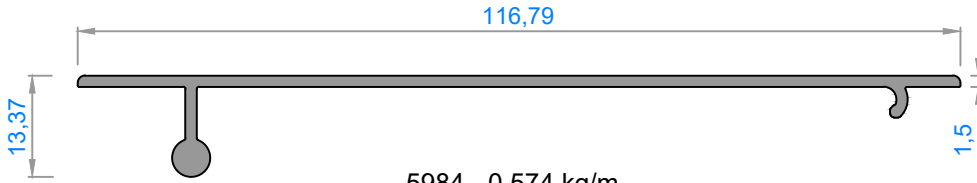

5984 - 0,574 kg/m

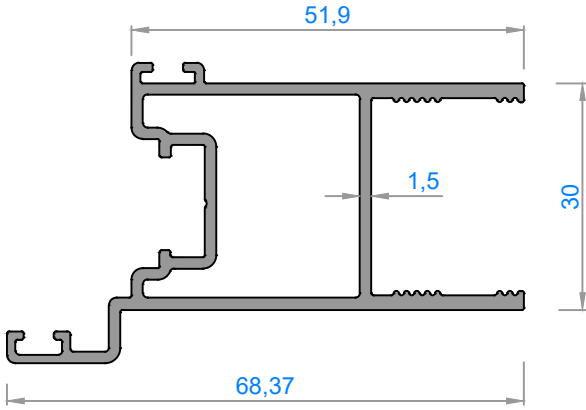

5983 - 0,936 kg/m

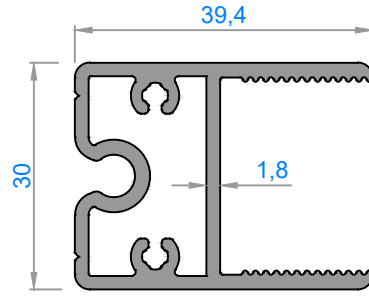

5982 - 0,850 kg/m

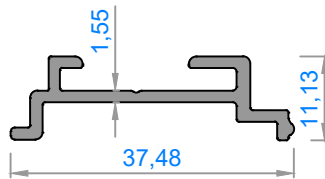

5980 - 0,277 kg/m

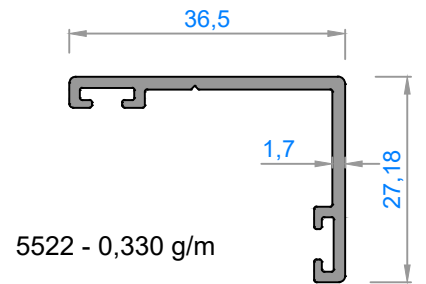
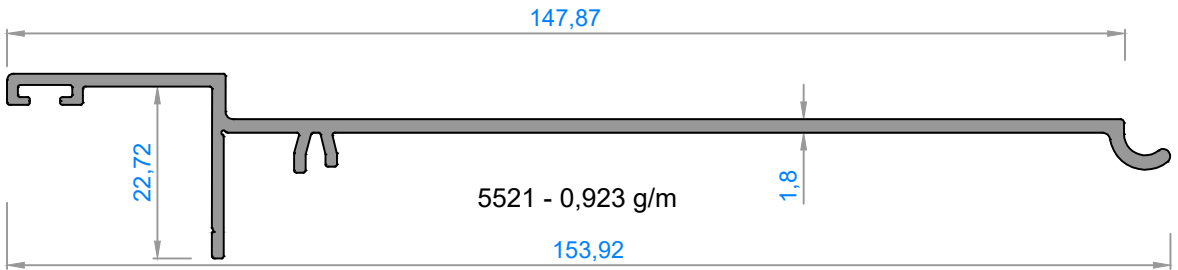
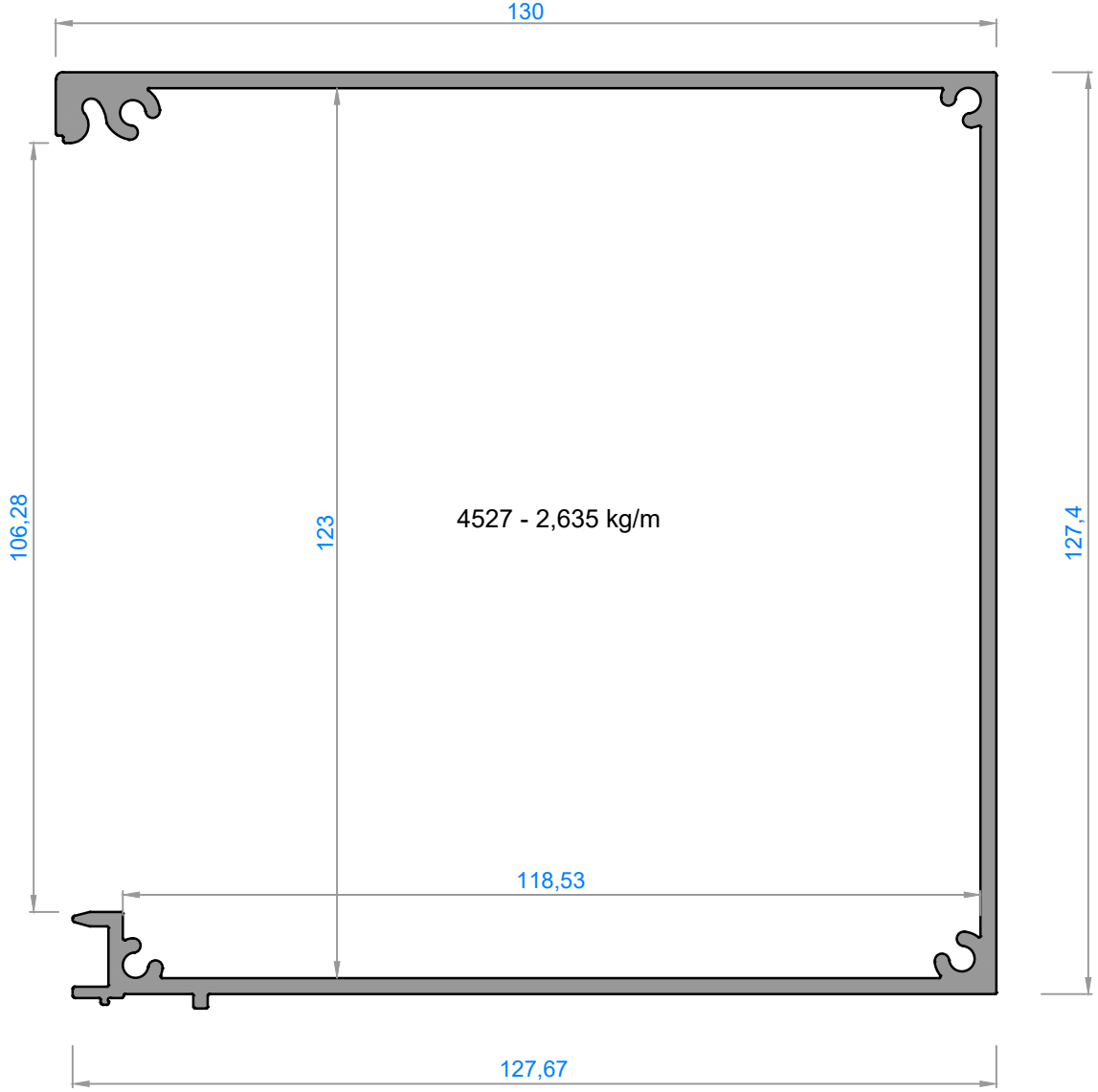

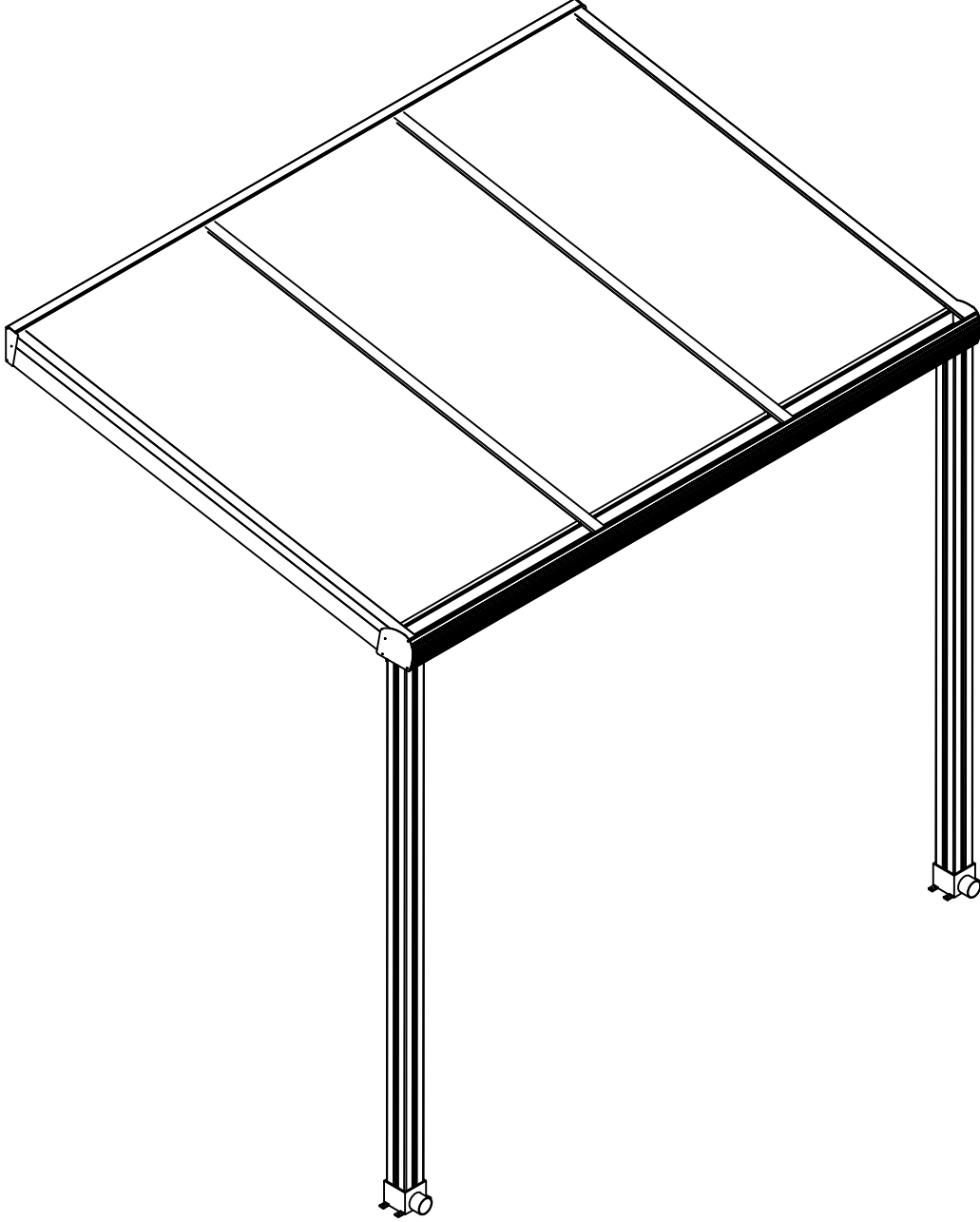

FC-160 KIŞ BAHÇESİ SİSTEMLERİ

FC-160 WINTER GARDEN SYSTEMS

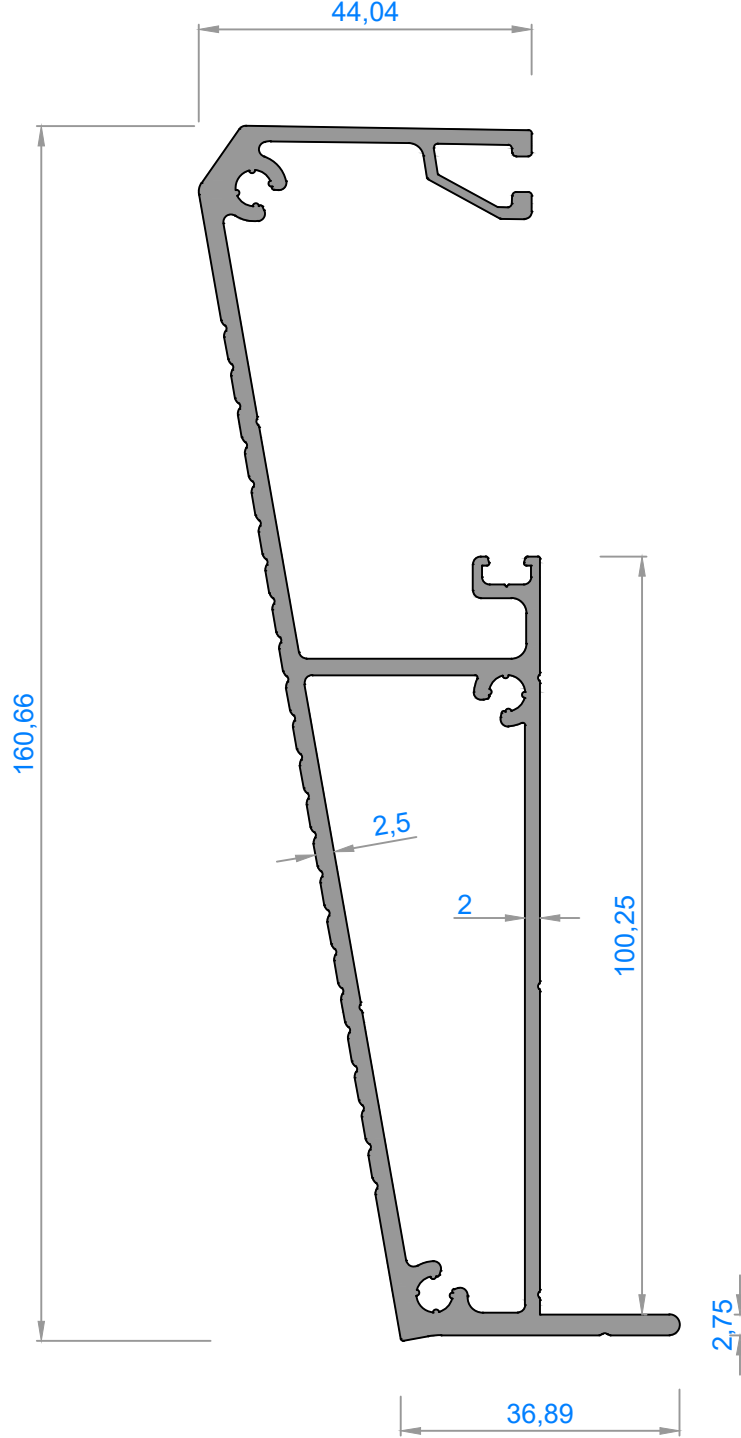

Sistem Kodu : FC50-6035

Ağırlık (kg/mt): 2,608

Statik J_x (cm⁴): 281,90

Statik J_y (cm⁴): 16,50

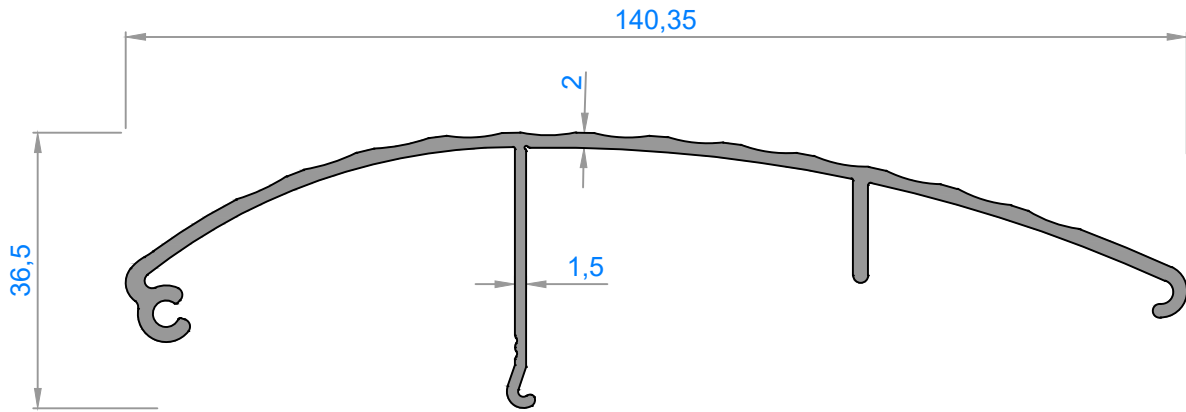
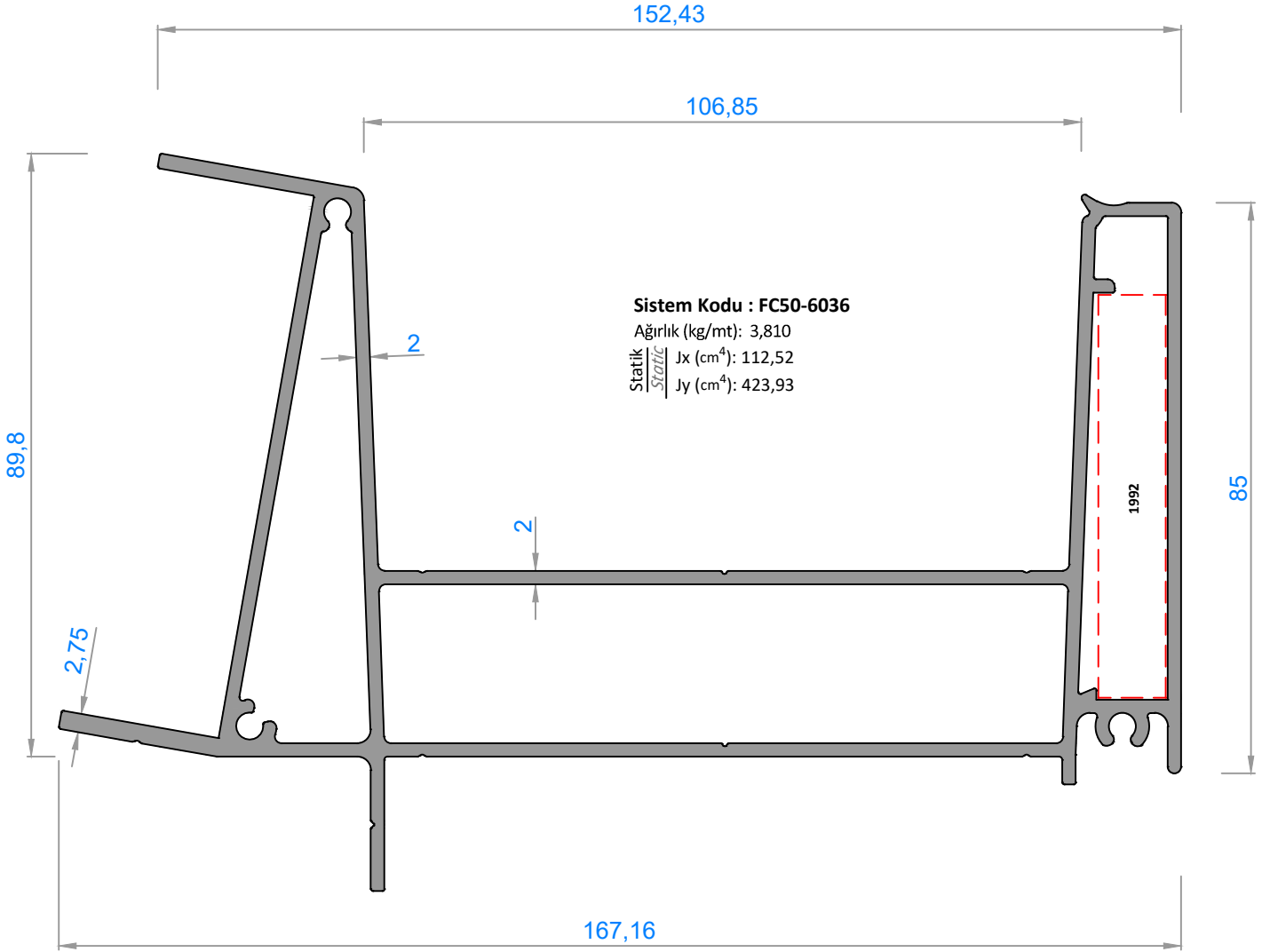

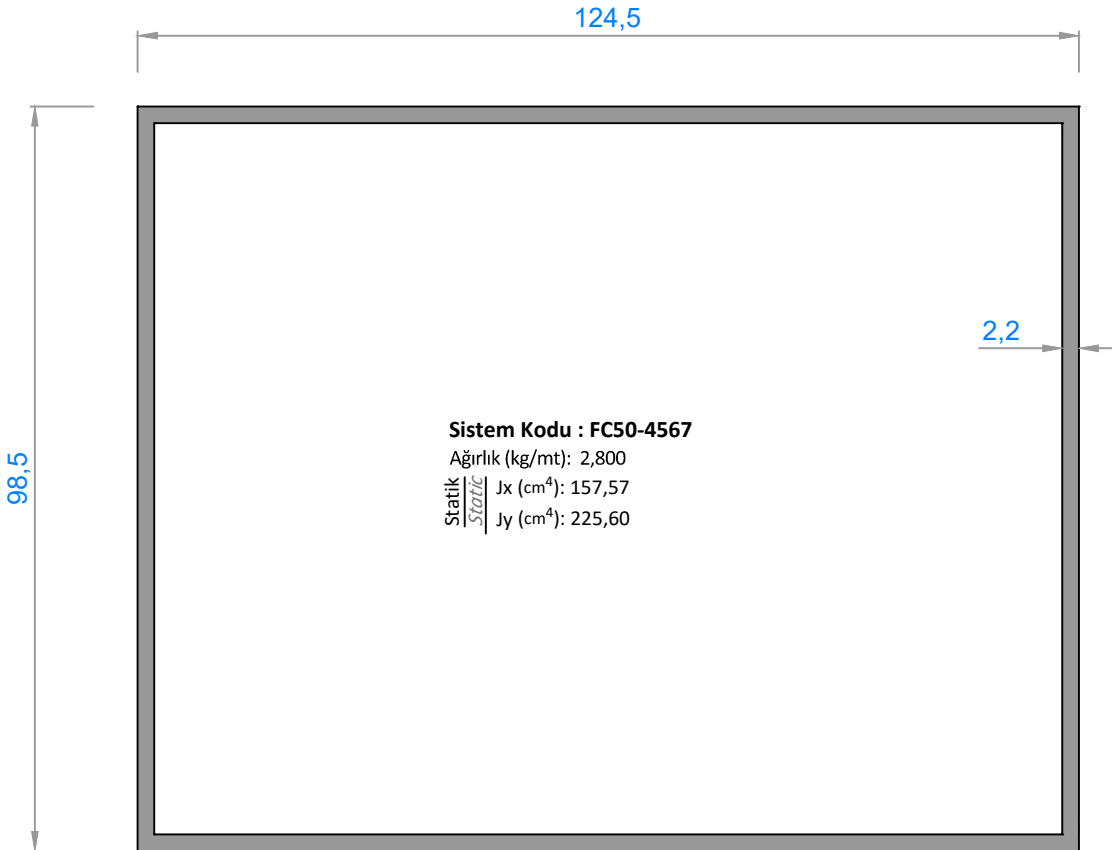
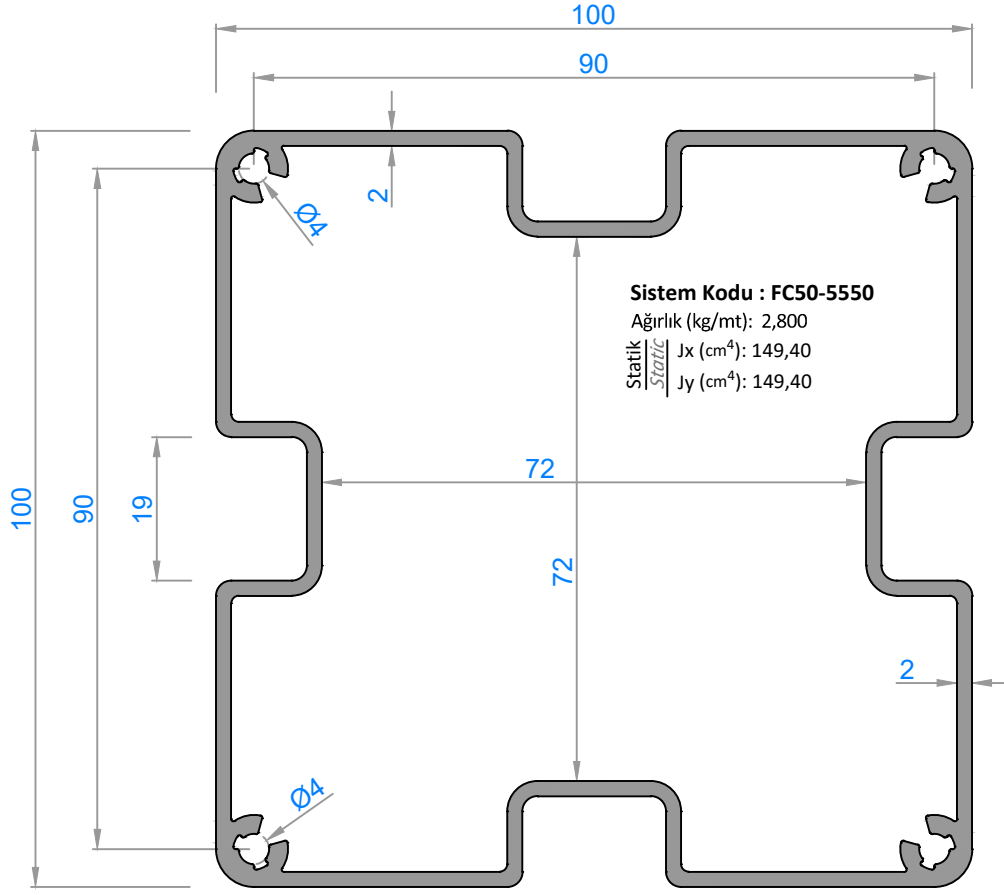

DÜŞEY TAŞIYICI PROFİLLER

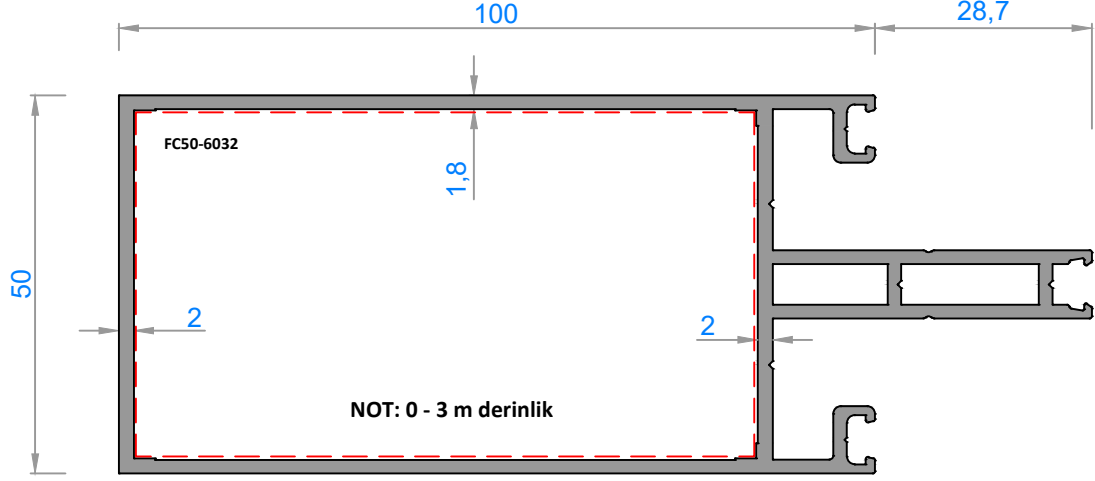

Sistem Kodu : FC50-6001

Ağırlık (kg/mt): 2,034

Statik J_x (cm⁴): 117,83

Statik J_y (cm⁴): 25,82

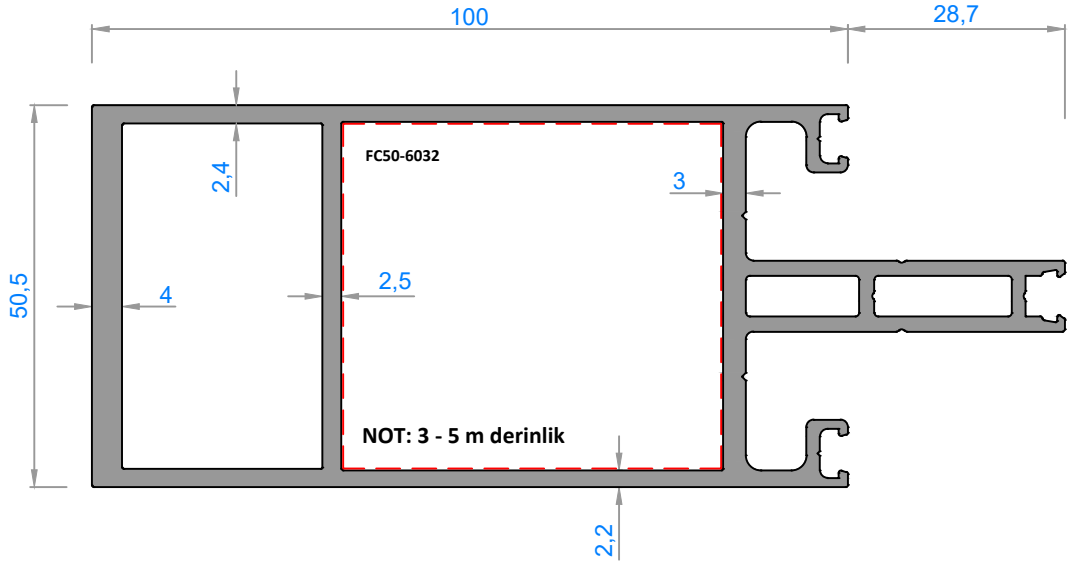

Sistem Kodu : FC50-6040

Ağırlık (kg/mt): 3,002

Statik J_x (cm⁴): 170,00

Statik J_y (cm⁴): 35,38

YATAY TAŞIYICI PROFİLLER

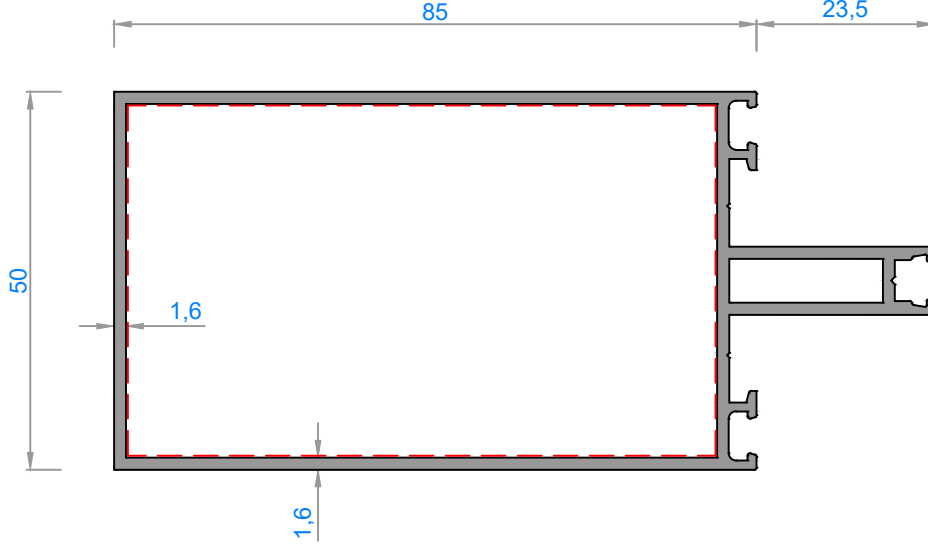

Sistem Kodu : FC50-6006

Ağırlık (kg/mt): 1,436

Statik J_x (cm⁴): 64,54

Statik J_y (cm⁴): 19,10

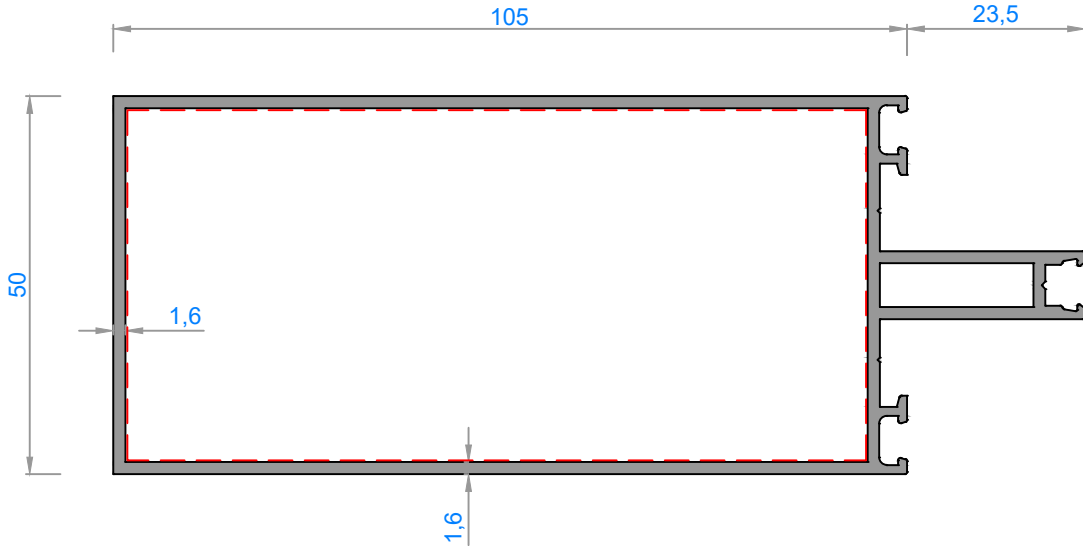

Sistem Kodu : FC50-6007

Ağırlık (kg/mt): 1,609

Statik J_x (cm⁴): 103,18

Statik J_y (cm⁴): 22,85

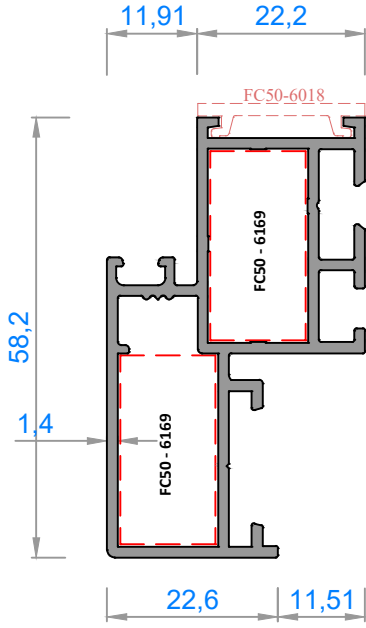

Sistem Kodu : FC50-6012

Ağırlık (kg/mt): 0,905

Statik
Statik Jx (cm⁴): 10,94
Jy (cm⁴): 2,77

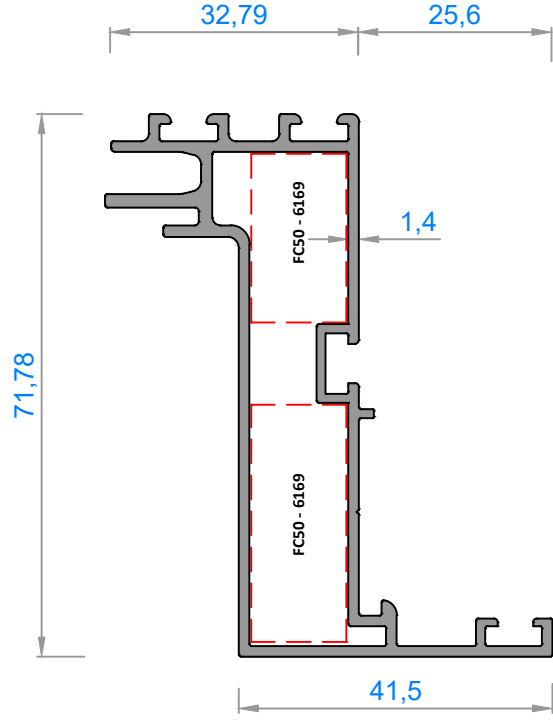

Sistem Kodu : FC50-6013

Ağırlık (kg/mt): 1,066

Statik
Statik Jx (cm⁴): 28,77
Jy (cm⁴): 3,70

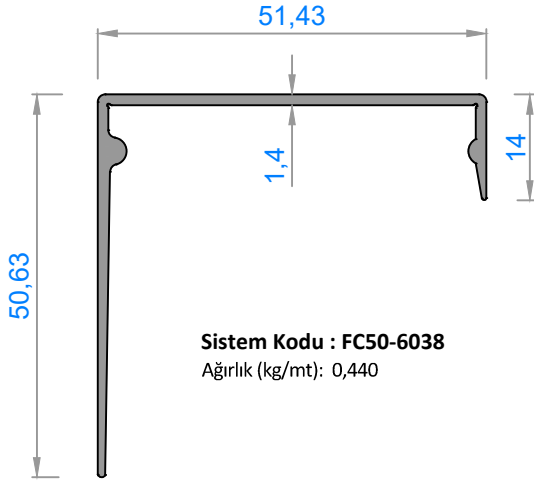

Sistem Kodu : FC50-6038

Ağırlık (kg/mt): 0,440

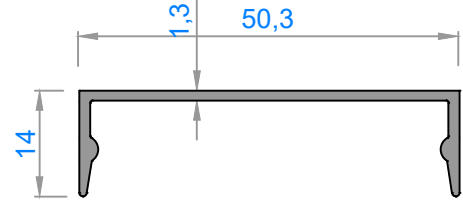

Sistem Kodu : FC50-6024

Ağırlık (kg/mt): 0,290

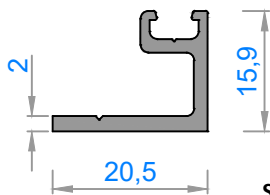

Sistem Kodu : FC50-6039

Ağırlık (kg/mt): 0,226

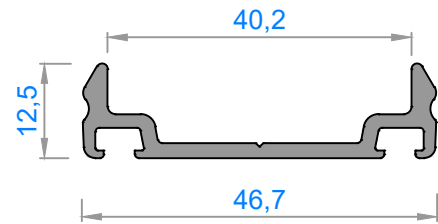

Sistem Kodu : FC50-6022

Ağırlık (kg/mt): 0,410

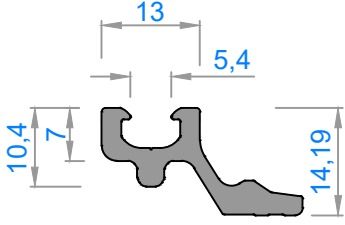

Sistem Kodu : FC50-6026
Ağırlık (kg/mt): 0,315

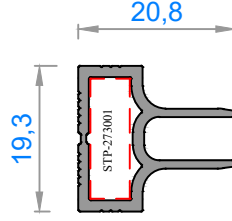

Sistem Kodu : FC50-6027
Ağırlık (kg/mt): 0,265

(siyah elokısalı)

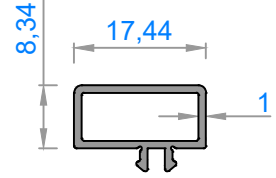

Sistem Kodu : FC50-6028
Ağırlık (kg/mt): 0,145

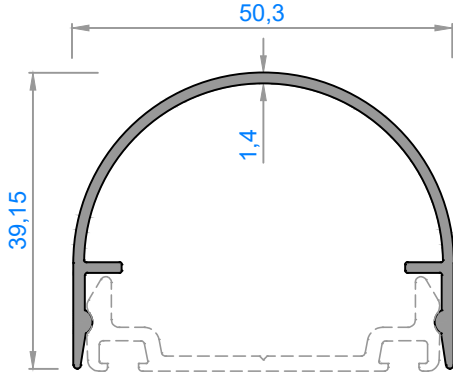

Sistem Kodu : FC50-6023
Ağırlık (kg/mt): 0,450

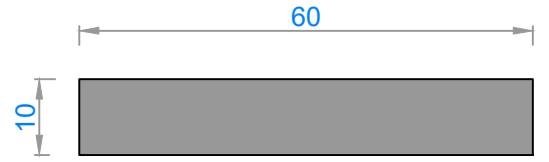

Sistem Kodu : FC50-1992
Ağırlık (kg/mt): 1,630

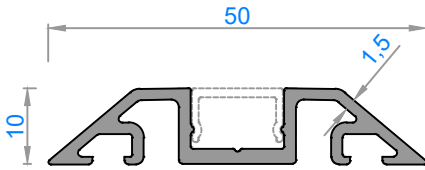

Sistem Kodu : FC50-6041
Ağırlık (kg/mt): 0,413
Statik J_x (cm⁴): 1,50
Statik J_y (cm⁴): 2,86

(-YATAY TAŞIYICI KAPAK-)

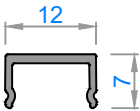

3560 - 0,070 kg/m

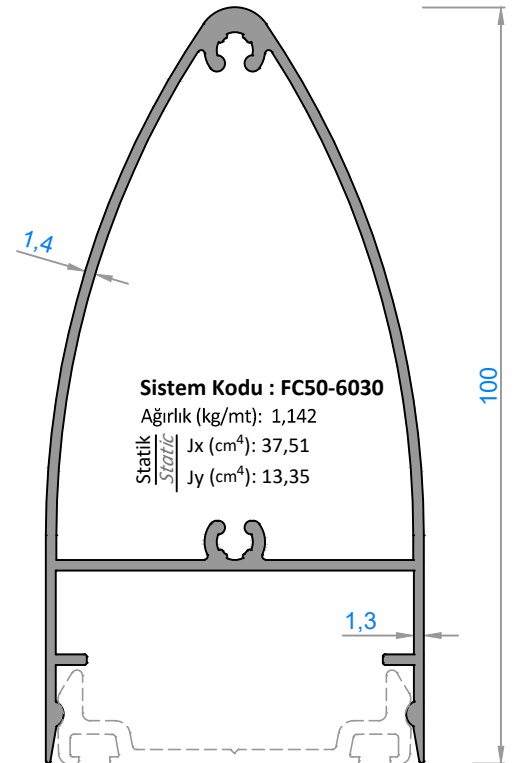

Sistem Kodu : FC50-6030
Ağırlık (kg/mt): 1,142
Statik J_x (cm⁴): 37,51
Statik J_y (cm⁴): 13,35

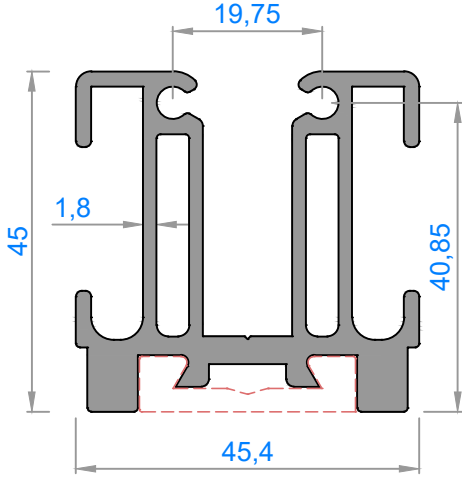

Sistem Kodu : FC50-6032

Ağırlık (kg/mt): 1,670

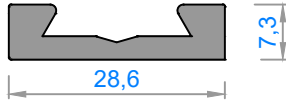

Sistem Kodu : FC50-6033

Ağırlık (kg/mt): 0,362

(-DÜŞEY TAŞIYICI BAĞLANTI KESİM ÖLÇÜLERİ -)

PROFİL PROFILE	* U * BAĞLANTI PROFİLİ	* U * CONNECTION PROFILE	KESİM ÖLÇÜSÜ CUTTING SIZE
	PROFİL KODU / PROFILE CODE	AKSESUAR KODU / ACCESSORY CODE	
FC50-6001	FC50-6032	FC50-6032 - 81,6	81,6 mm
FC50-6040	FC50-6032	FC50-6032 - 50	50 mm

(-YATAY TAŞIYICI BAĞLANTI KESİM ÖLÇÜLERİ -)

PROFİL PROFILE	* U * BAĞLANTI PROFİLİ	* U * CONNECTION PROFILE	KESİM ÖLÇÜSÜ CUTTING SIZE
	PROFİL KODU / PROFILE CODE	AKSESUAR KODU / ACCESSORY CODE	
FC50-6006	(FC50-6032) + (FC50-6033)	(FC50-6032) + (FC50-6033) - 77,3	77,3 mm
FC50-6007	(FC50-6032) + (FC50-6033)	(FC50-6032) + (FC50-6033) - 97,3	97,3 mm

KÖŞE TAKOZLARI (CORNER CLEATS)

Nr	L m	AKS. KODU ACS. CODE	KESİM ÖLÇÜSÜ CUTTING SIZE
FC50-6012	FC50 - 6169	FC50 - 6169-25,0	25,0 mm
	FC50 - 6169	FC50 - 6169-25,0	25,0 mm
FC50-6013	FC50 - 6169	FC50 - 6169-22,29	22,29 mm
	FC50 - 6169	FC50 - 6169-31,39	31,39 mm

Sistem Kodu : FC50 - 6169

Ağırlık (kg/mt): 2,220

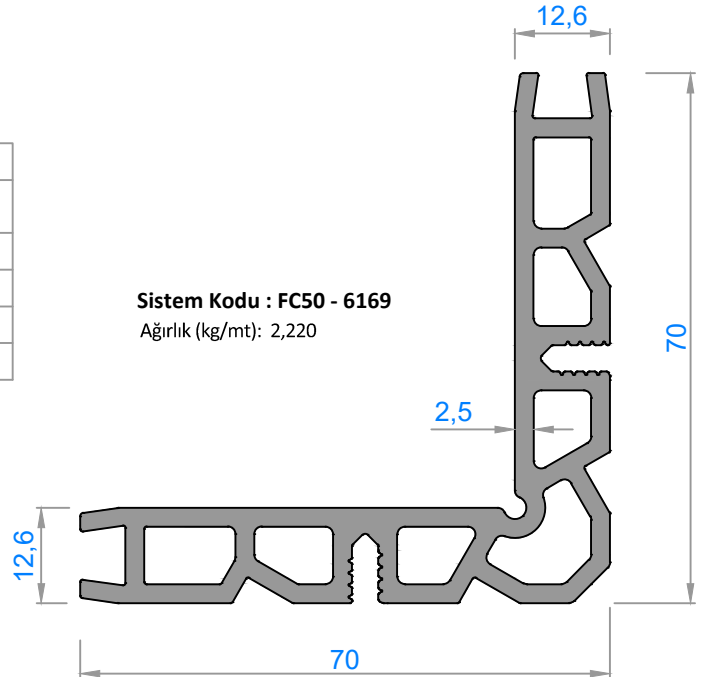

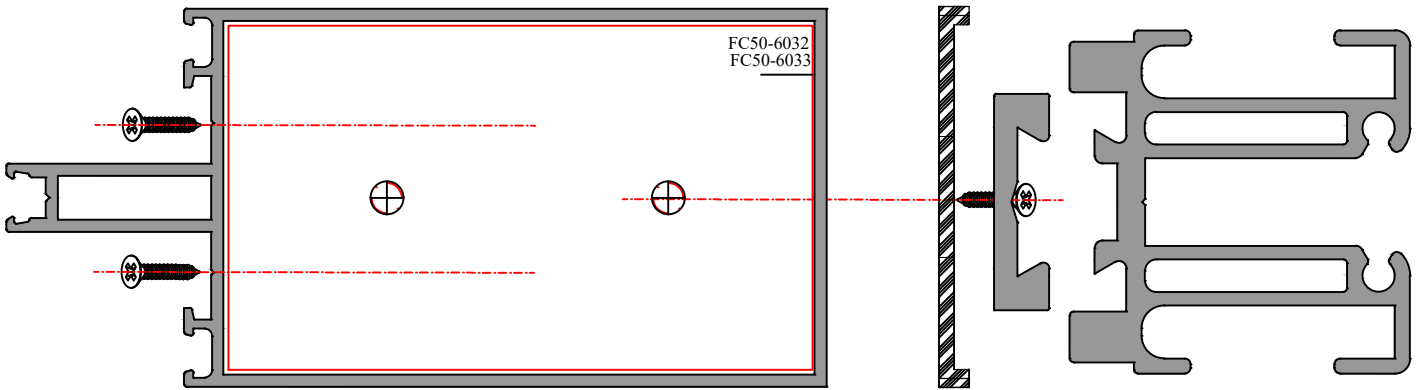
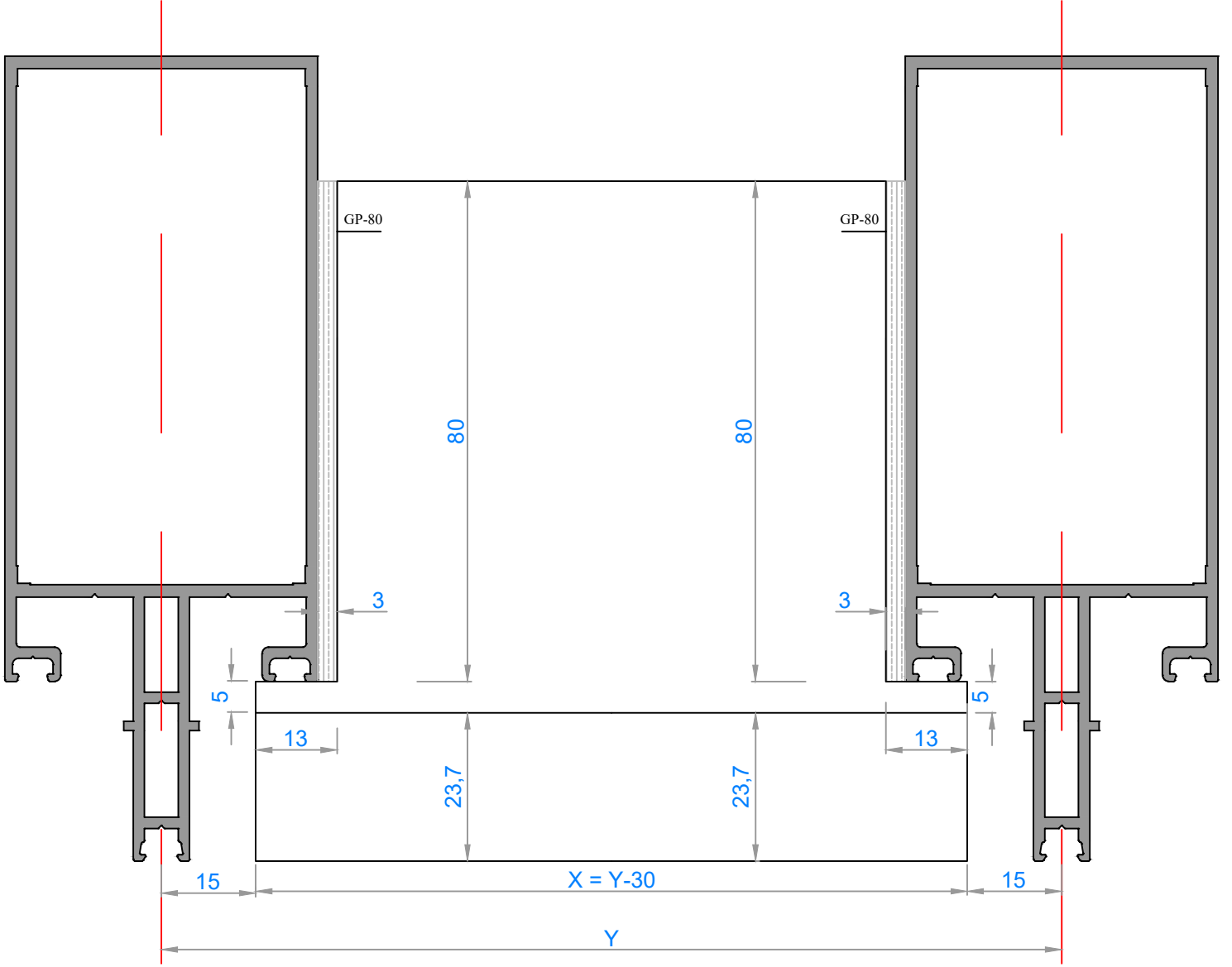

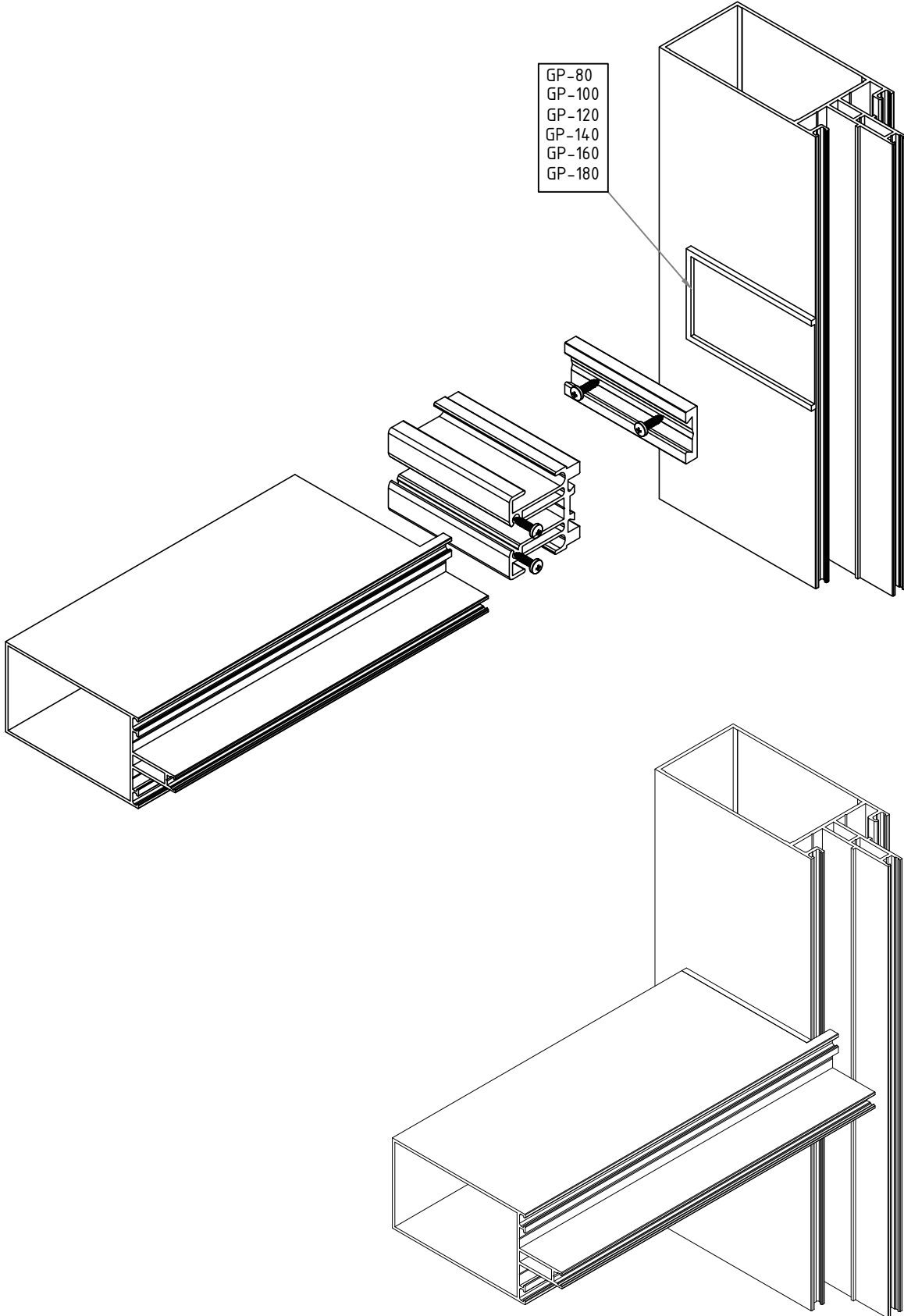



ZC02
EPDM FİTİL



FLT07
EPDM FİTİL



FLT08
EPDM FİTİL



FLT09
EPDM FİTİL

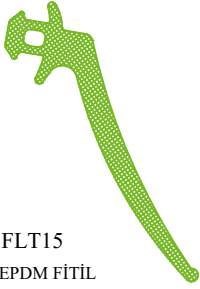

FLT15
EPDM FİTİL



FLT16
EPDM FİTİL

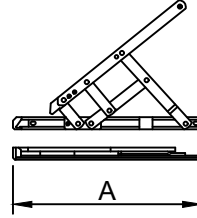

AKS18-XX
DİŞA AÇILIM MAKAS
TOP-HUNG WINDOW

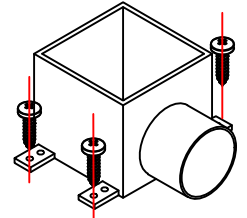

FC50-160
ALÜMİNYUM DİREK PAPUCU
ALUMINUM POLE LUGS

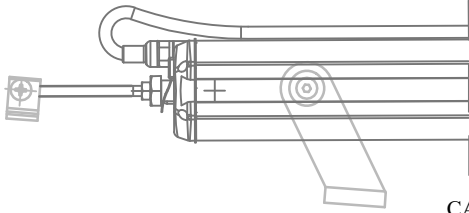

FC50-161
ÇATI MOTORU
ROOF ENGINE

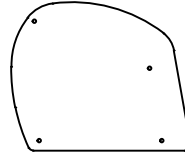

FC50-162
OLUK KAPAK
GUTTER COVER



FC50-163
DUVAR KAPAK
WALL COVER

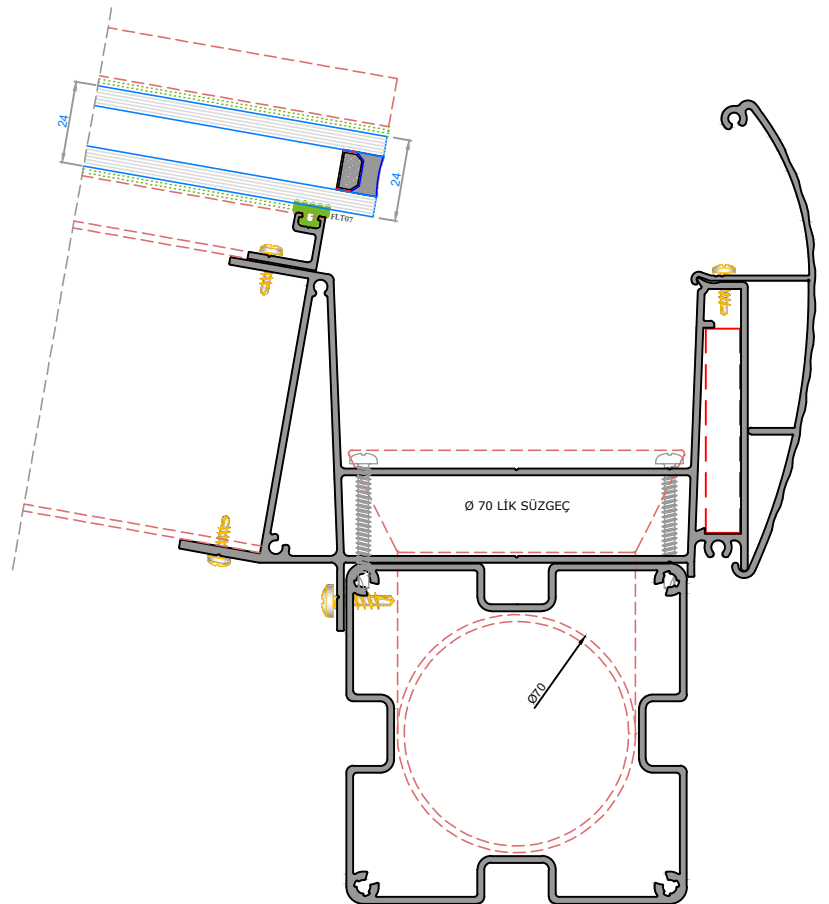
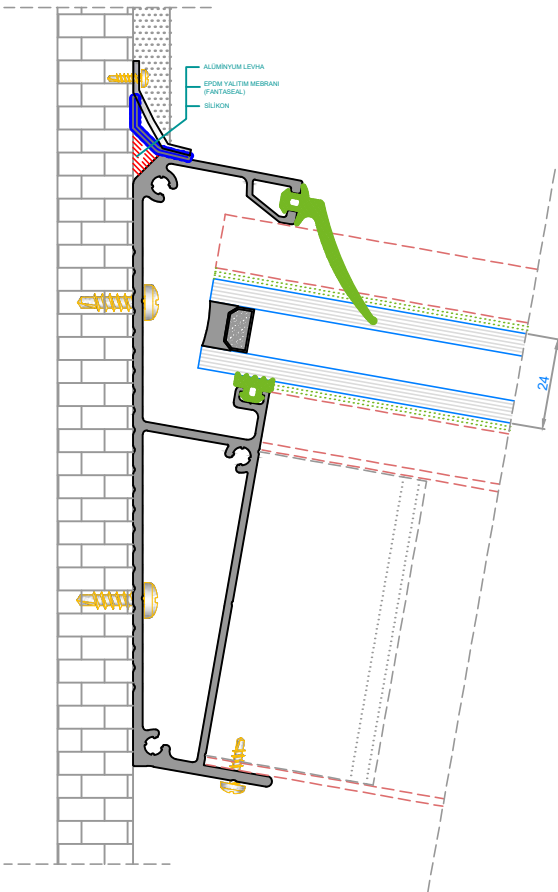

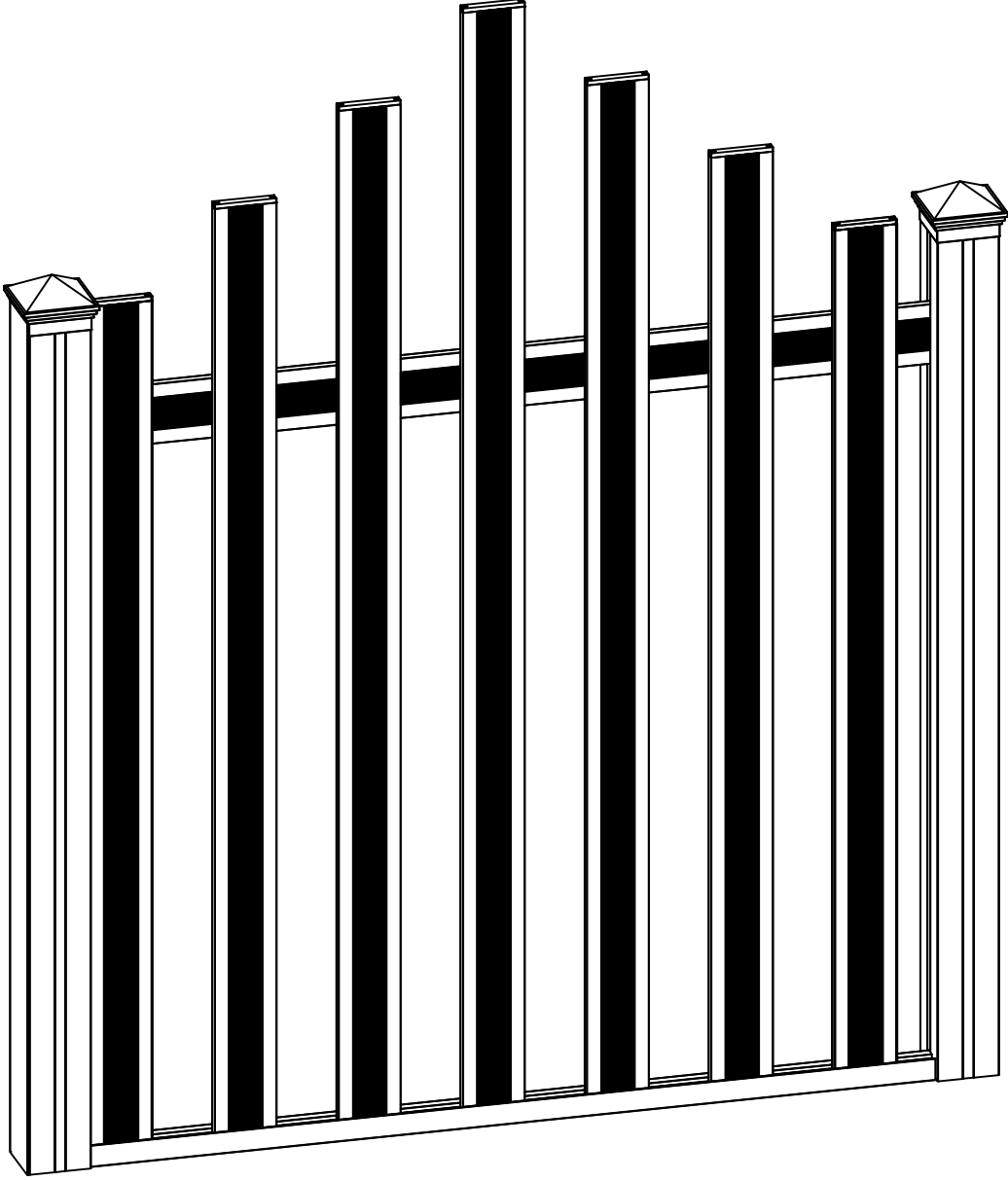

ÇİT SİSTEMLERİ / ALUFENCE SYSTEMS

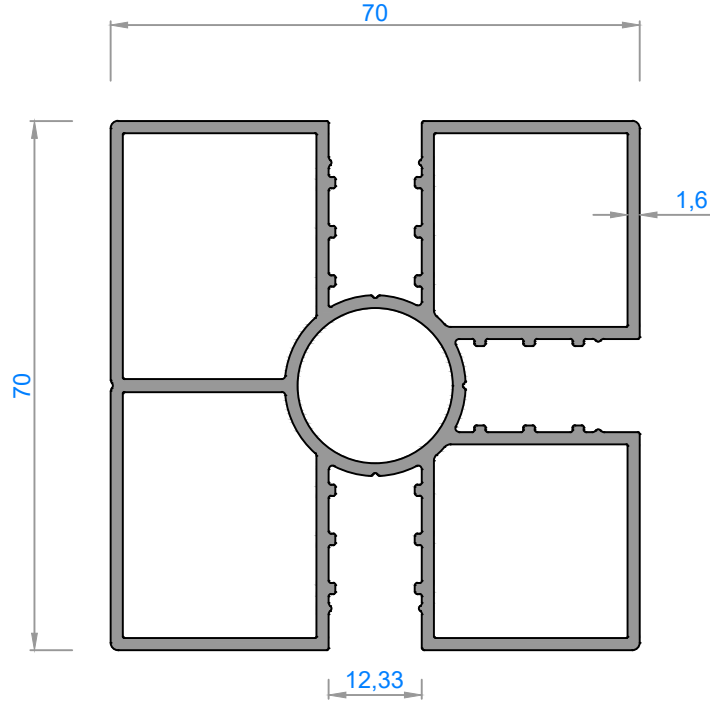

Sistem Kodu : 6182

Ağırlık (kg/mt): 2,136

Statik
Statik Jx (cm⁴): 39,13

Jy (cm⁴): 39,50

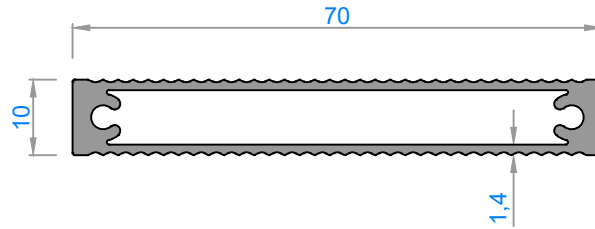

Sistem Kodu : 6183

Ağırlık (kg/mt): 0,623

Statik
Statik Jx (cm⁴): 13,70

Jy (cm⁴): 0,32

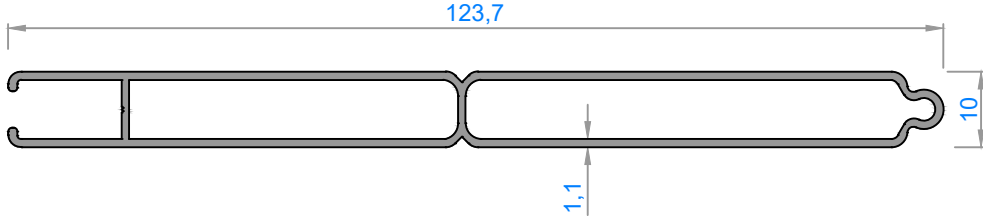

Sistem Kodu : 1324

Ağırlık (kg/mt): 0,800

Statik J_x (cm⁴): 38,50

Statik J_y (cm⁴): 0,53

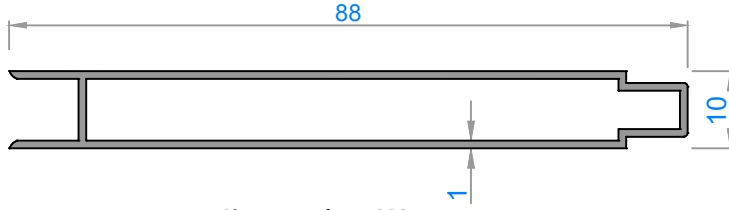

Sistem Kodu : 1083

Ağırlık (kg/mt): 0,520

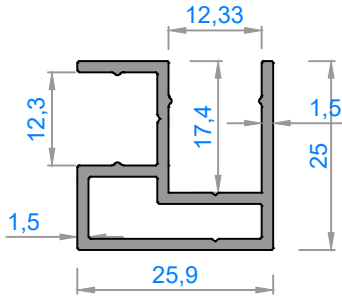

Sistem Kodu : 3814

Ağırlık (kg/mt): 0,450

Statik J_x (cm⁴): 1,07

Statik J_y (cm⁴): 1,23

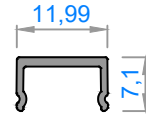

Sistem Kodu : 3560

Ağırlık (kg/mt): 0,067

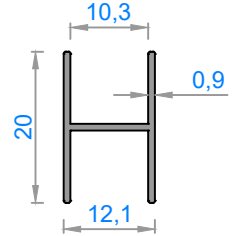

Sistem Kodu : 6184

Ağırlık (kg/mt): 0,123

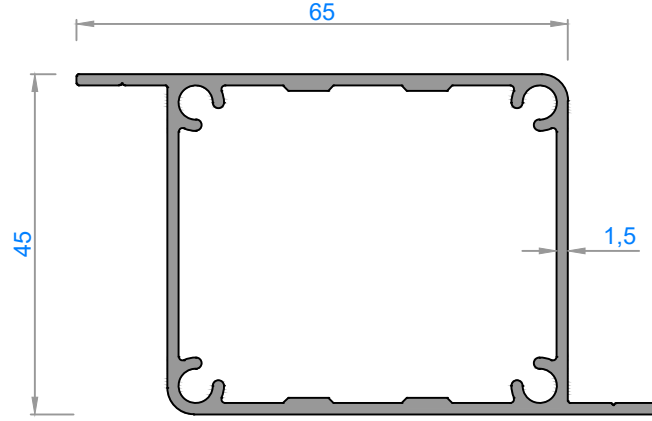

Sistem Kodu : 5868

Ağırlık (kg/mt): 1,021

Statik J_x (cm⁴): 11,72

J_y (cm⁴): 19,15

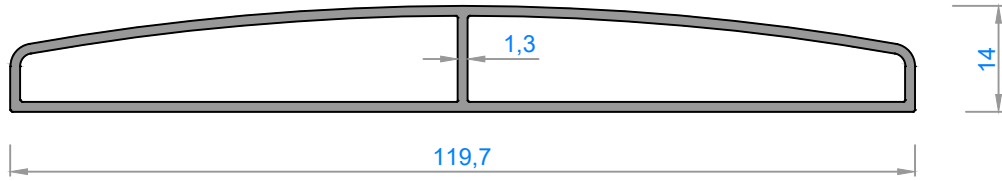

Sistem Kodu : 5867

Ağırlık (kg/mt): 0,924

Statik J_x (cm⁴): 42,22

J_y (cm⁴): 1,00

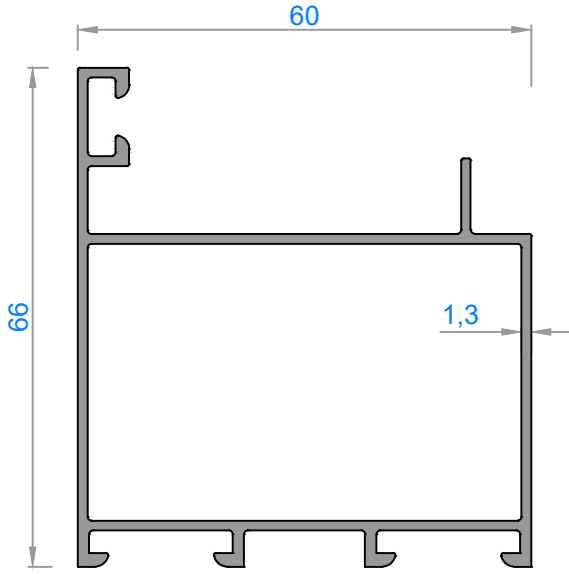

1157 - 0,975 kg/m

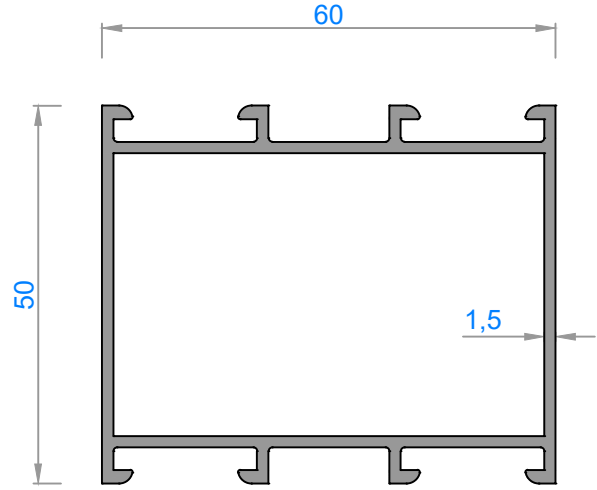

1158 - 1,033 kg/m

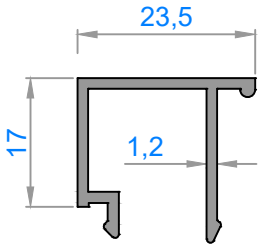

1151 - 0,232 kg/m

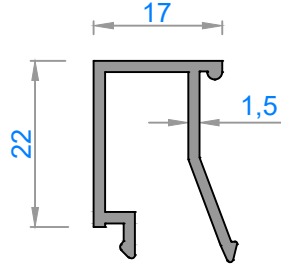

1152 - 0,298 kg/m

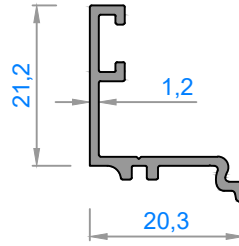

* 4502 - 0,192 kg/m

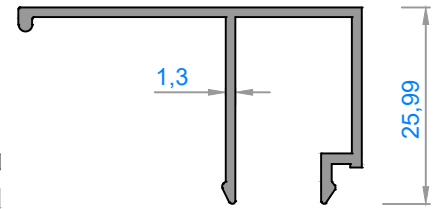

* 4503 - 0,361 kg/m

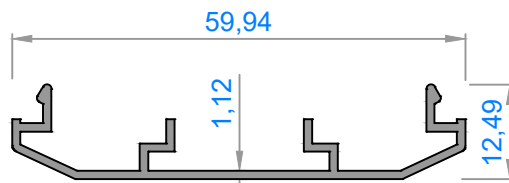

2580 - 0,324 kg/m

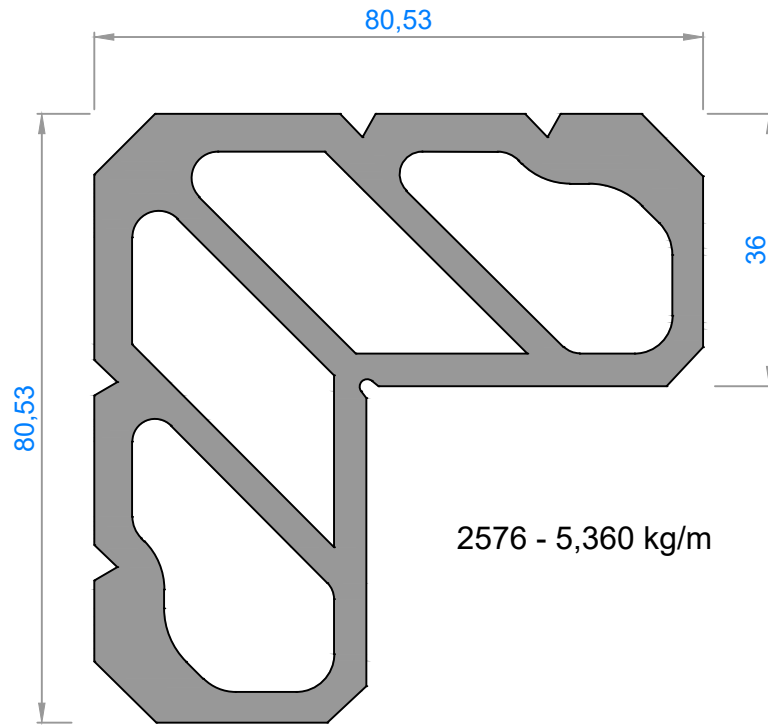
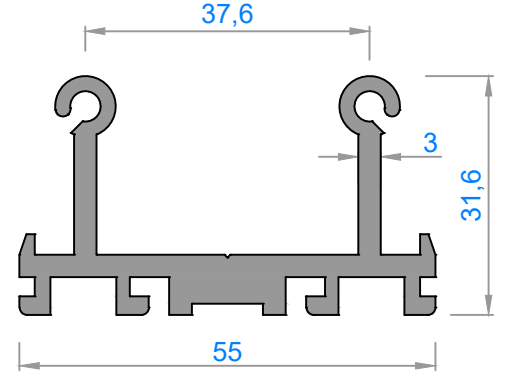
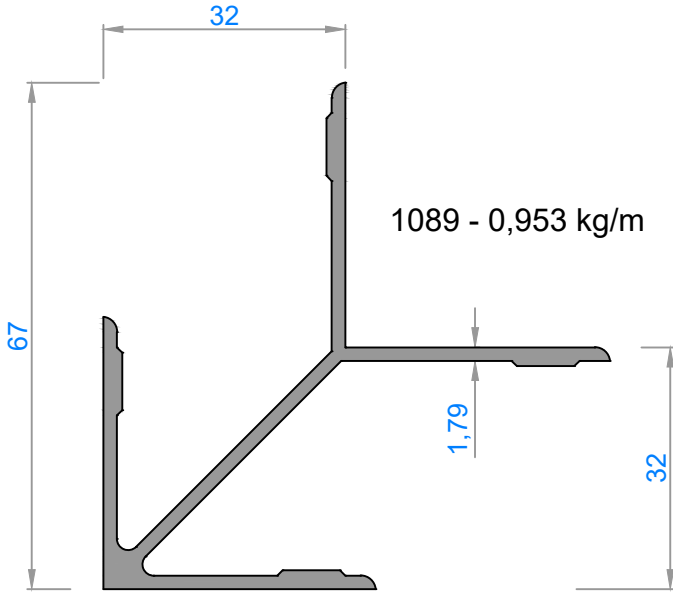

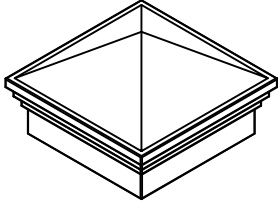

ÇP-3

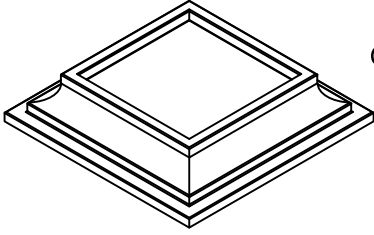

ÇP-4

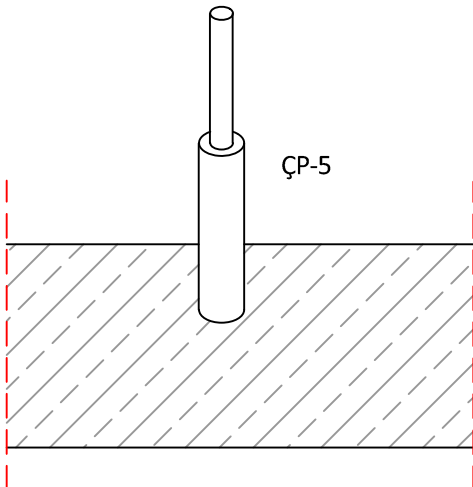
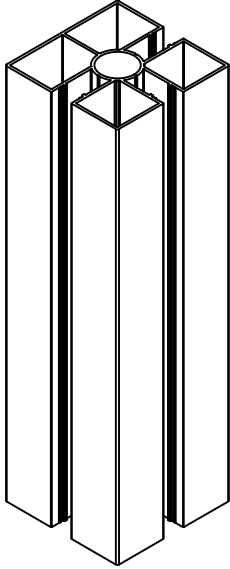

ÇP-5

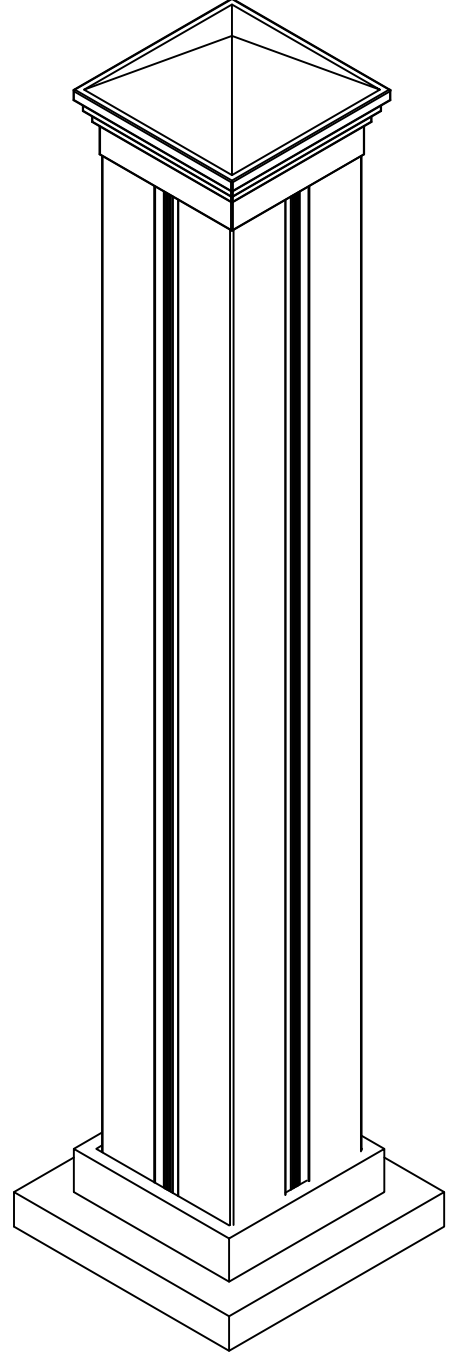

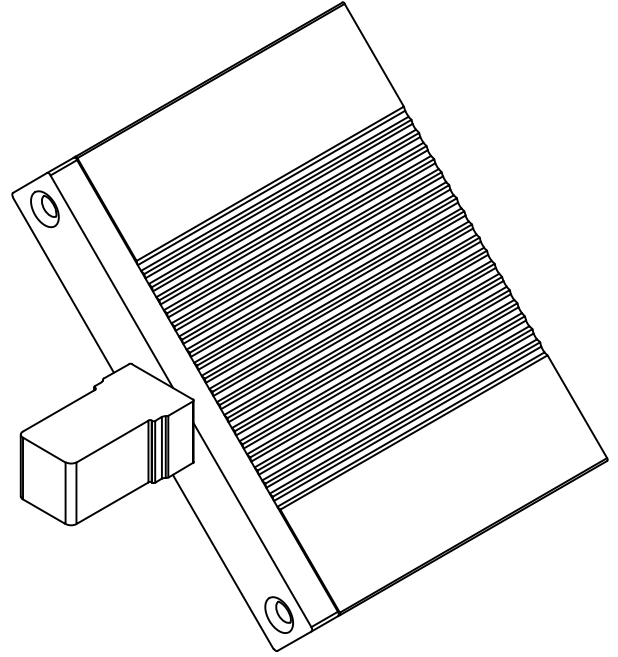
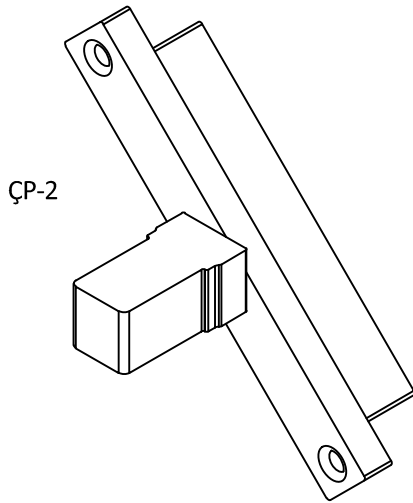
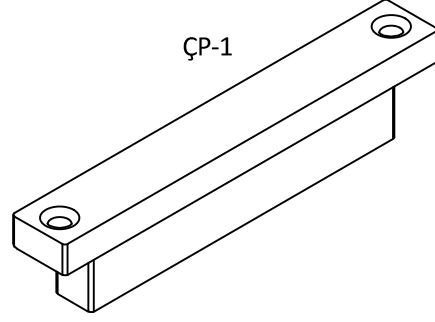
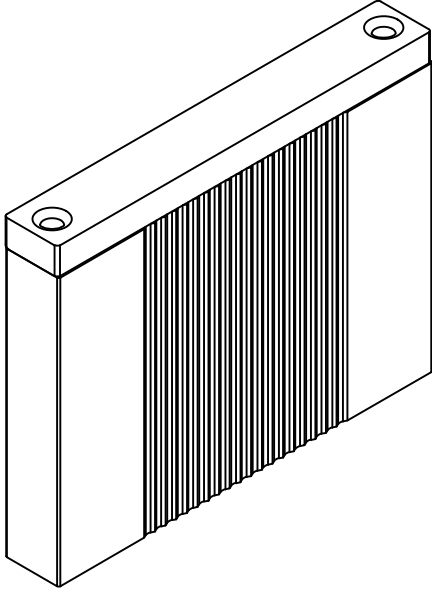

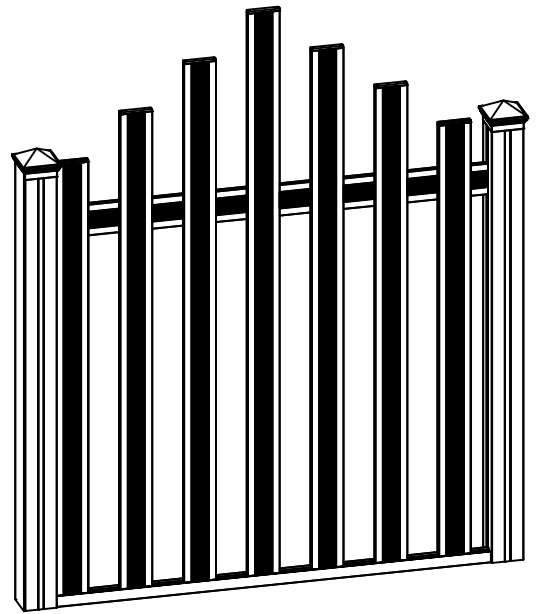
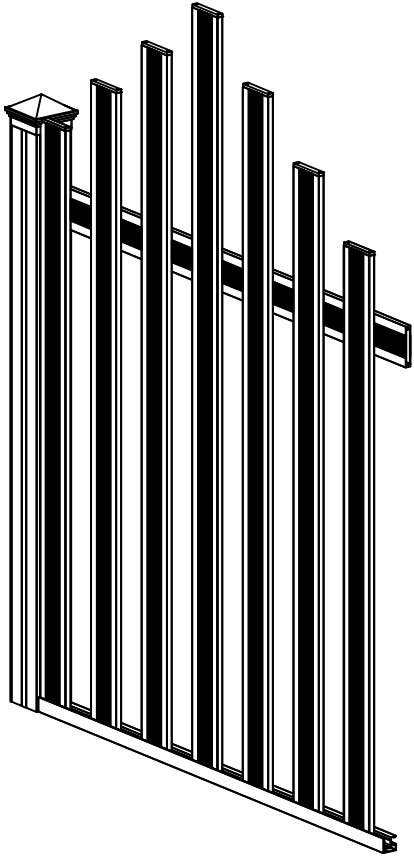
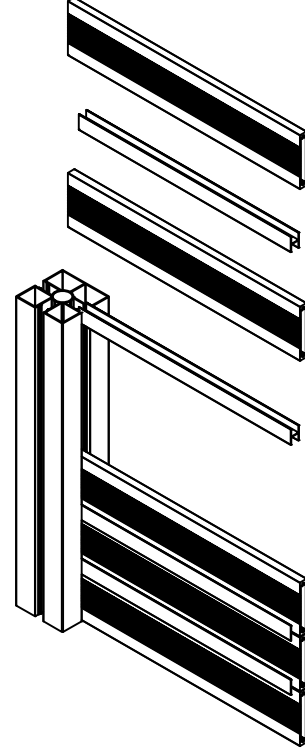
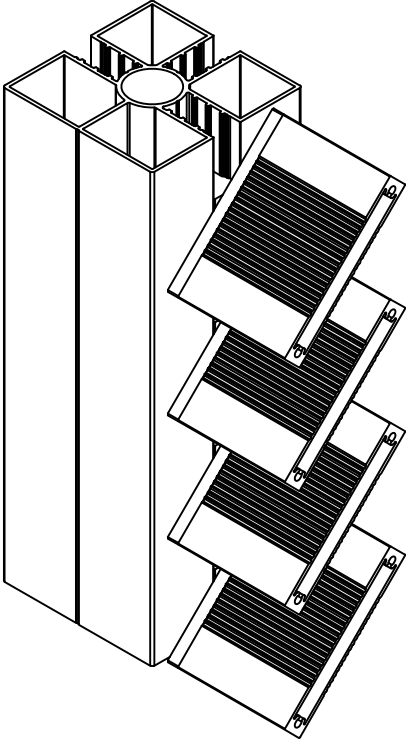

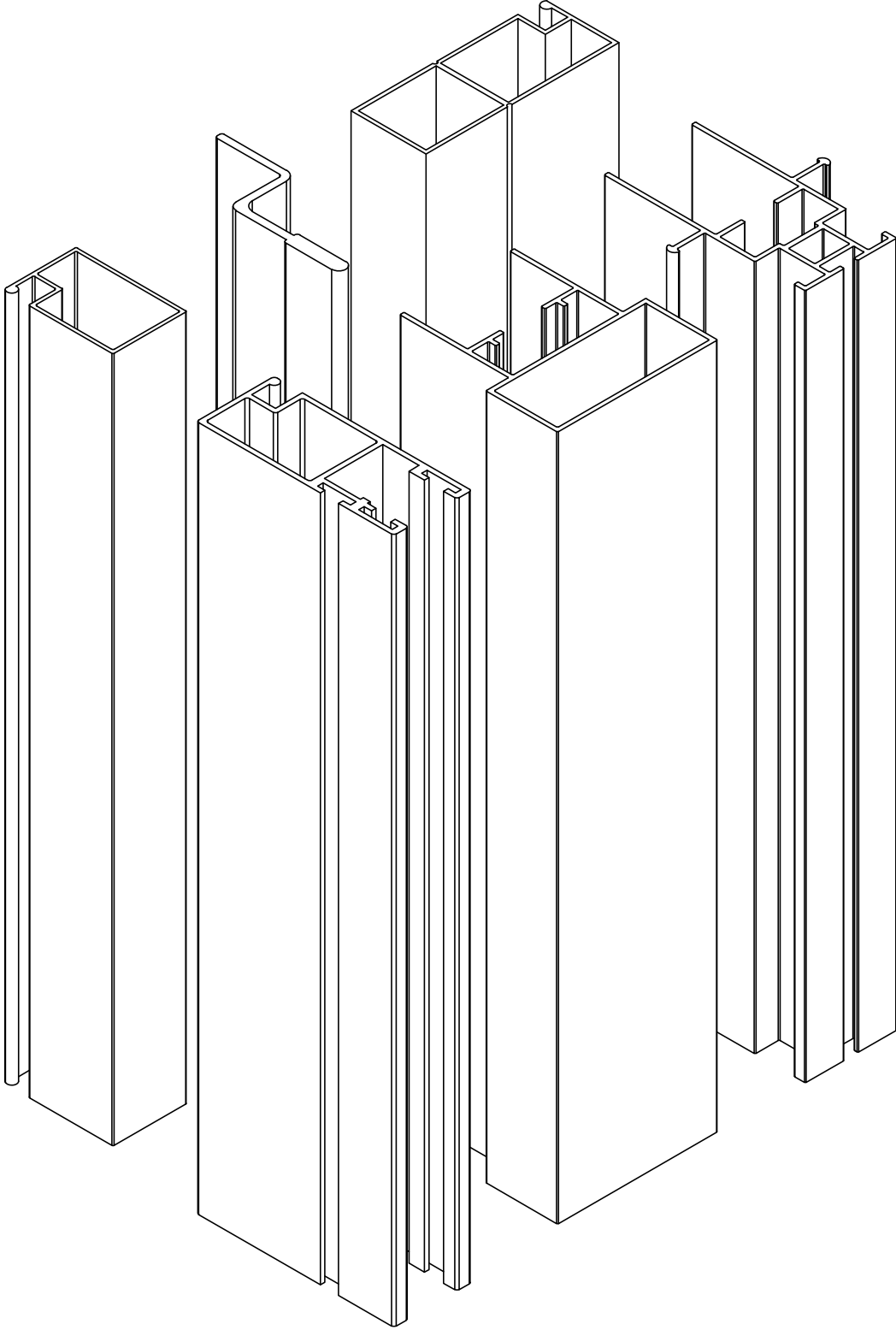

SİNEKLİK PROFİLLERİ / Flyscreen Profiles

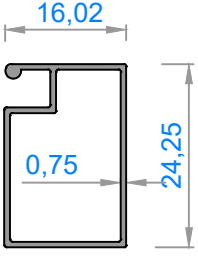

1725 - 0,176 kg/m

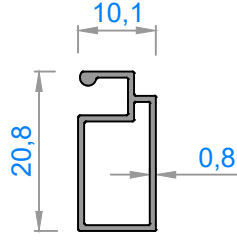

1727 - 0,143 kg/m

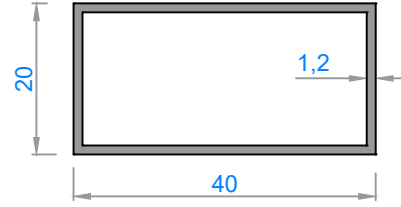

1031 - 0,374 kg/m

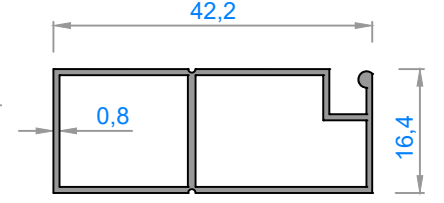

1770 - 0,304 kg/m

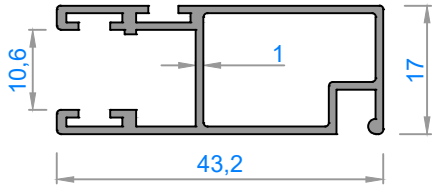

1141 - 0,407 kg/m

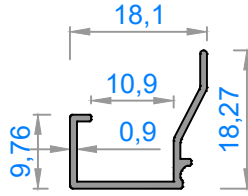

1990 - 0,111 kg/m

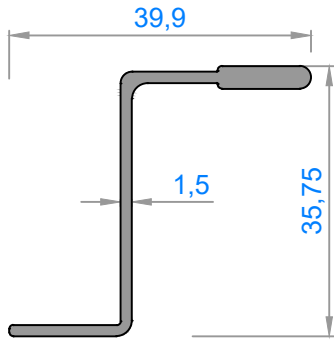
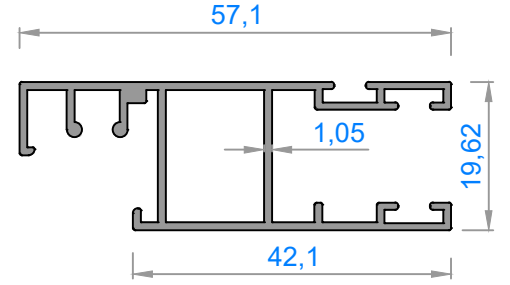

2448 - 0,345 kg/m

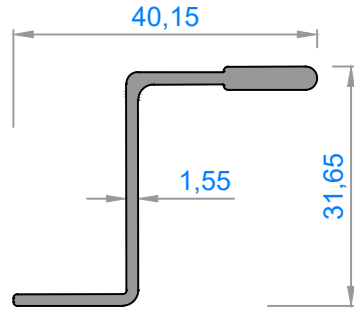

1143 - 0,322 kg/m

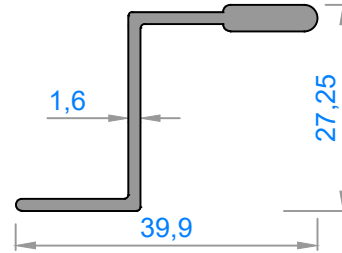

1768 - 0,338 kg/m

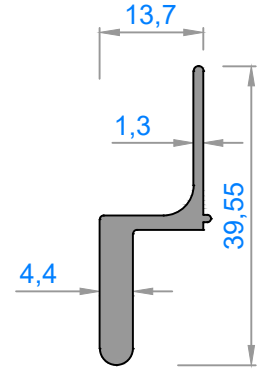

2099 - 0,359 kg/m

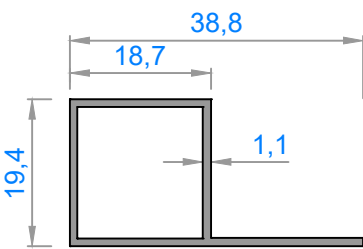

2076 - 0,260 kg/m

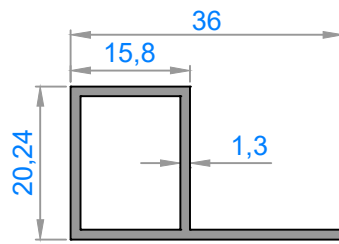

2295 - 0,306 kg/m

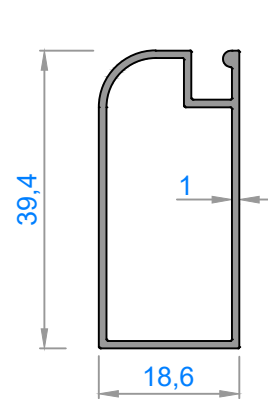

2266 - 0,320 kg/m

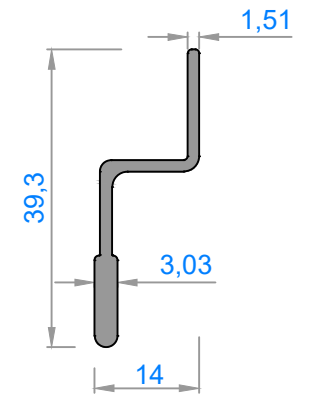

1142 - 0,257 kg/m

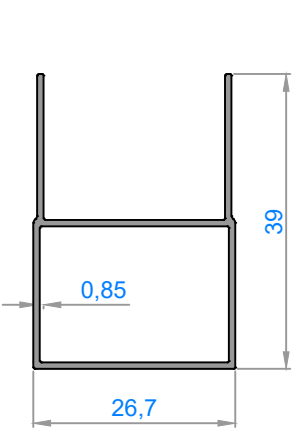

4464 - 0,295 kg/m

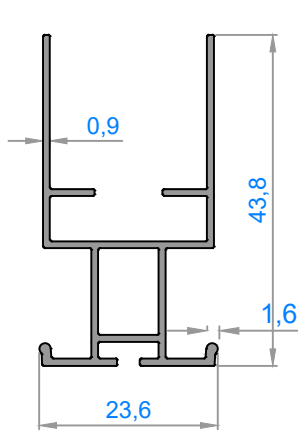

4465 - 0,375 kg/m

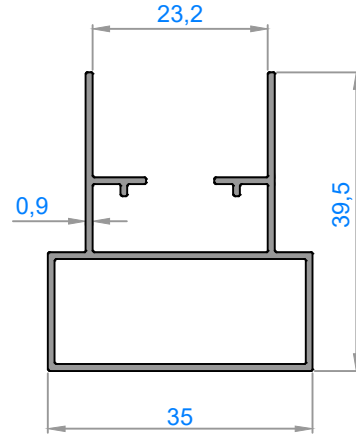

4473 - 0,397 kg/m

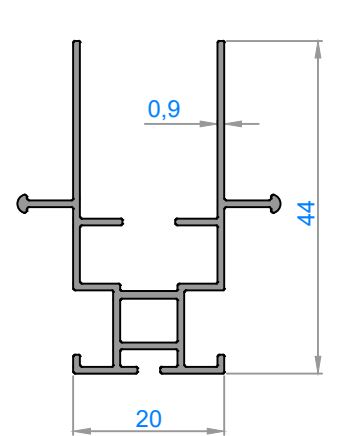

4474 - 0,395 kg/m

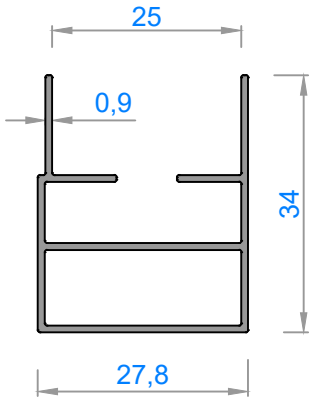

4223 - 0,336 kg/m

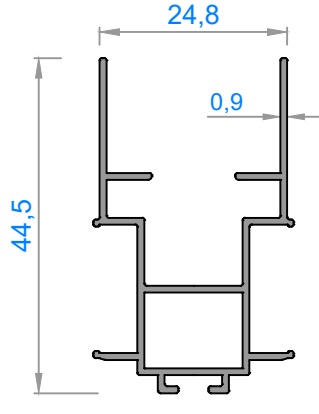

4224 - 0,373 kg/m

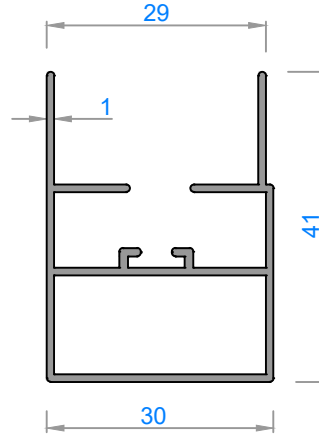

4252 - 0,453 kg/m

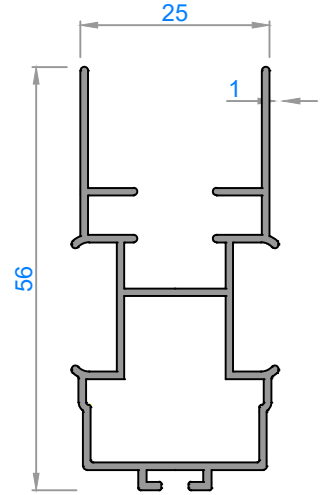

4253 - 0,524 kg/m

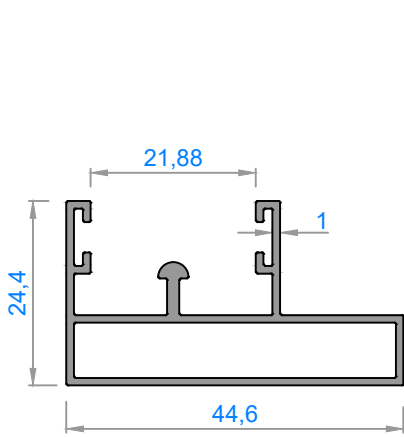

4701 - 0,446 kg/m

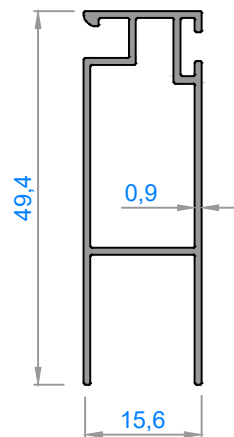

4700 - 0,344 kg/m

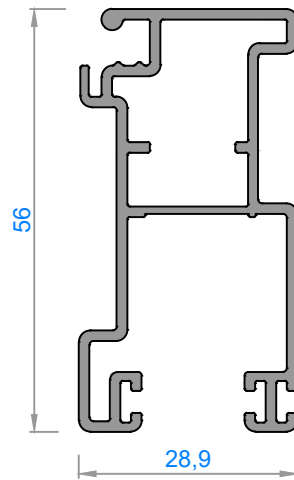

4731 - 0,800 kg/m

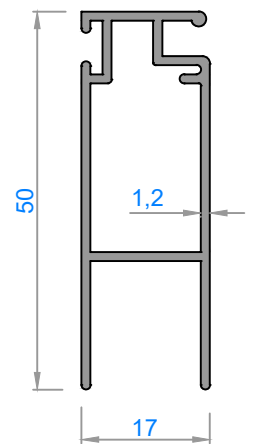

4867 - 0,470 kg/m

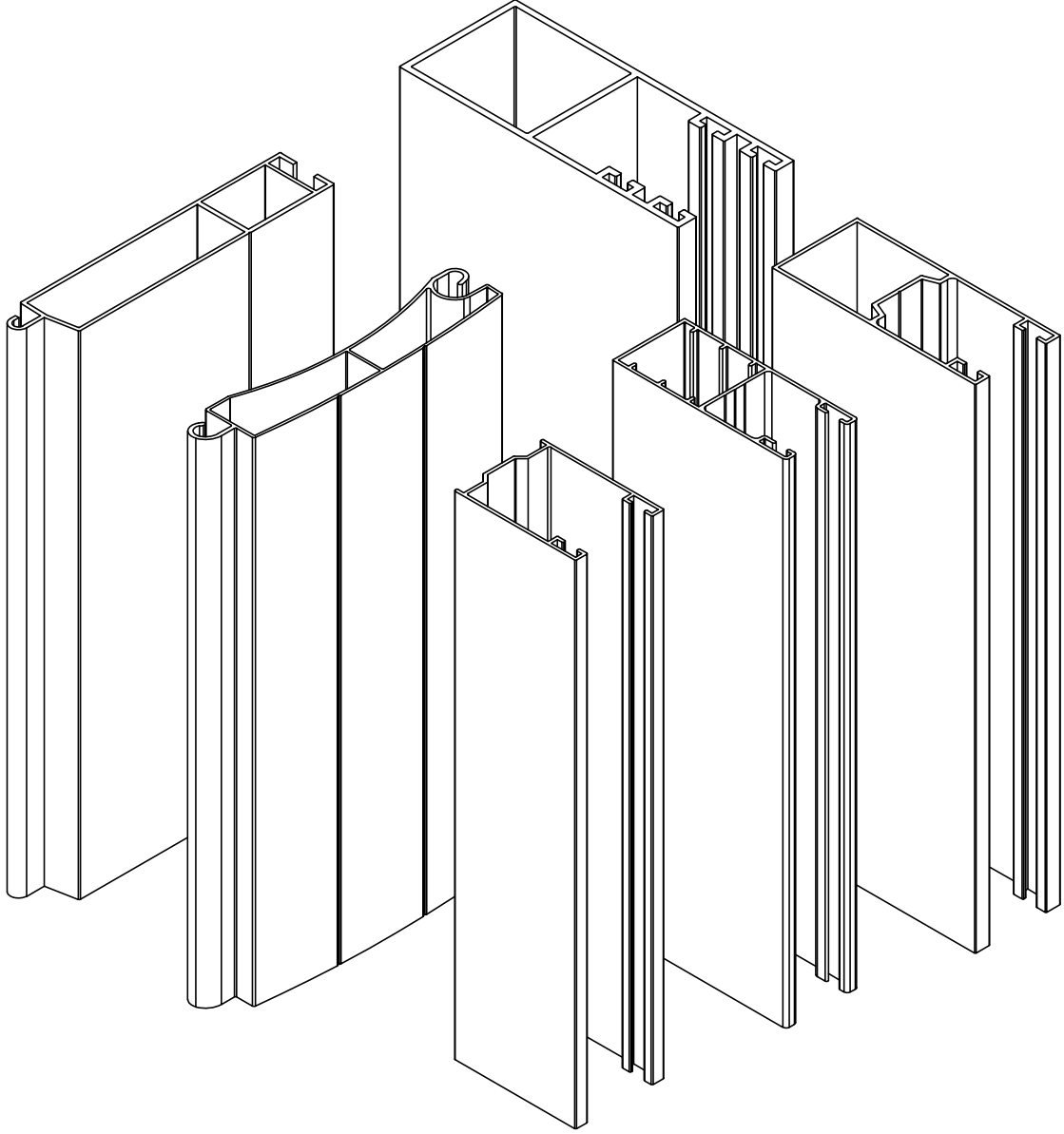

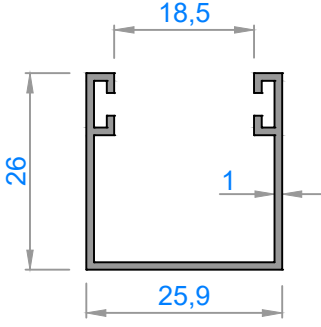

1099 - 0,252 kg/m

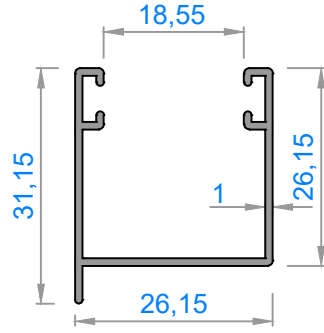

2161 - 0,263 kg/m

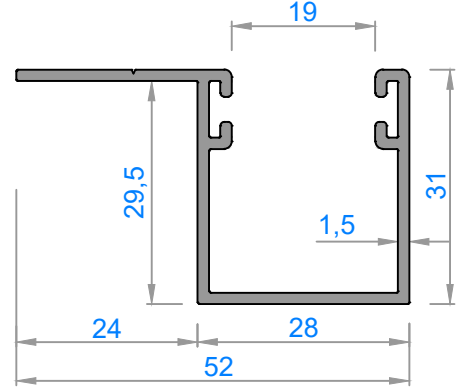

2317 - 0,531 kg/m

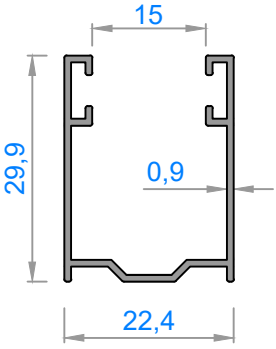

3884 - 0,245 kg/m

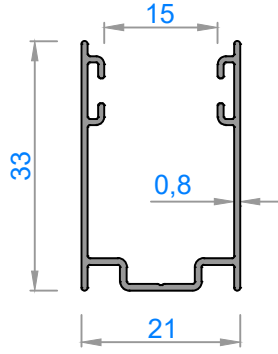

3334 - 0,240 kg/m

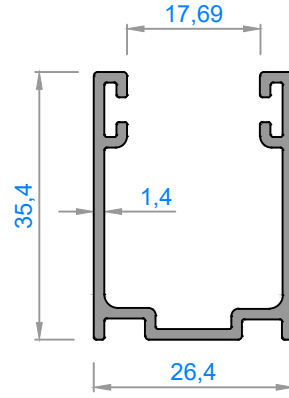

4727 - 0,455 kg/m

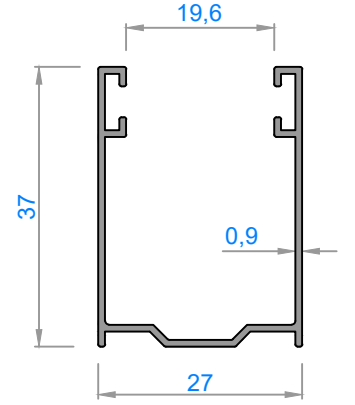

3888 - 0,292 kg/m

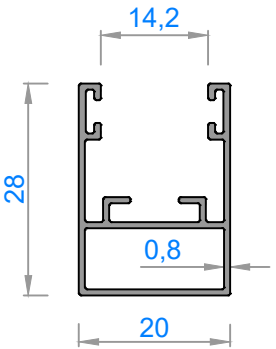

3625 - 0,265 kg/m

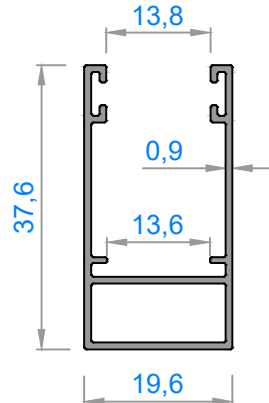

3624 - 0,315 kg/m

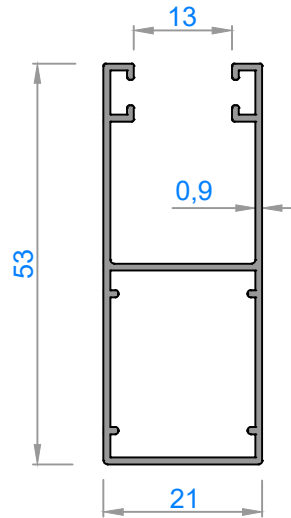

3885 - 0,405 kg/m

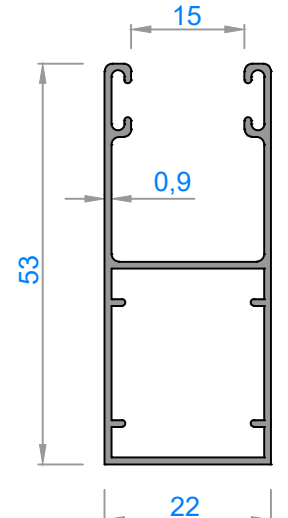

3059 - 0,420 kg/m

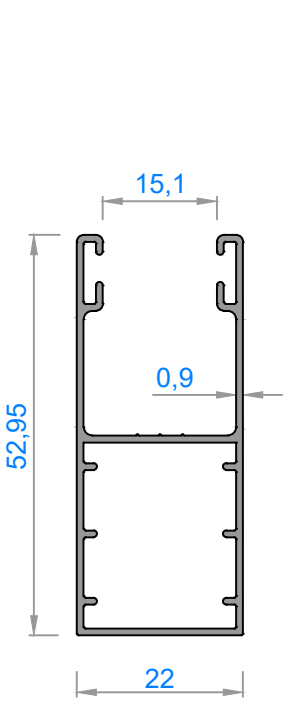

2255 - 0,430 kg/m

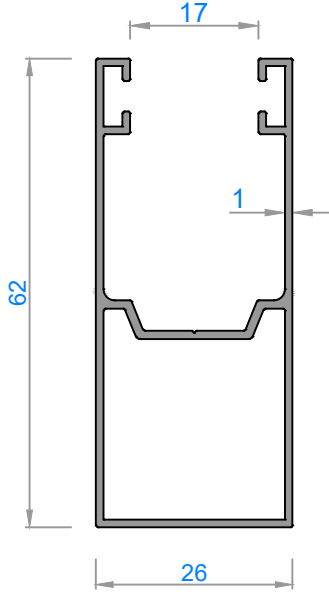

4730 - 0,555 kg/m

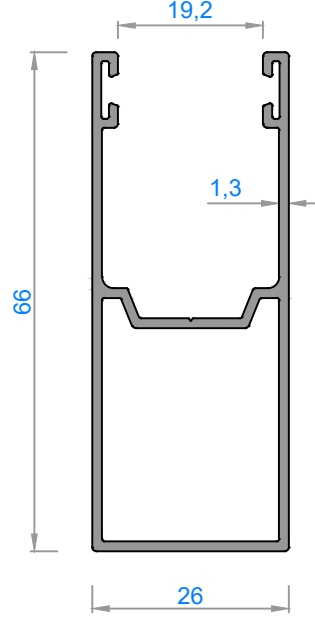

4729 - 0,700 kg/m

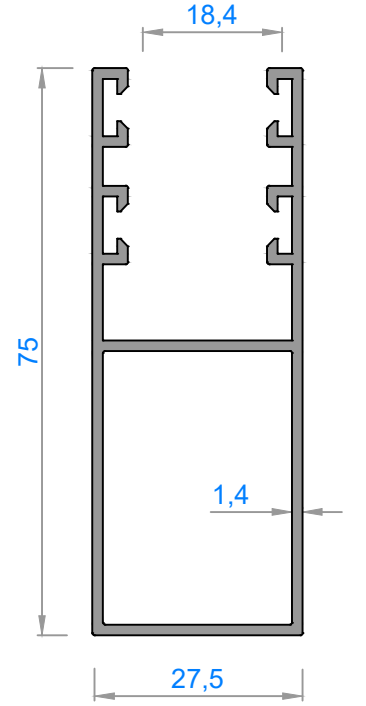

1500 - 0,910 kg/m

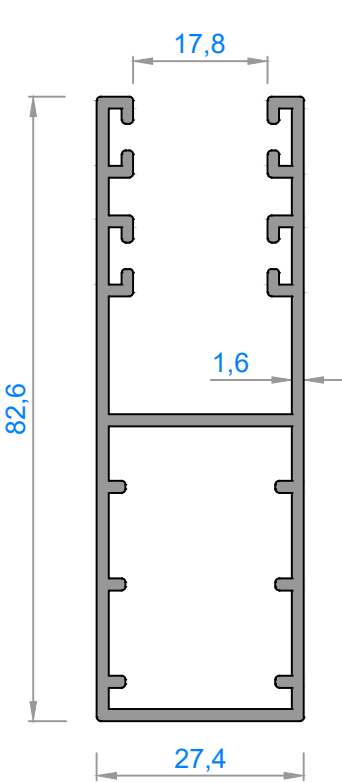

3396 - 1,155 kg/m

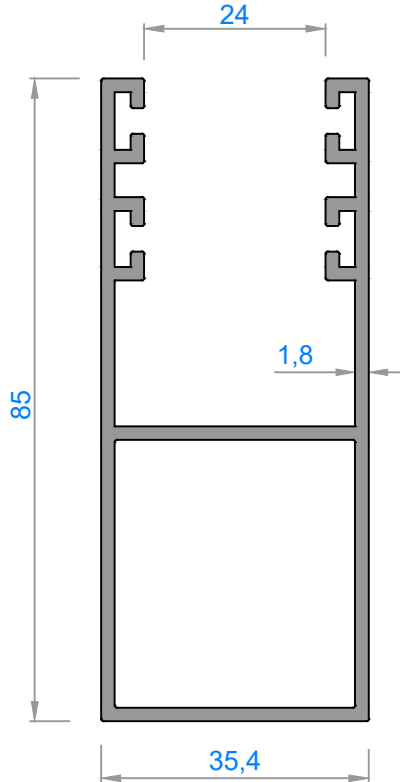

1501- 1,370 kg/m

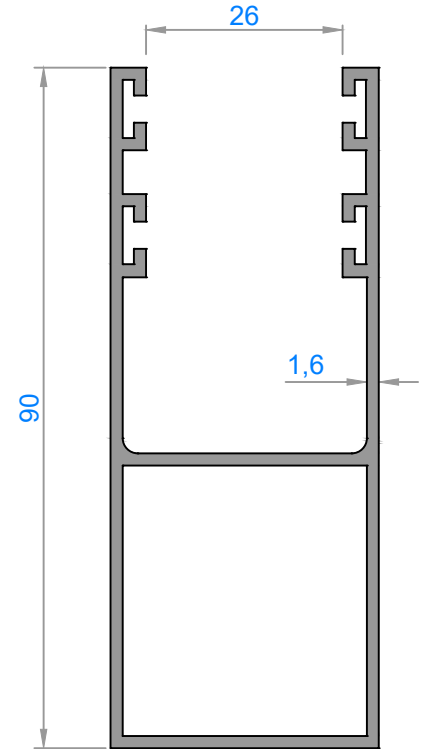

3072- 1,255 kg/m

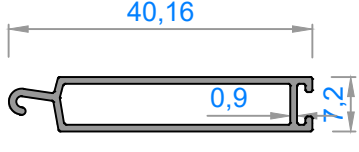

3626 - 0,222 kg/m

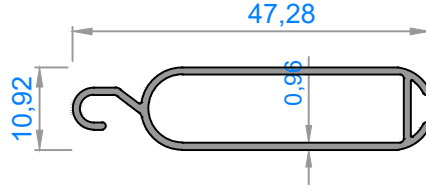

2162 - 0,280 kg/m

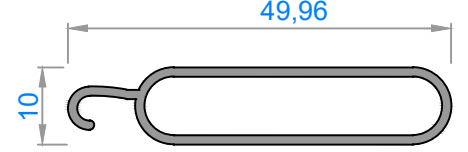

1100 - 0,335 kg/m

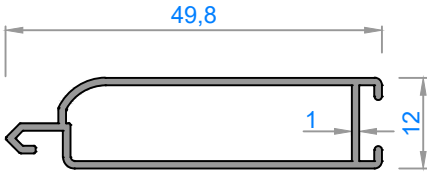

3137 - 0,320 kg/m

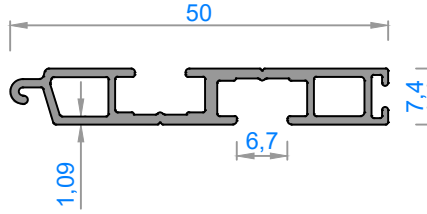

4728 - 0,350 kg/m

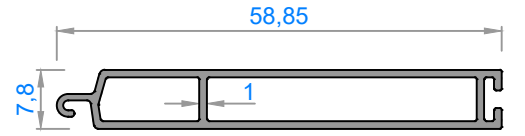

3376 - 0,366 kg/m

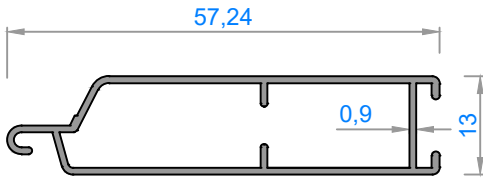

3891 - 0,347 kg/m

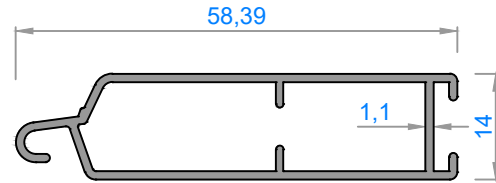

3050 - 0,435 kg/m

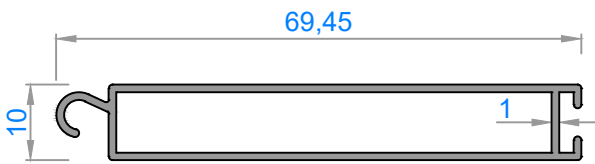

2588 - 0,428 kg/m

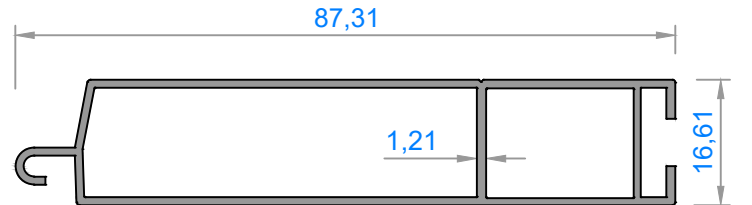

1503 - 0,642 kg/m

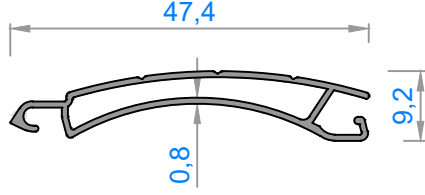

3097 - 0,232 kg/m

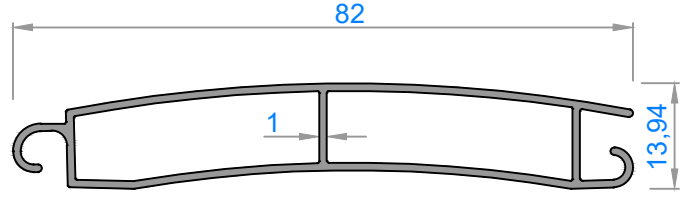

3254 - 0,532 kg/m

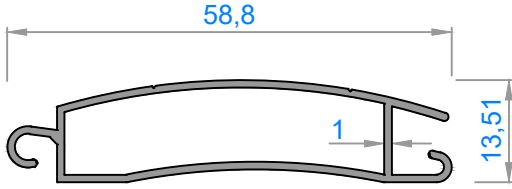

1504 - 0,378 kg/m

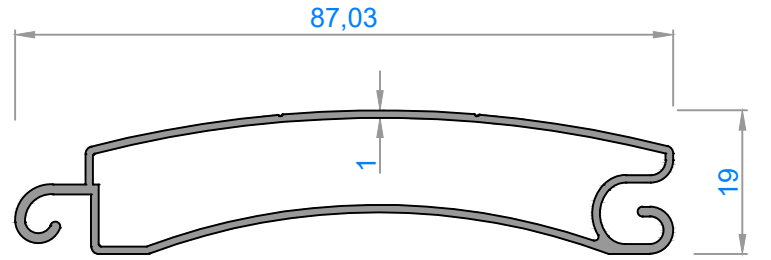

1505 - 0,607 kg/m

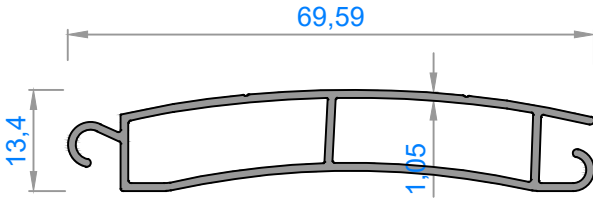

2455 - 0,480 kg/m

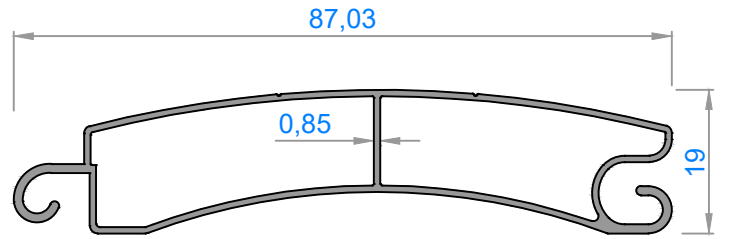

1507 - 0,555 kg/m

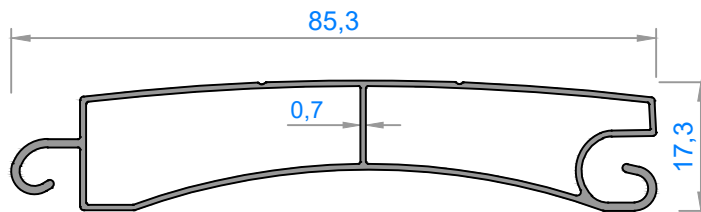

4227 - 0,484 kg/m

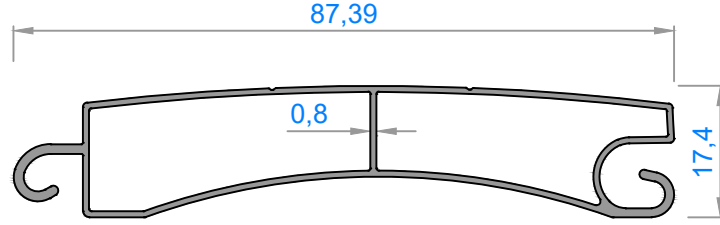

2387 - 0,533 kg/m

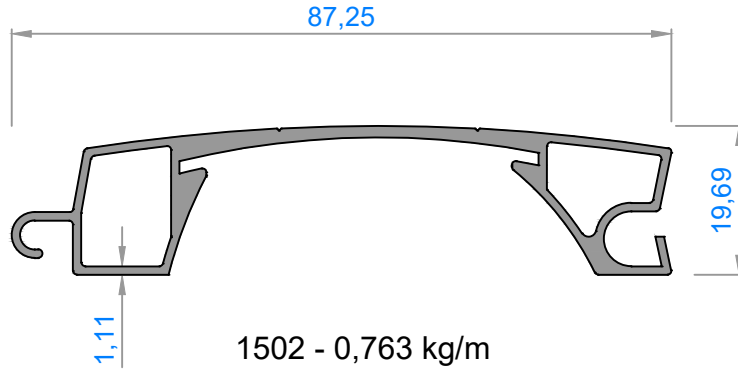

1502 - 0,763 kg/m

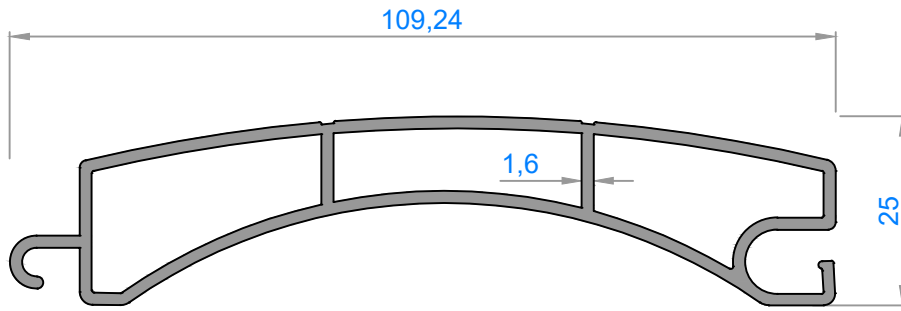

3623 - 1,225 kg/m

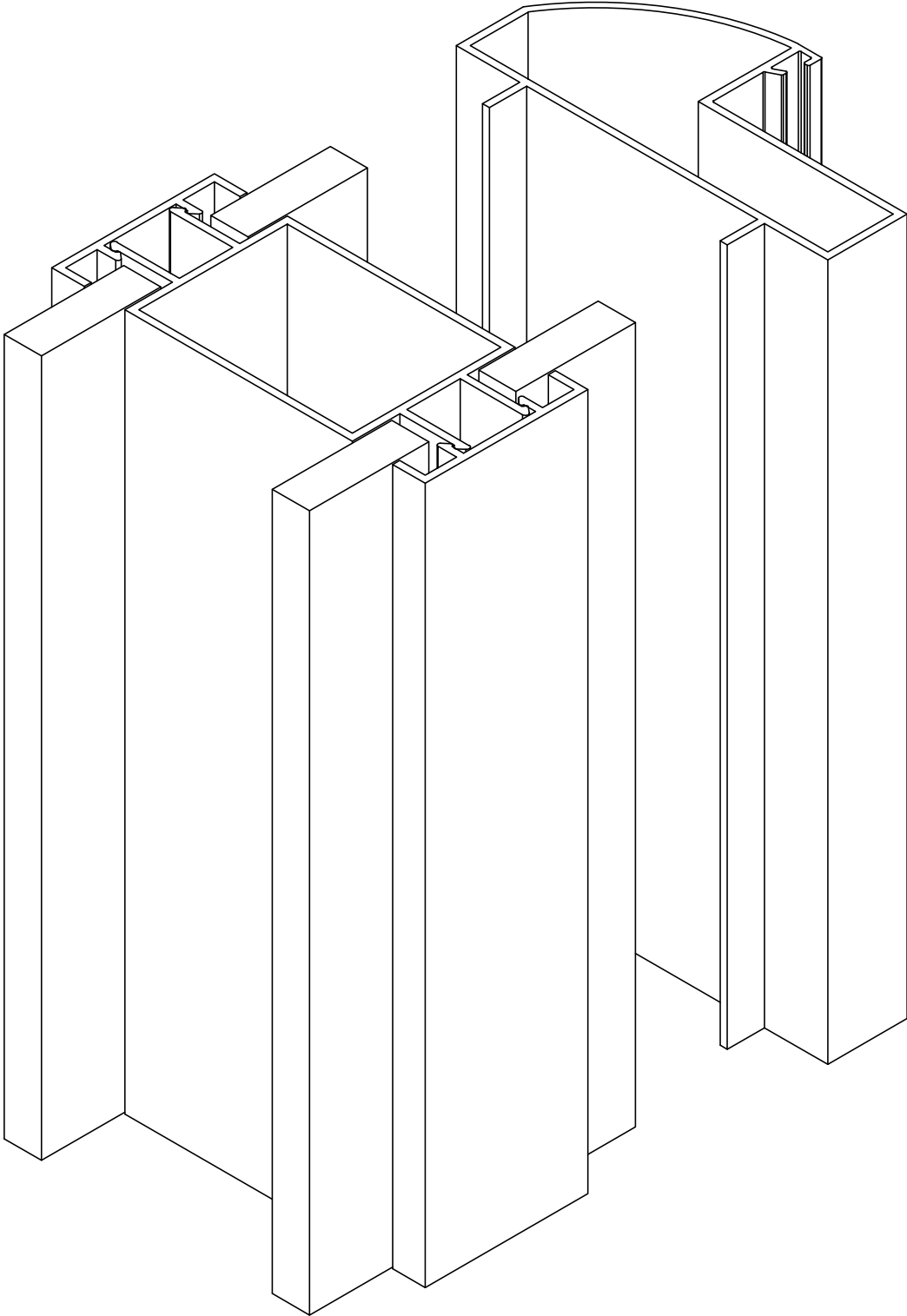

OFİS BÖLME PROFİLLERİ / Office Partitions Profiles

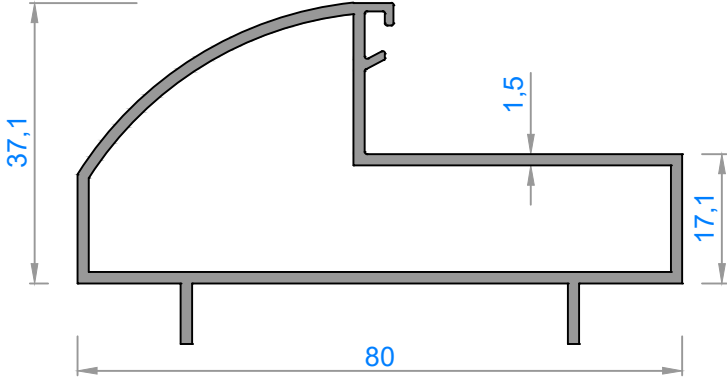

2638 - 0,962 kg/m

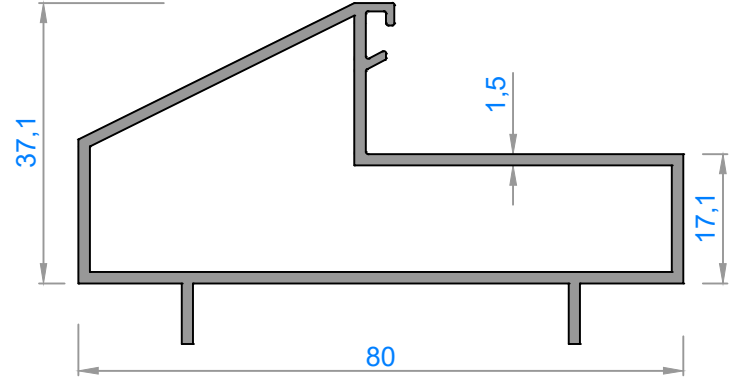

2640 - 0,965 kg/m

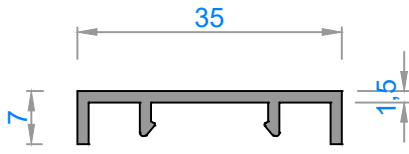

1643 - 0,225 kg/m

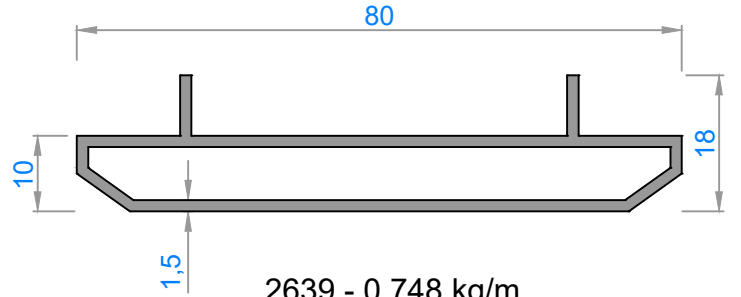

2639 - 0,748 kg/m

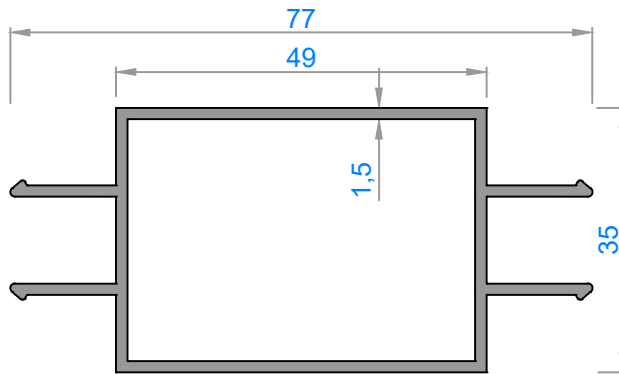

1381 - 0,890 kg/m

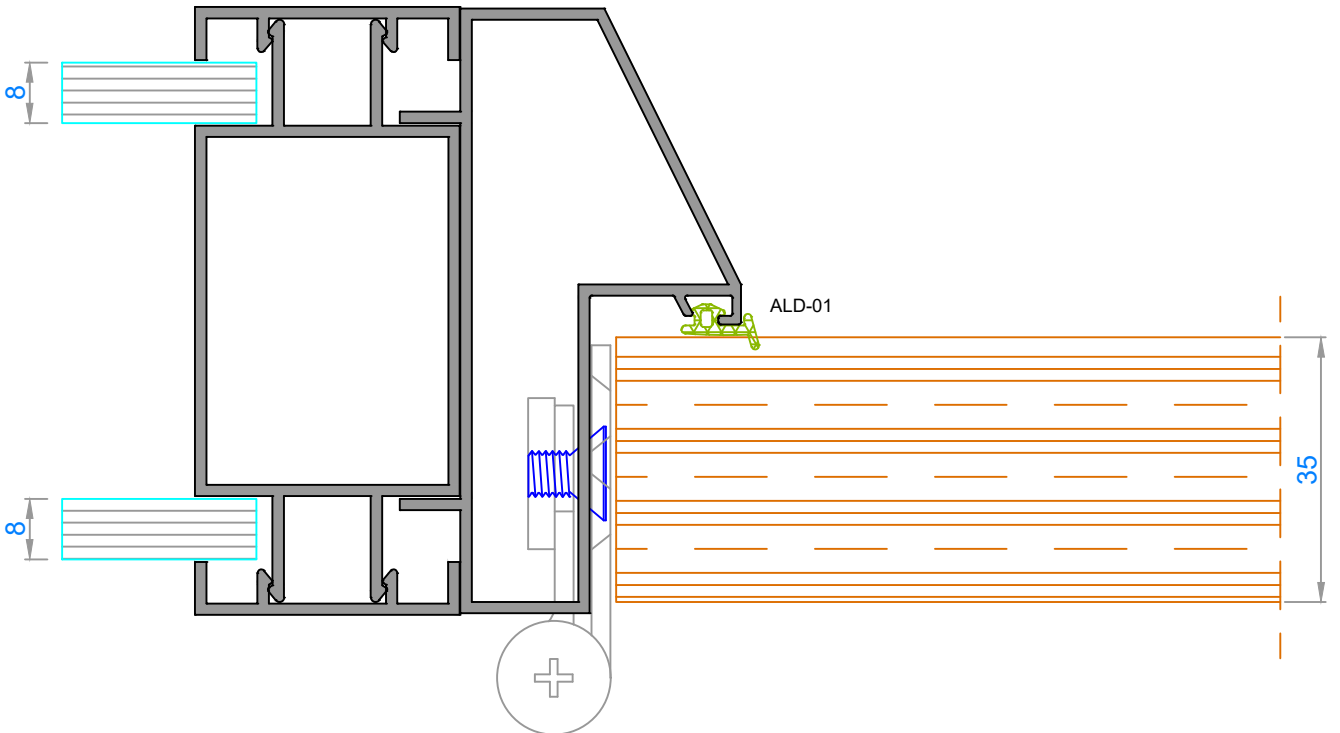
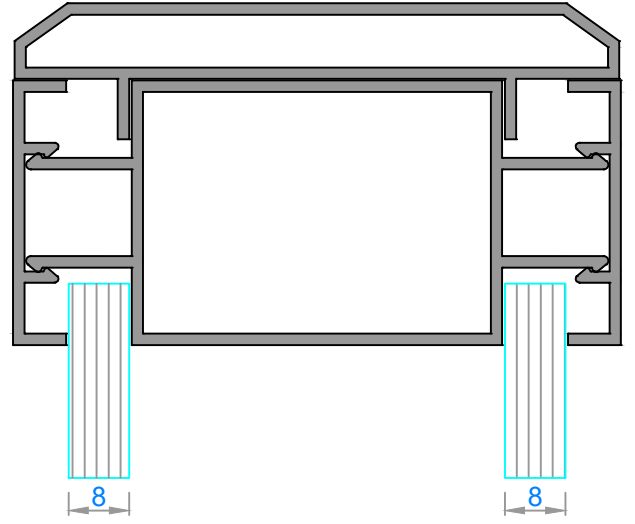
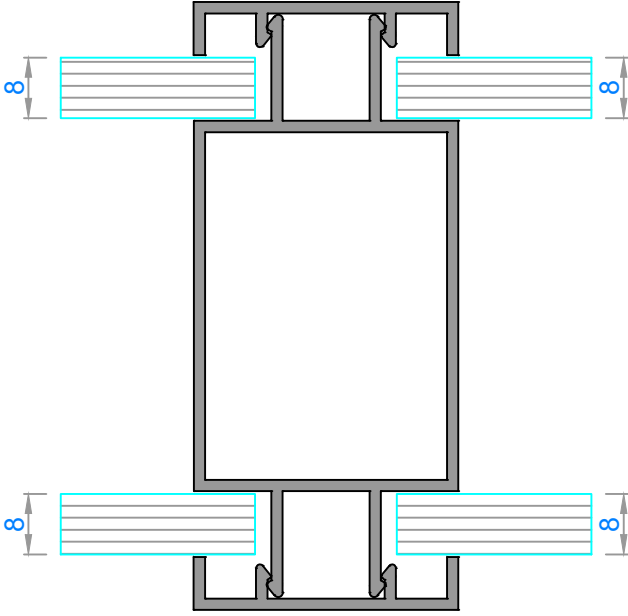

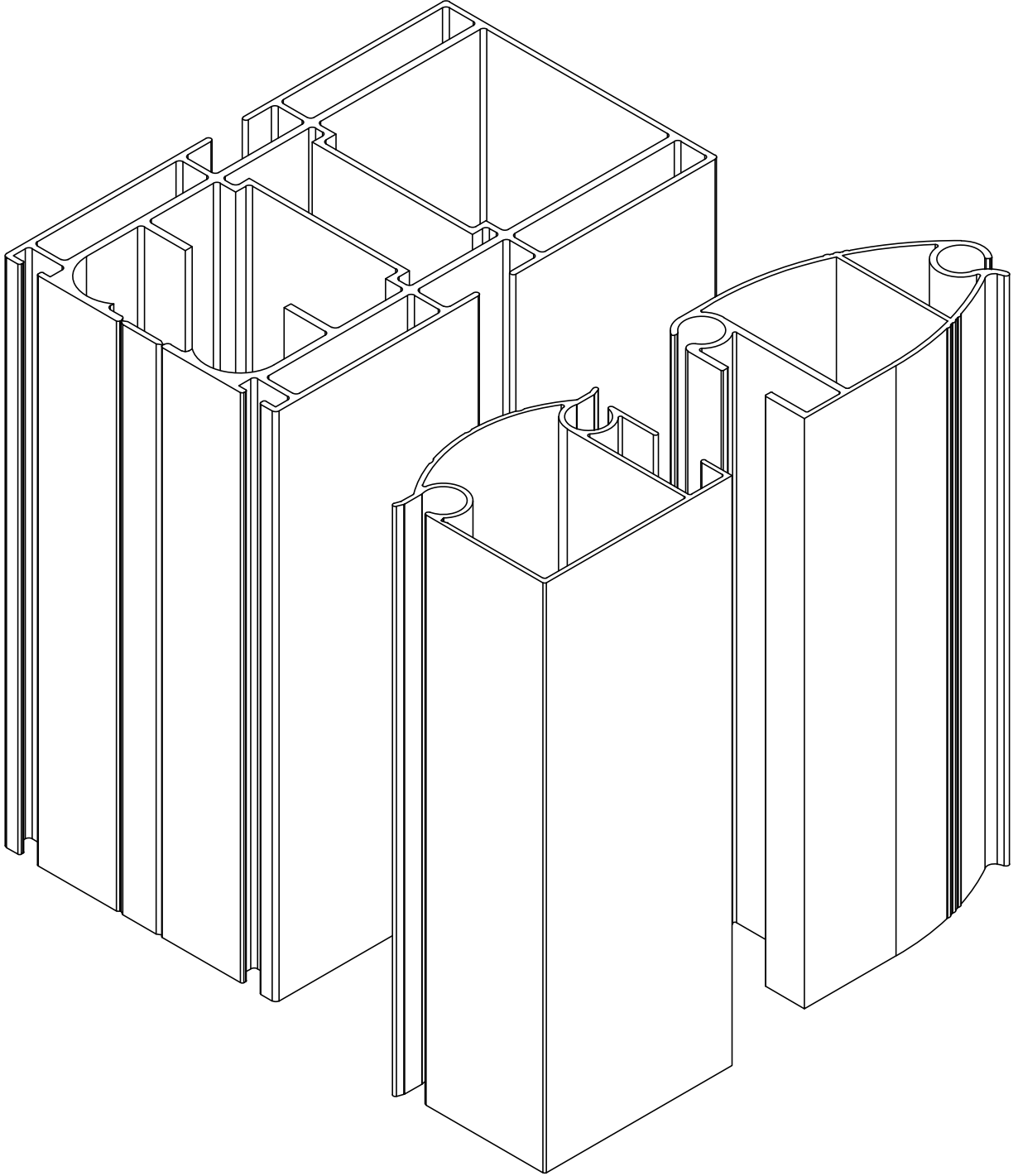

TENTE PROFİLLERİ / Awning Profiles

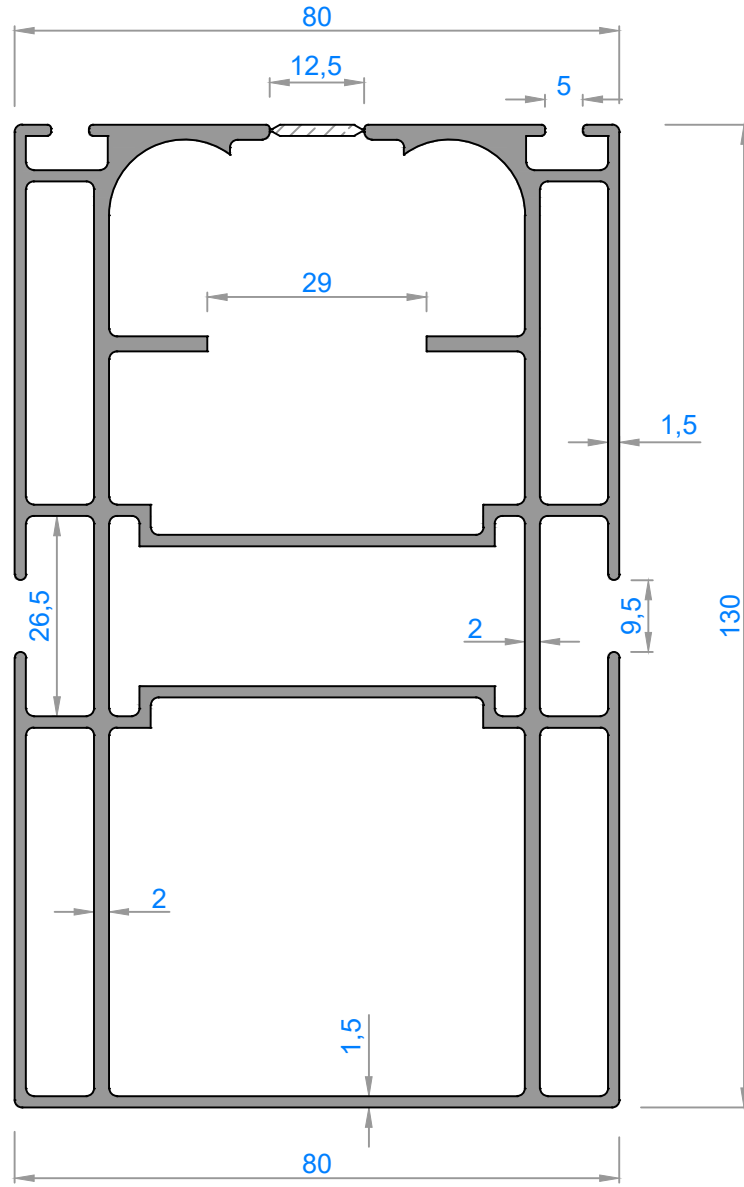

4768 - 3,982 kg/m

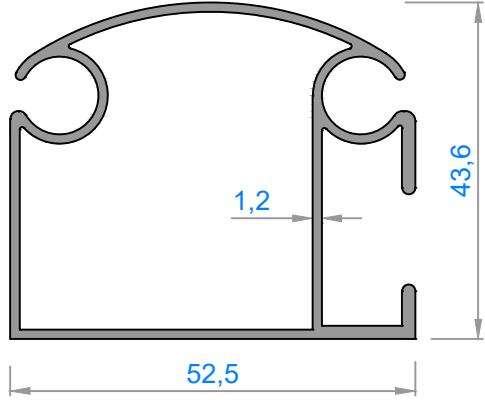

1190 - 0,791 kg/m

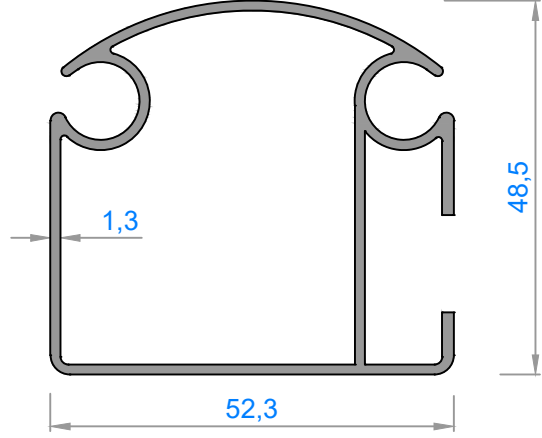

1230 - 0,853 kg/m

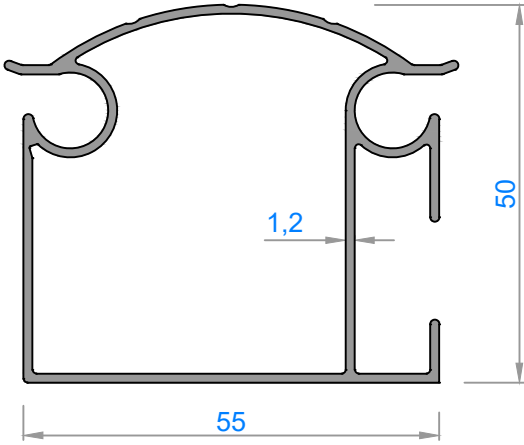

1233 - 0,834 kg/m

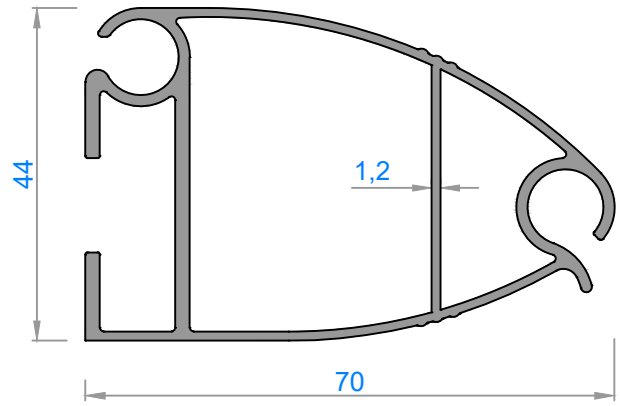

1717 - 1,087 kg/m

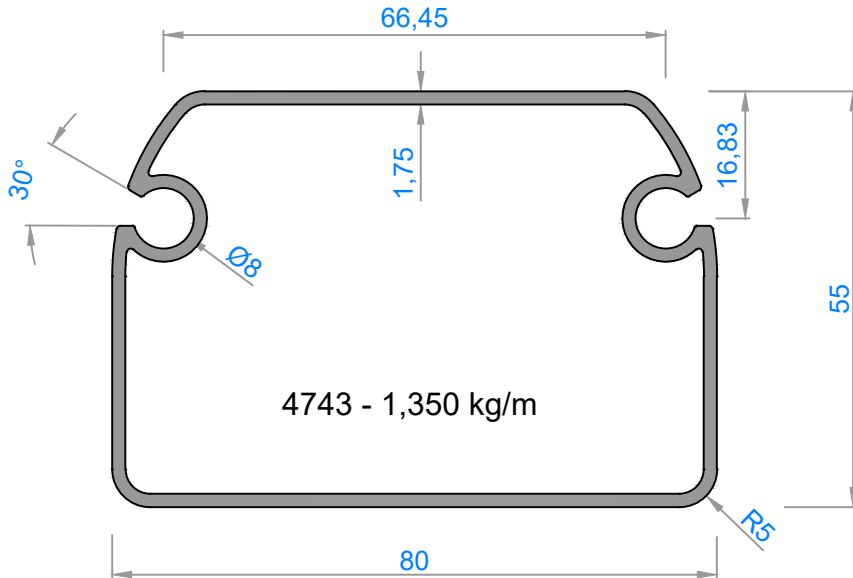

4743 - 1,350 kg/m

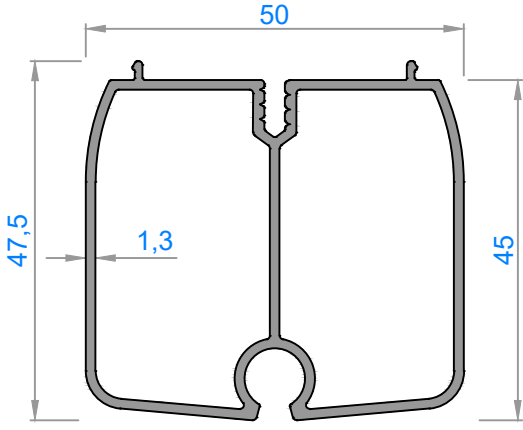

4742 - 0,840 kg/m

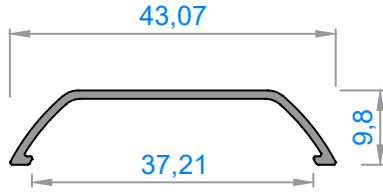

4741 - 0,160 kg/m

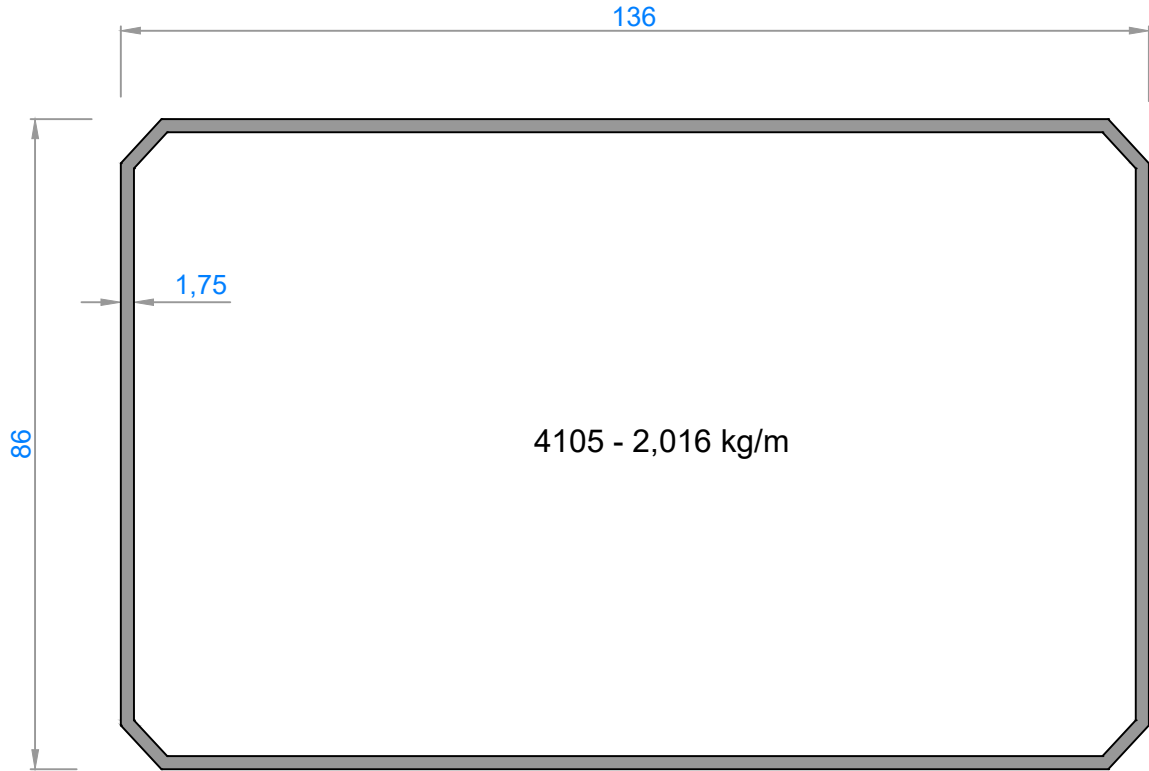
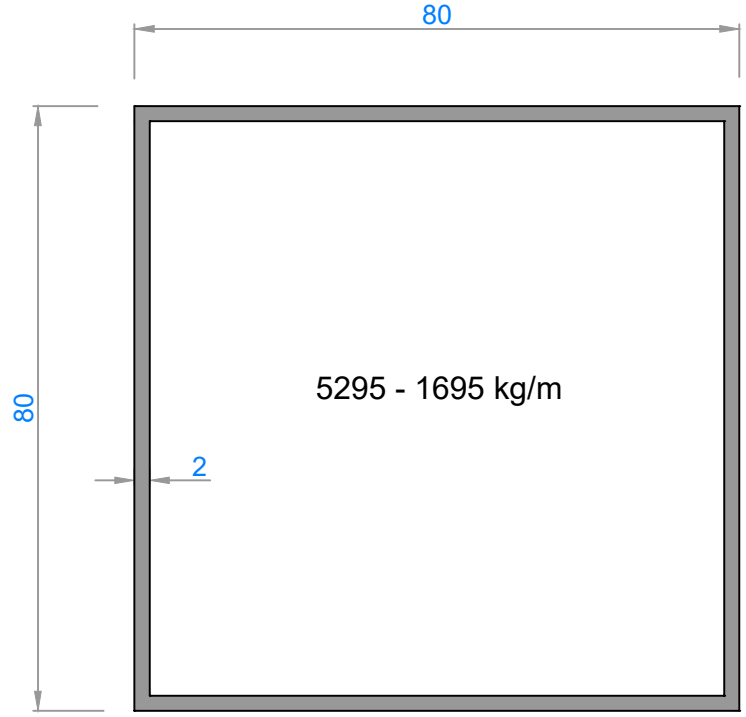

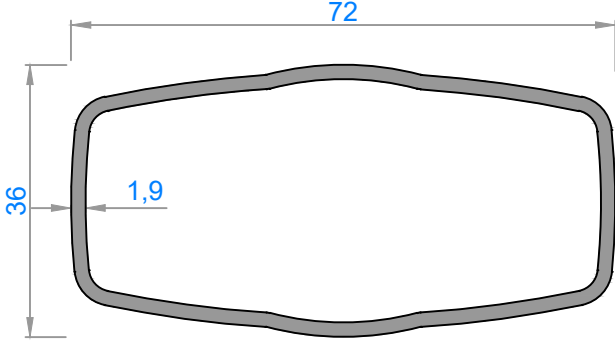

3371 - 0,949 kg/m

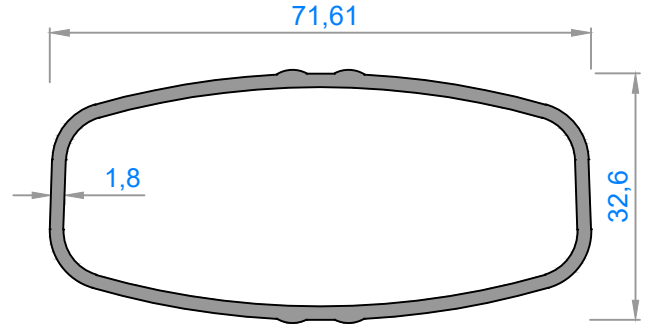

1511 - 0,865 kg/m

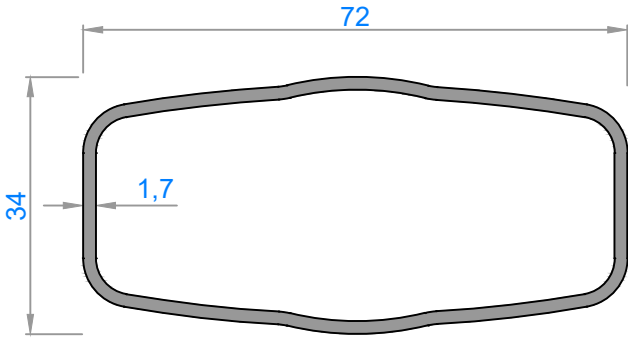

2101 - 0,840 kg/m

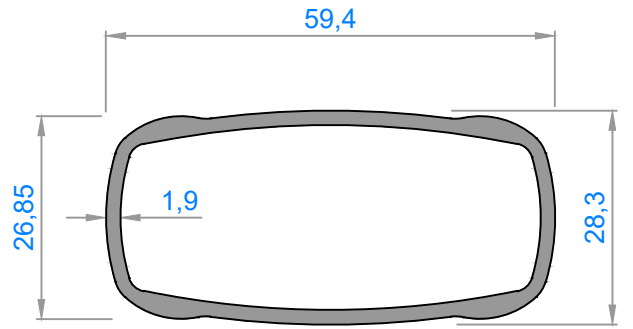

1885 - 0,840 kg/m

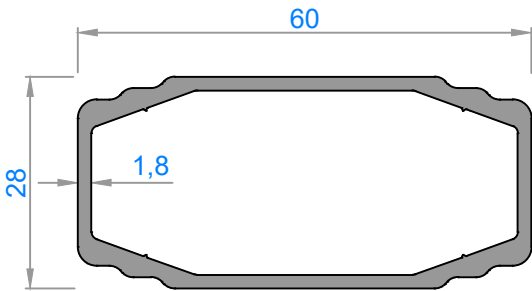

1360 - 0,904 kg/m

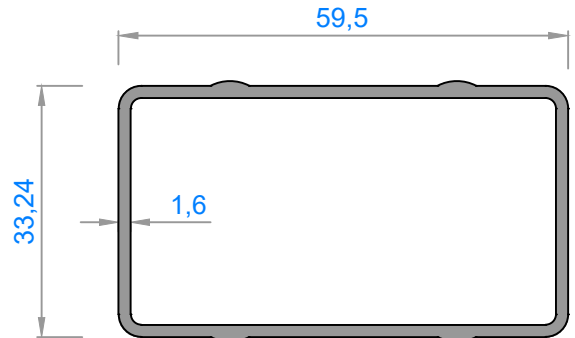

1189 - 0,795 kg/m

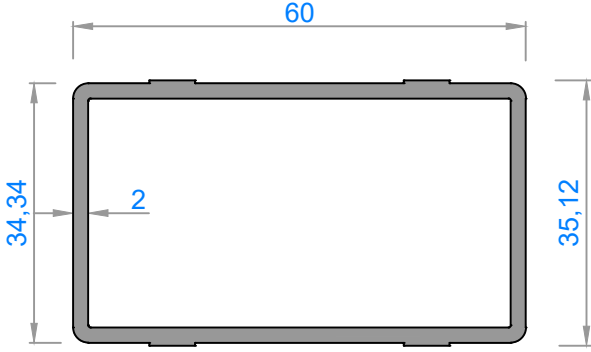

1183 - 1,000 kg/m

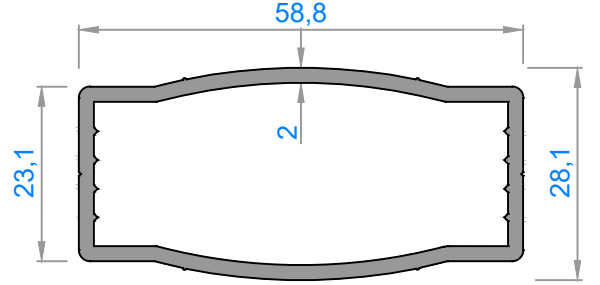

1195 - 0,855 kg/m

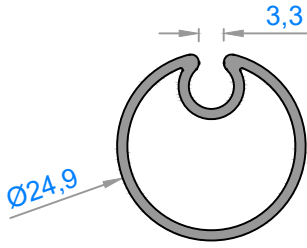

1734 - 0,323 kg/m

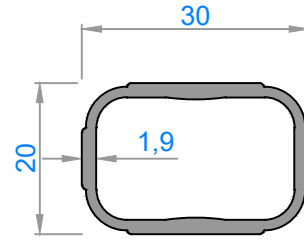

1364 - 0,390 kg/m

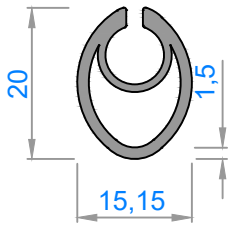

1192 - 0,263 kg/m

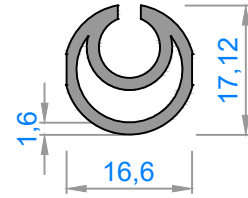

1191 - 0,239 kg/m

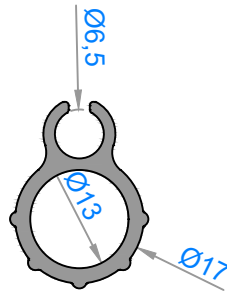

5126 - 0,340 kg/m

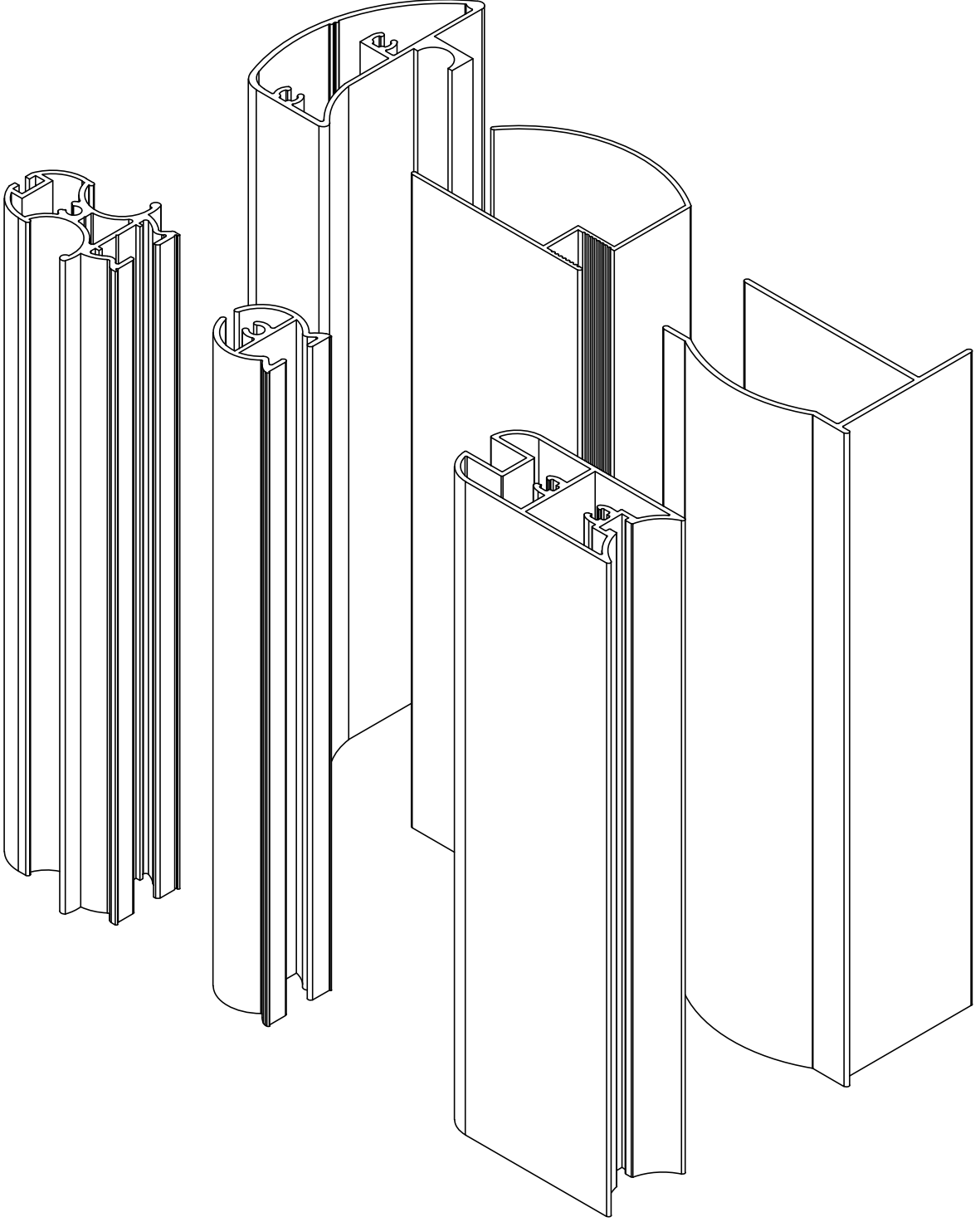

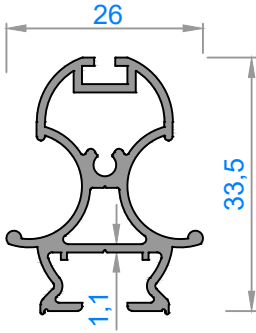

1288 - 0,455 kg/m
STOK BOYU :
540 cm

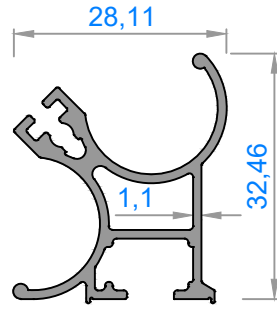

1282 - 0,436 kg/m
STOK BOYU :
540 cm

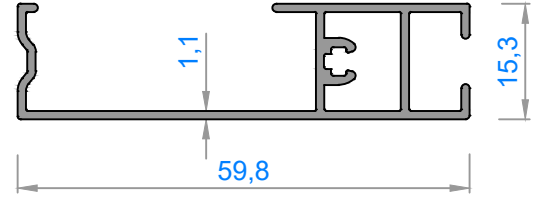

1221 - 0,437 kg/m
STOK BOYU :
600 cm

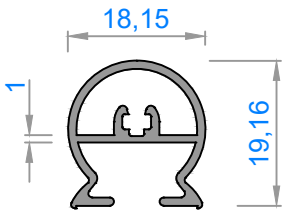

1283 - 0,249 kg/m
STOK BOYU :
520 cm

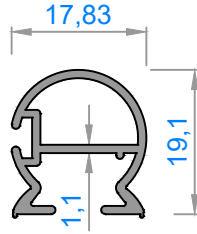

1284 - 0,242 kg/m
STOK BOYU :
540 cm

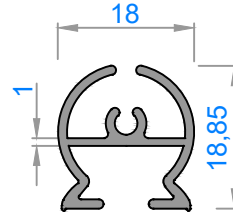

1225 - 0,255 kg/m
STOK BOYU :
540 cm

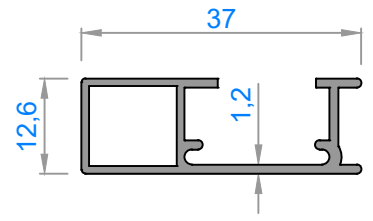

1376 - 0,293 kg/m
STOK BOYU :
600 cm

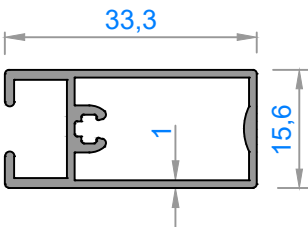

1290 - 0,331 kg/m
STOK BOYU :
600 cm

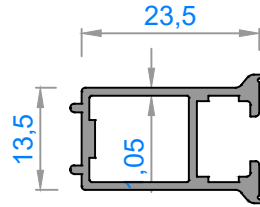

1286 - 0,269 kg/m
STOK BOYU :
550 cm

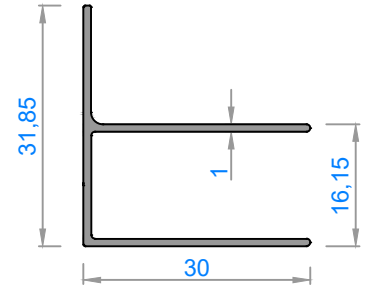

1289 - 0,246 kg/m
STOK BOYU :
550 cm

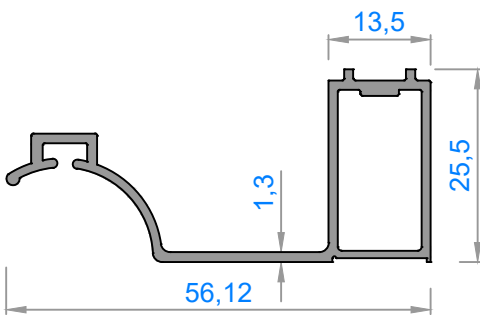

1285 - 0,455 kg/m
STOK BOYU :
550 cm

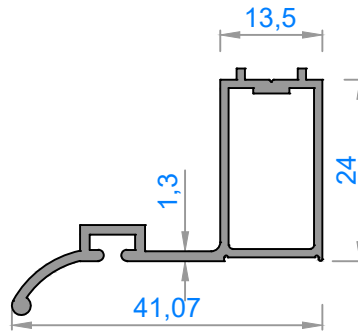

1281 - 0,380 kg/m
STOK BOYU :
550 cm

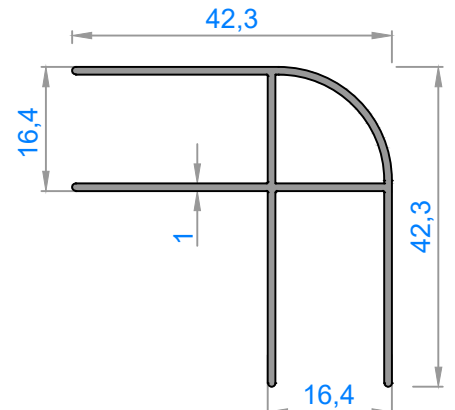

1226 - 0,431 kg/m
STOK BOYU :
550 cm

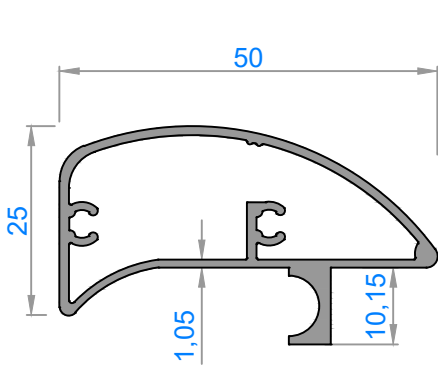

1879 - 0,569 kg/m

STOK BOYU :
600 cm (TERMİKSİZ)

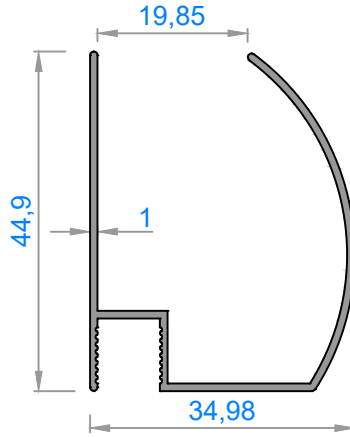

2904 - 0,352 kg/m

STOK BOYU :
550 cm - 610 cm

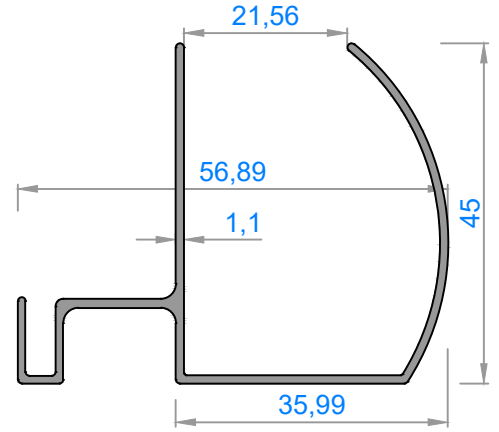

3587 - 0,493 kg/m

STOK BOYU :
550 cm

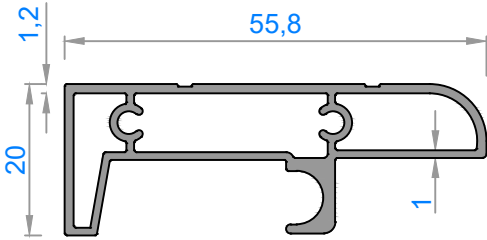

3451 - 0,577 kg/m

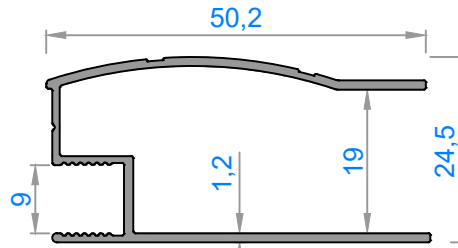

3450 - 0,403 kg/m

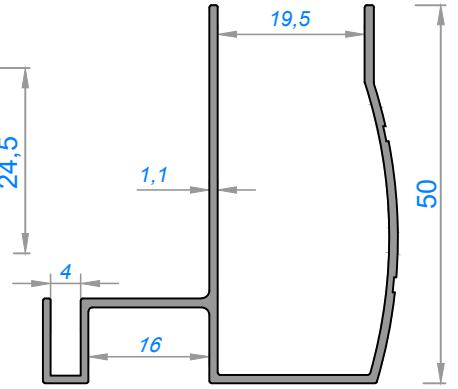

4178 - 0,494 kg/m

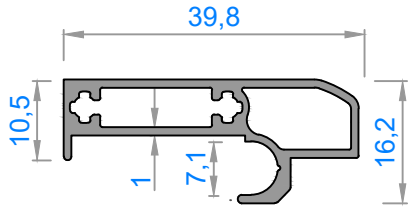

3123 - 0,368 kg/m

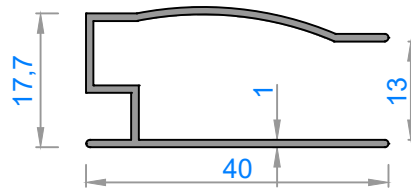

3126 - 0,276 kg/m

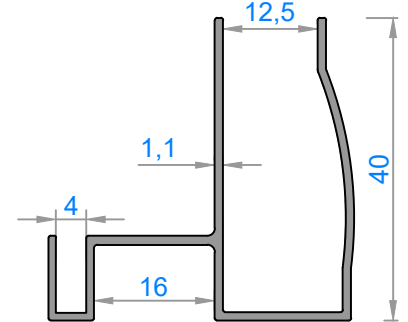

4267 - 0,411 kg/m

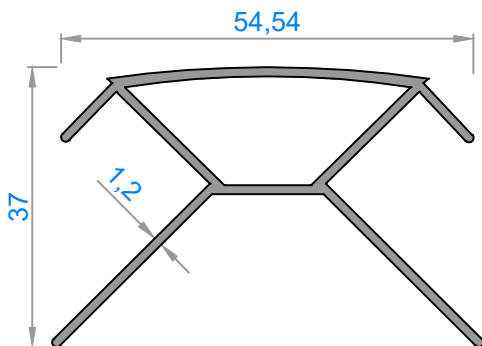

2531 - 0,570 kg/m

STOK BOYU :
550 cm

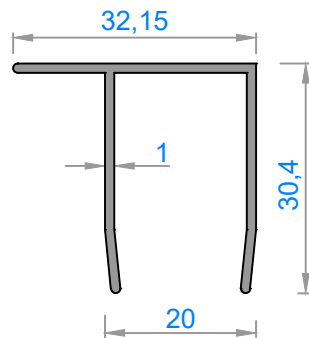

1958 - 0,248 kg/m

STOK BOYU :
550 cm - 610 cm

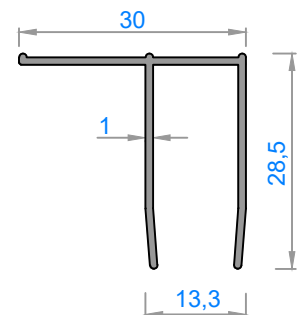

4818 - 0,230 kg/m

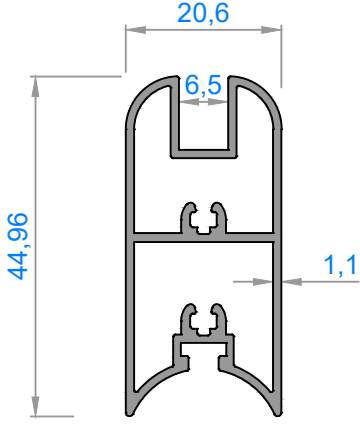

3390 - 0,579 kg/m

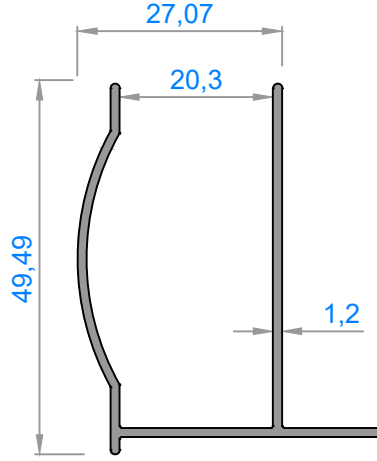

3391 - 0,423 kg/m

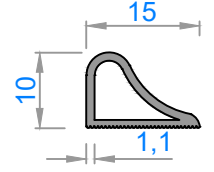

3586 - 0,113 kg/m

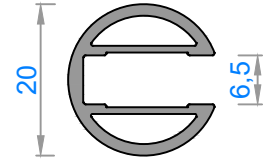

3392 - 0,295 kg/m

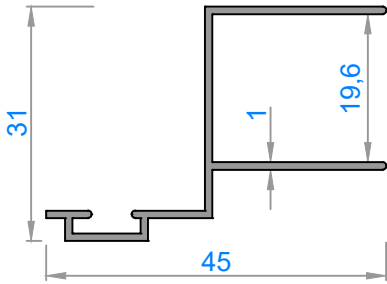

1492 - 0,285 kg/m

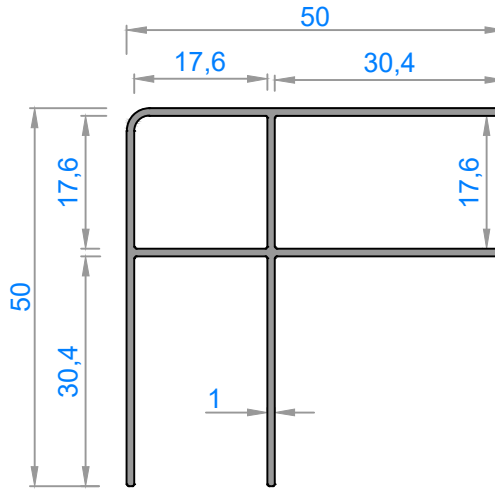

3636 - 0,528 kg/m

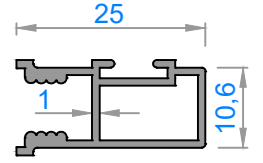

1494 - 0,237 kg/m

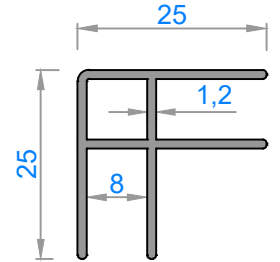

3637 - 0,307 kg/m

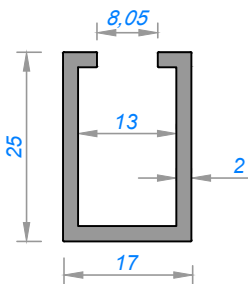

4169 - 0,368 kg/m

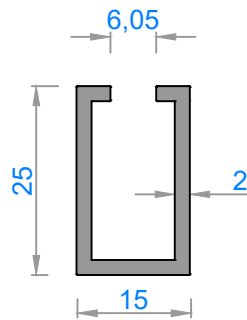

4125 - 0,357 kg/m

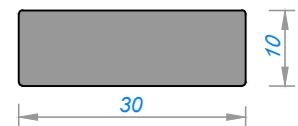

3967 - 0,813 kg/m

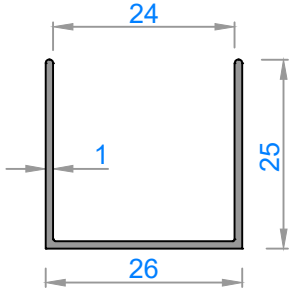

1695 - 0,201 kg/m

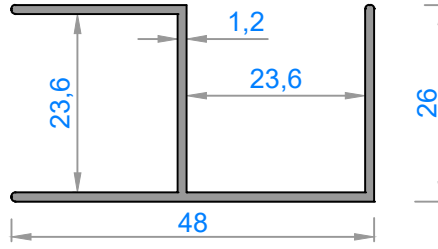

1236 - 0,391 kg/m

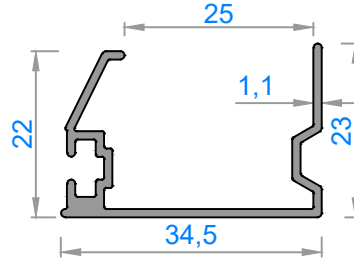

1237 - 0,298 kg/m

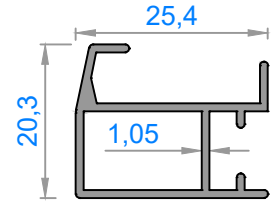

1238 - 0,274 kg/m

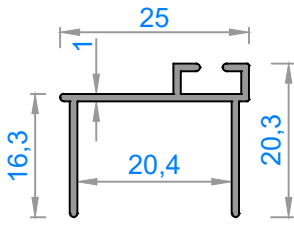

1206 - 0,187 kg/m

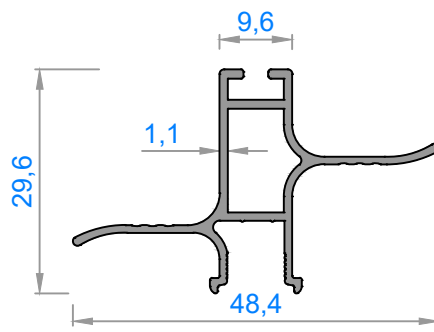

1731 - 0,347 kg/m

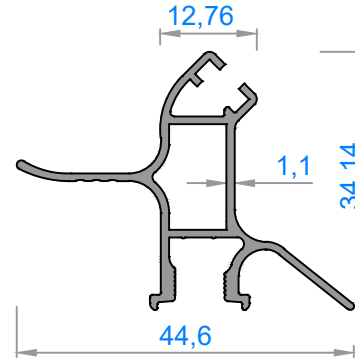

1732 - 0,383 kg/m

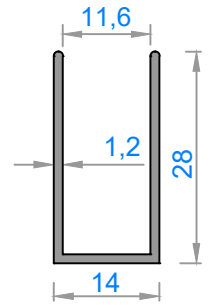

1234 - 0,220 kg/m

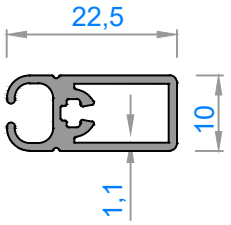

1730 - 0,231 kg/m

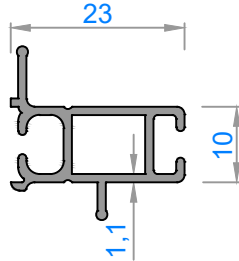

1244 - 0,258 kg/m

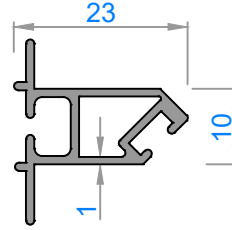

1242 - 0,250 kg/m

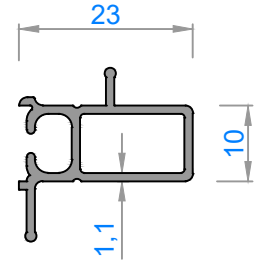

1176 - 0,247 kg/m

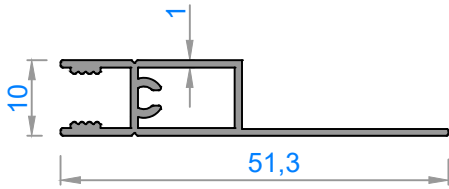

1472 - 0,286 kg/m

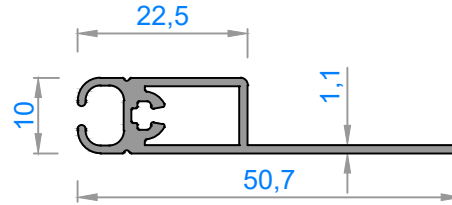

1246 - 0,304 kg/m

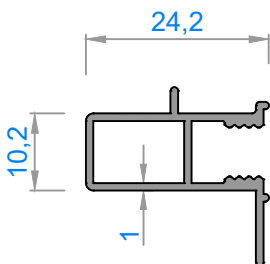

1473 - 0,236 kg/m

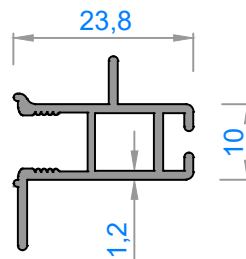

1697 - 0,270 kg/m

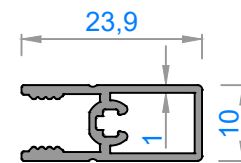

1729 - 0,220 kg/m

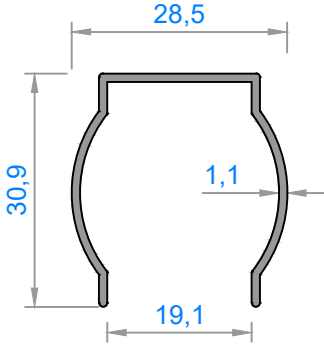

4394 - 0,250 kg/m

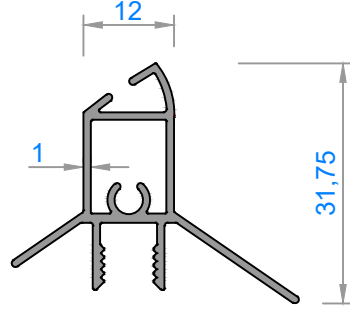

4397 - 0,338 kg/m

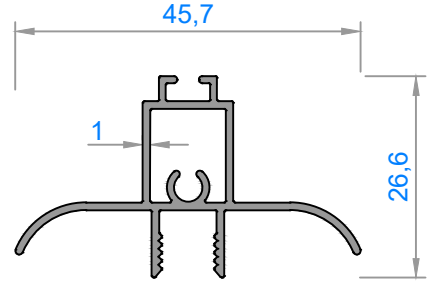

4398 - 0,334 kg/m

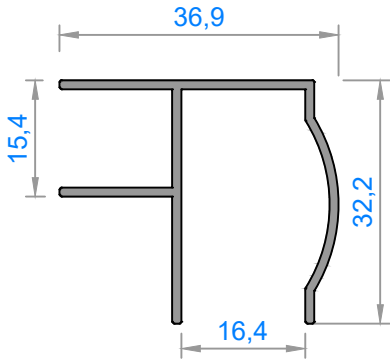

4401 - 0,363 kg/m

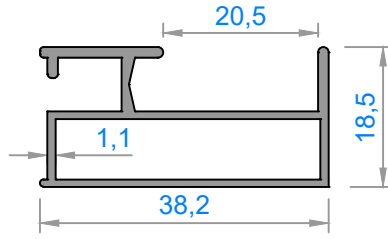

4396 - 0,381 kg/m

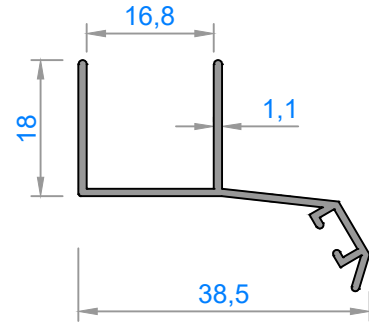

4403 - 0,250 kg/m

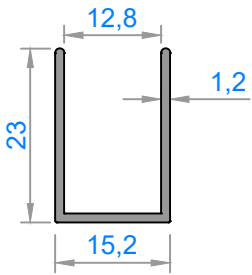

4399 - 0,190 kg/m

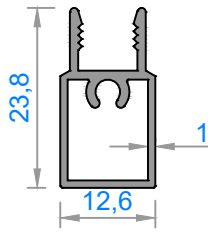

4395 - 0,228 kg/m

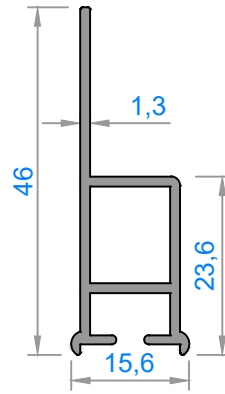

4402 - 0,347 kg/m

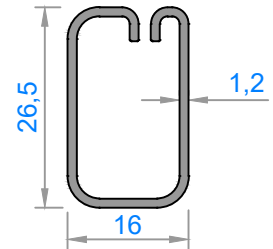

4400 - 0,255 kg/m

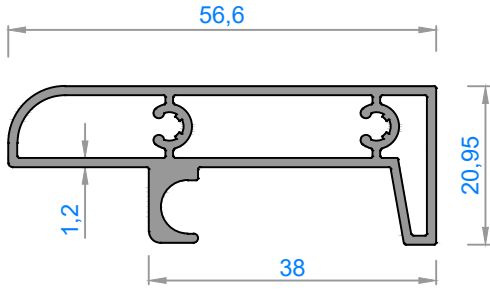

4797 - 0,661 kg/m

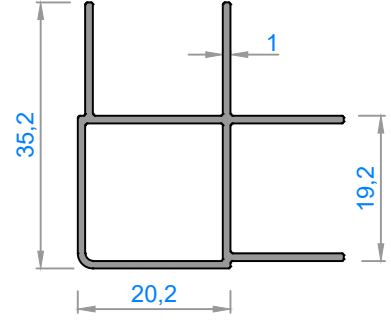

4798 - 0,369 kg/m

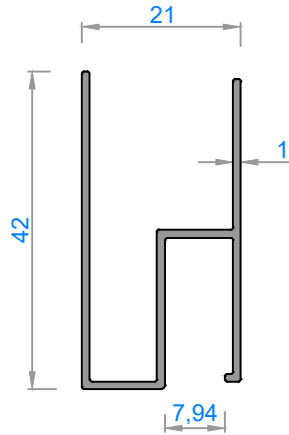

4796 - 0,339 kg/m

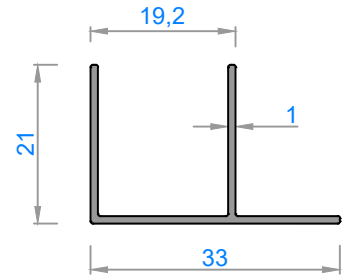

4795 - 0,197 kg/m

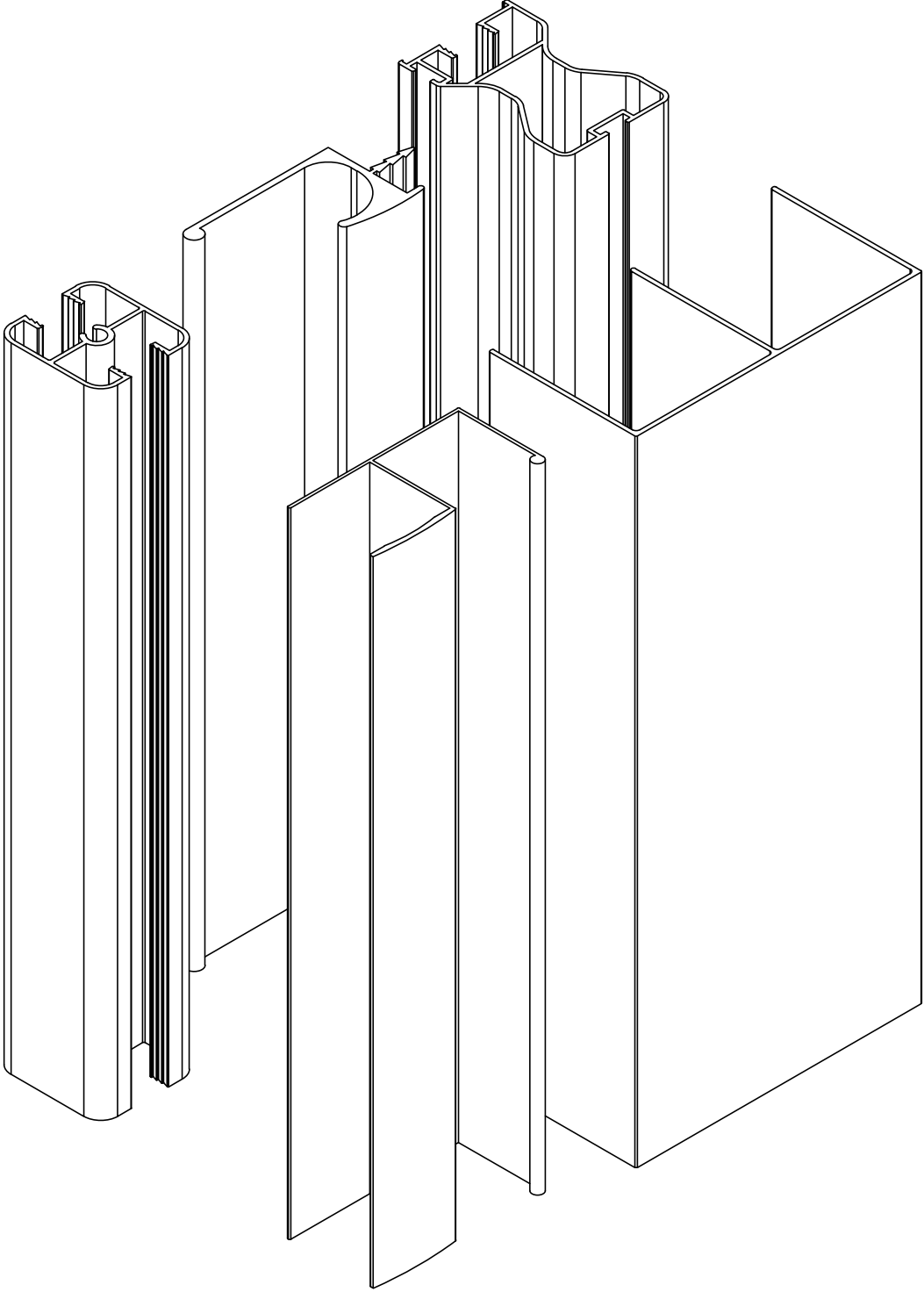

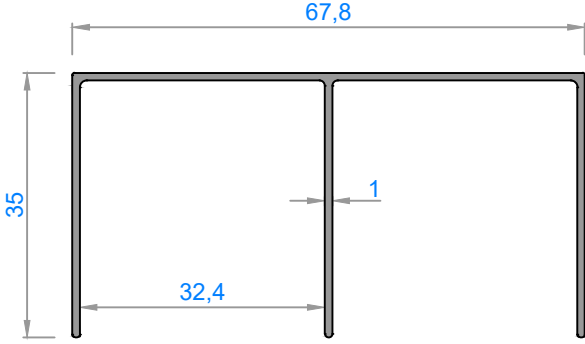

4051 - 0,460 kg/m

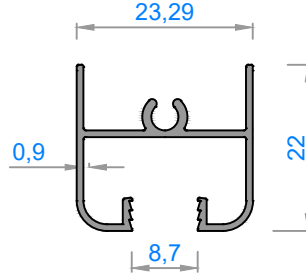

4049 - 0,231 kg/m

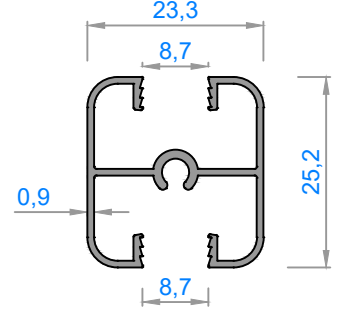

4050 - 0,285 kg/m

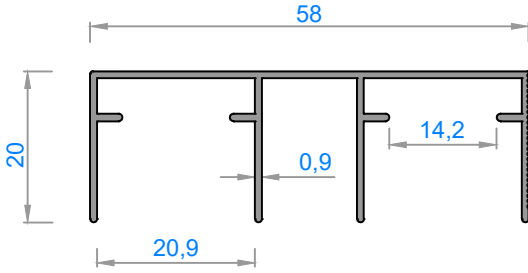

4444 - 0,357 kg/m

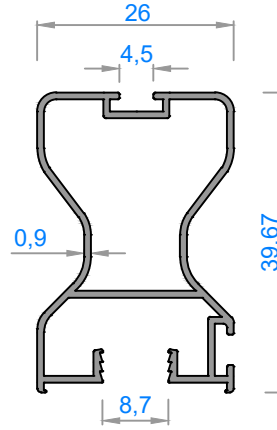

4053 - 0,395 kg/m

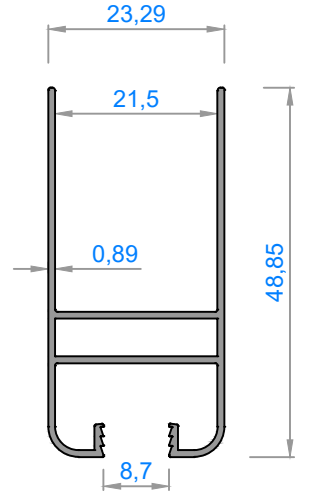

4048 - 0,384 kg/m

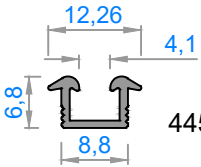

4451 - 0,073 kg/m

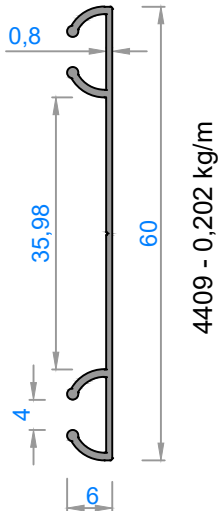

4409 - 0,202 kg/m

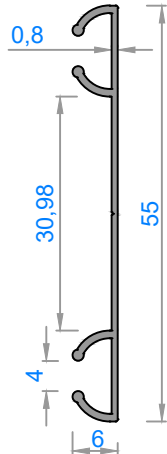

4408 - 0,191 kg/m

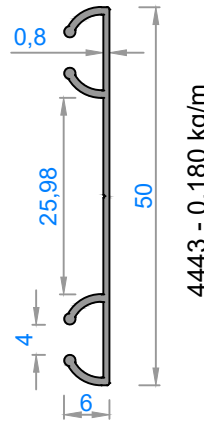

4443 - 0,180 kg/m

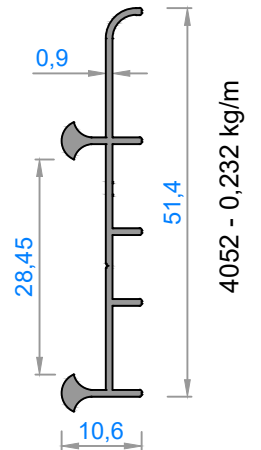

4052 - 0,232 kg/m

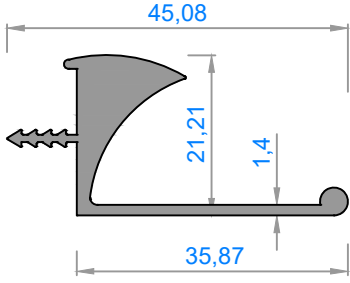

2207 - 0,526 kg/m

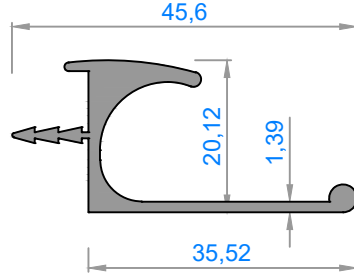

2508 - 0,428 kg/m

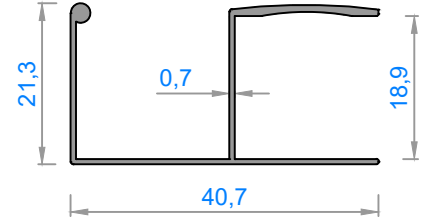

4427 - 0,219 kg/m

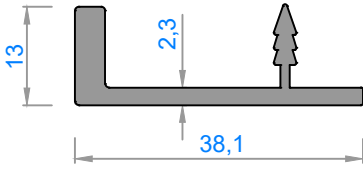

3326 - 0,409 kg/m

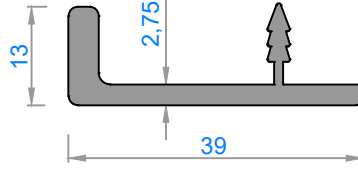

4613 - 0,455 kg/m

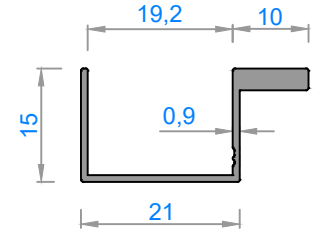

4405 - 0,190 kg/m

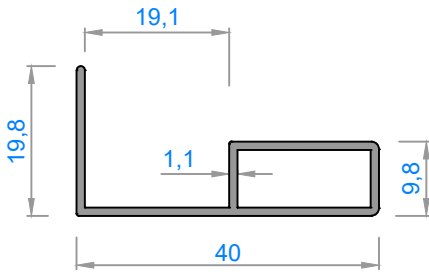

4406 - 0,278 kg/m

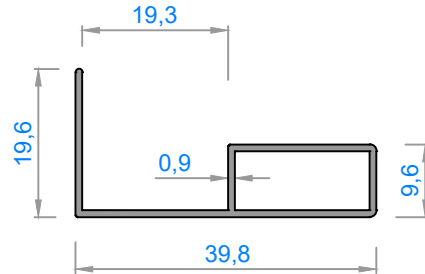

4450 - 0,228 kg/m

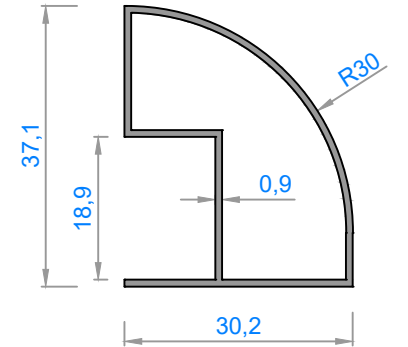

4435 - 0,318 kg/m

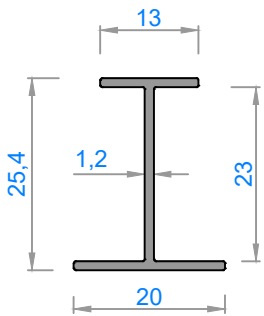

4745 - 0,182 kg/m

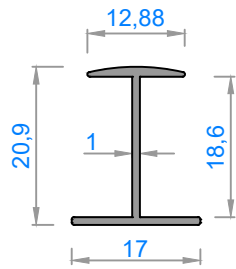

4428 - 0,133 kg/m

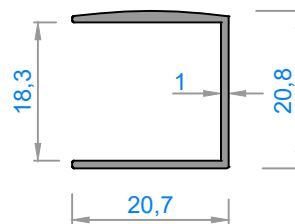

4429 - 0,176 kg/m

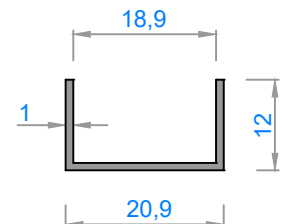

4407 - 0,116 kg/m

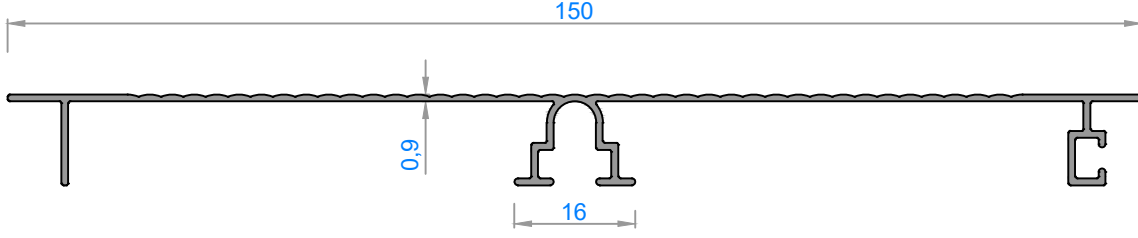

3069 - 0,501 kg/m

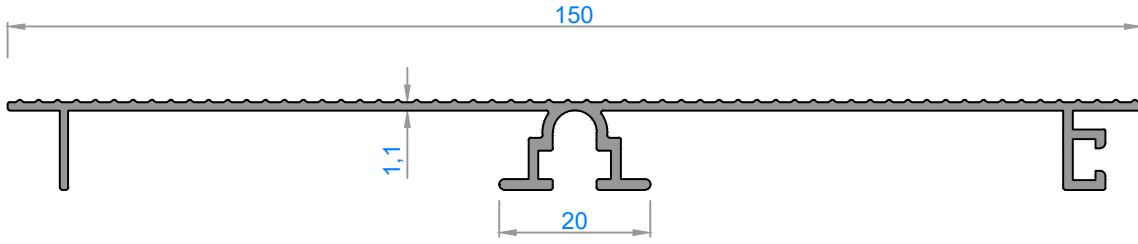

2572 - 0,727 kg/m

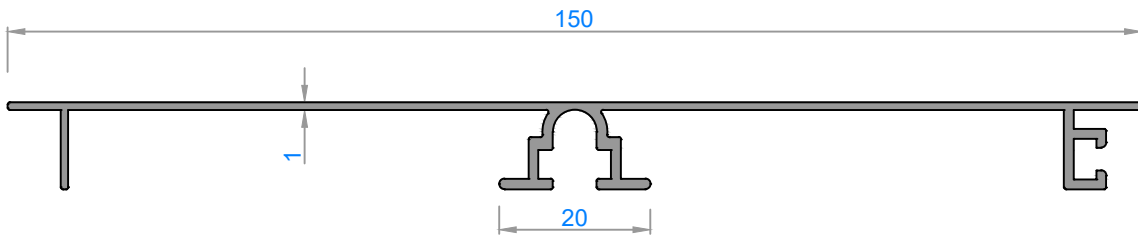

2718 - 0,651 kg/m

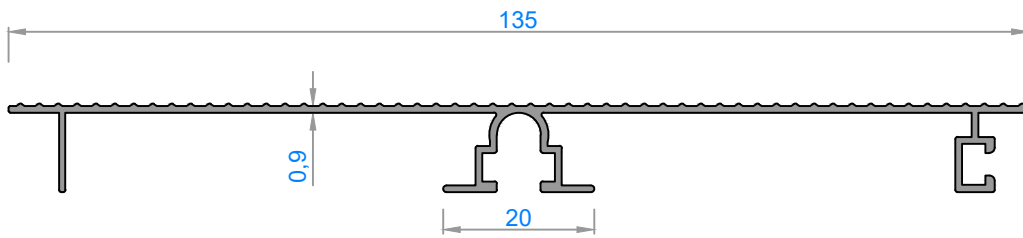

4747 - 0,535 kg/m

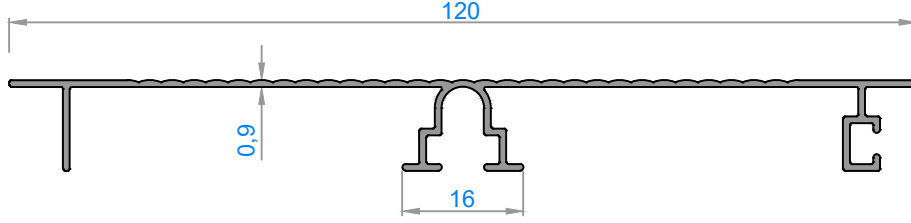

3070 - 0,436 kg/m

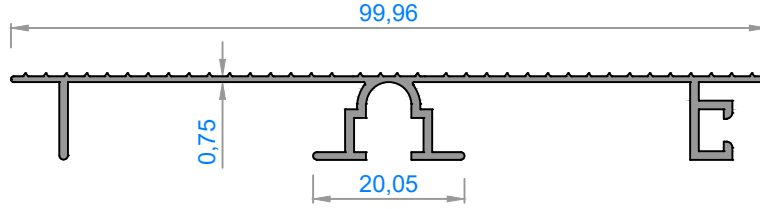

2534 - 0,429 kg/m

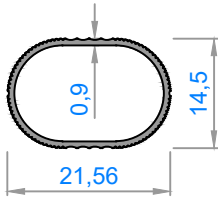

4411 - 0,126 kg/m

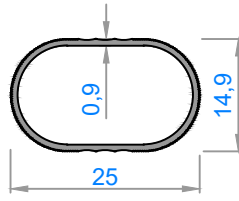

4410 - 0,145 kg/m

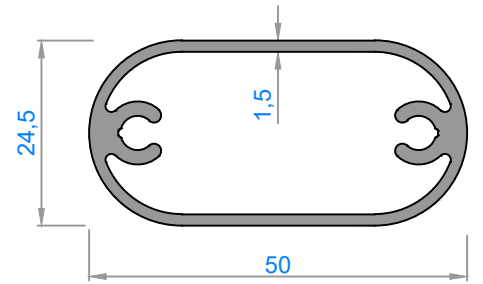

3849 - 0,699 kg/m

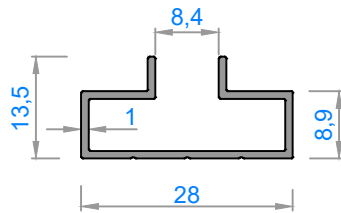

4551 - 0,190 kg/m

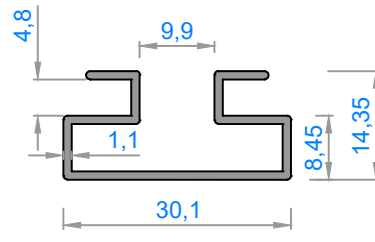

1947 - 0,257 kg/m

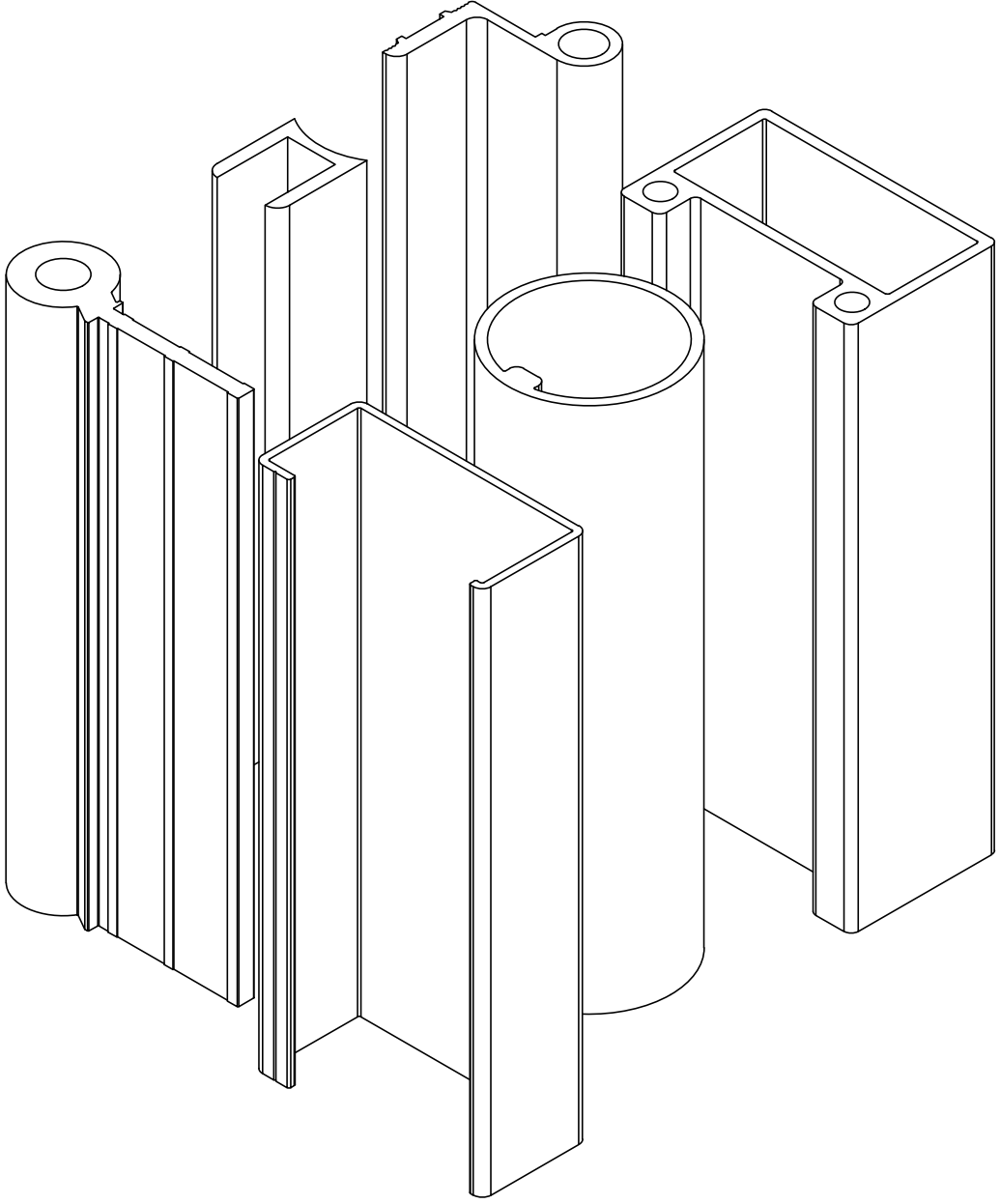

KAPI & PENCERE AKSESUAR PROFİLLERİ / Doors Windows Accessory Profiles

KÜPEŞTE AKSESUARLARI PROFİLLERİ / Handrail Accessory Profiles

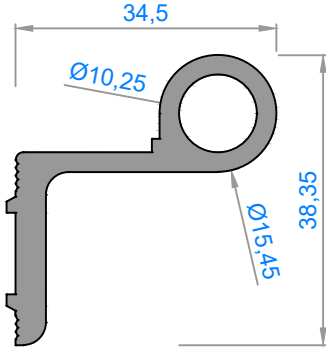

4532 - 0,714 kg/m

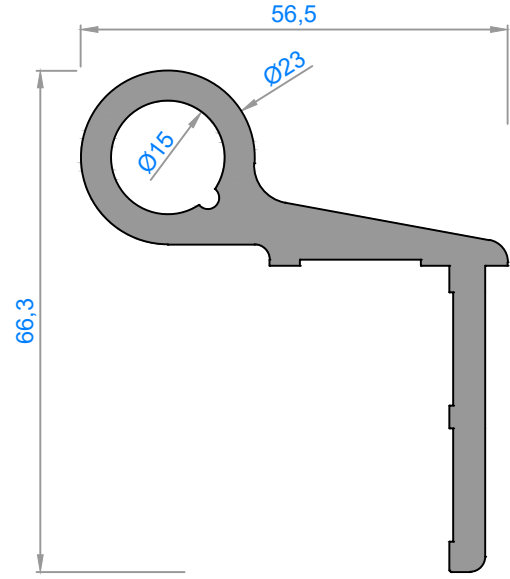

4531 - 1,690 kg/m

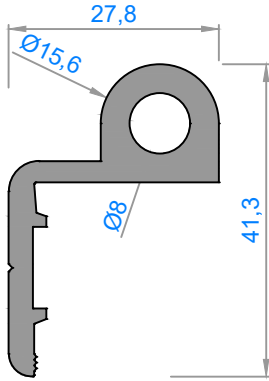

4533 - 0,778 kg/m

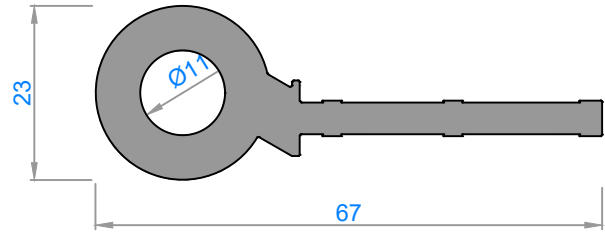

4530 - 1,435 kg/m

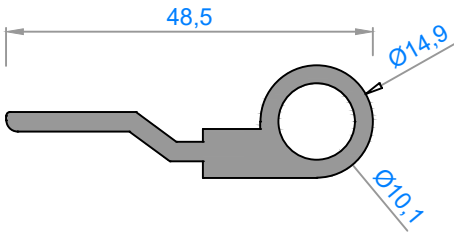

4534- 0,612 kg/m

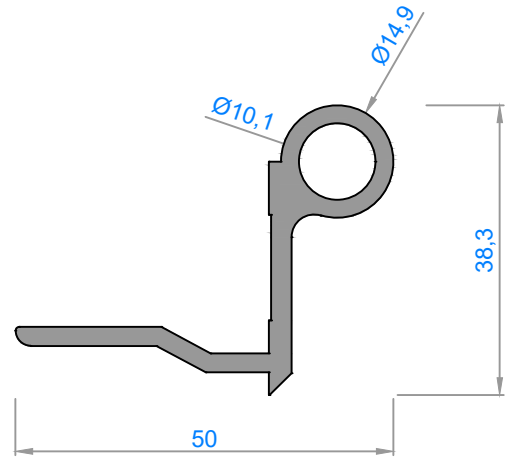

4535- 0,718 kg/m

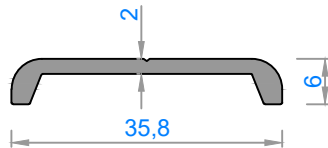

4536- 0,245 kg/m

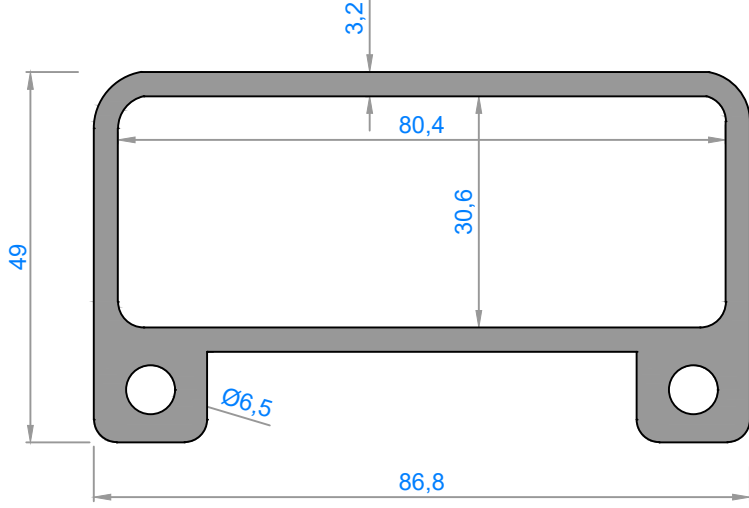

3817 - 2,789 kg/m

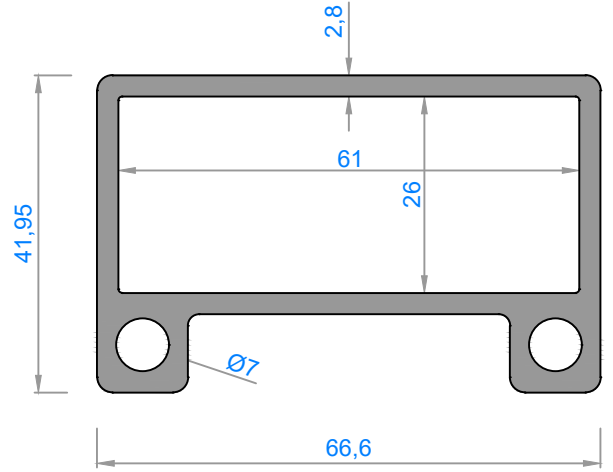

3968 - 1,884 kg/m

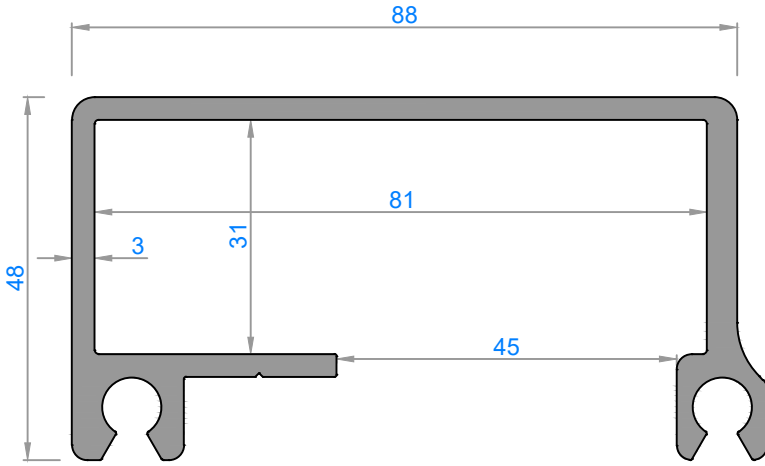

4296 - 2,077 kg/m

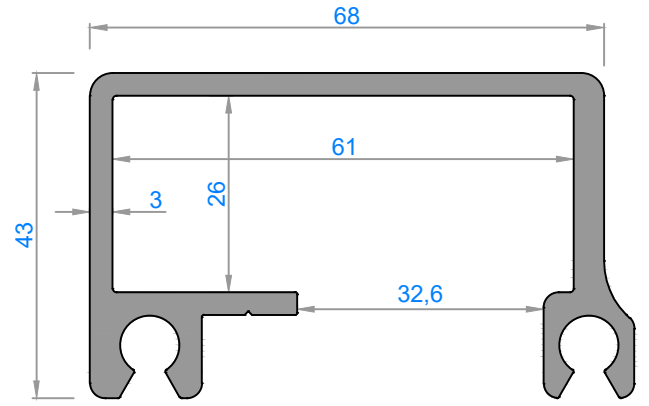

4295 - 1,758 kg/m

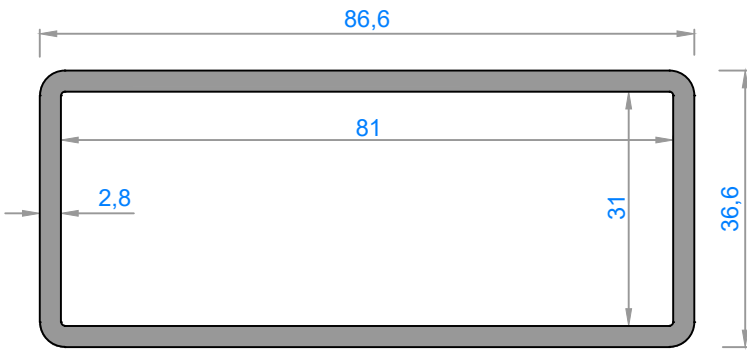

4482- 1,760 kg/m

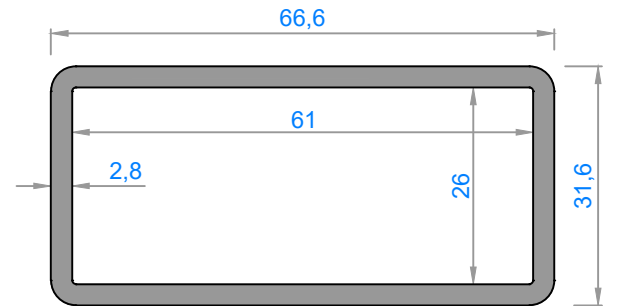

4481- 1,380 kg/m

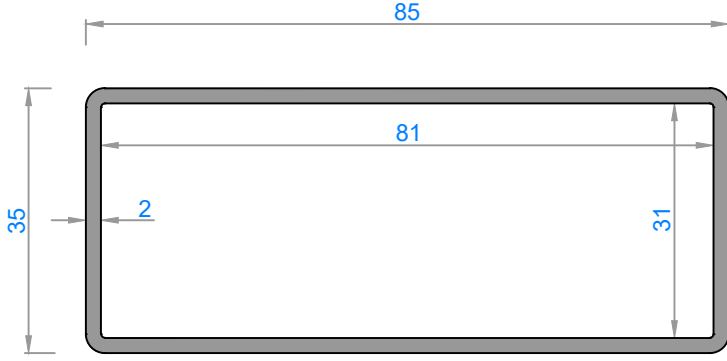

4383 - 1,243 kg/m

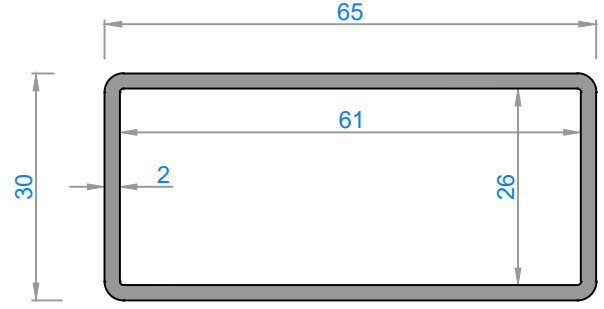

4342 - 0,972 kg/m

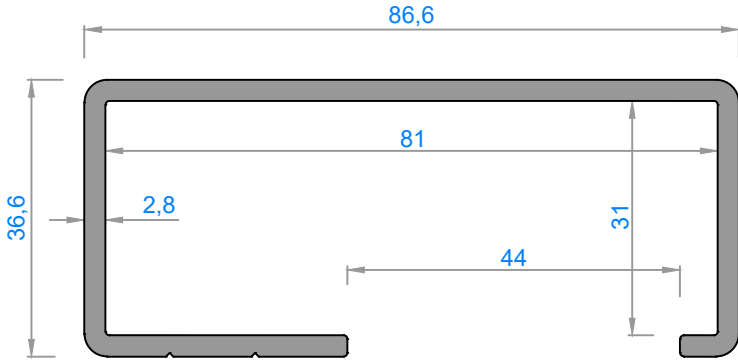

4294 - 1,428 kg/m

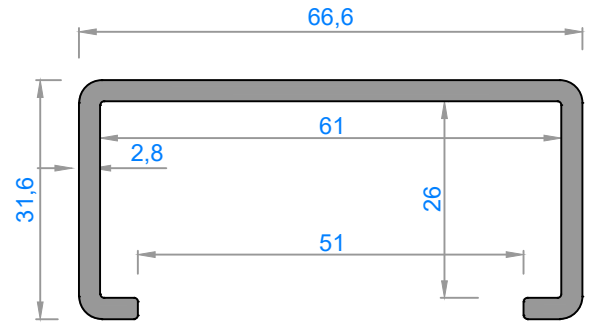

4293 - 0,997 kg/m

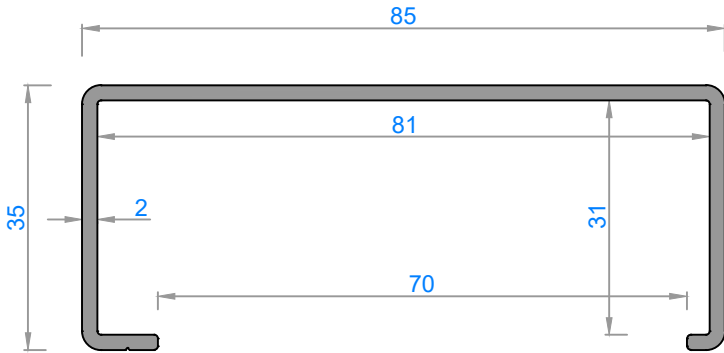

4341 - 0,863 kg/m

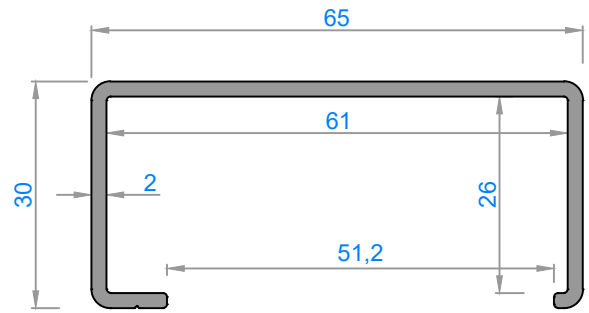

4340 - 0,694 kg/m

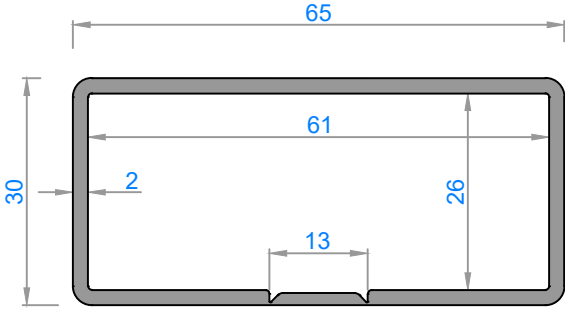

4343 - 0,953 kg/m

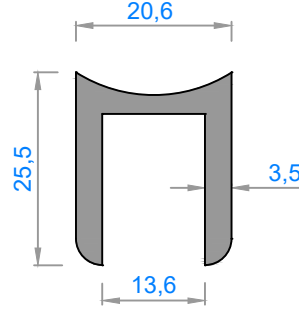

4284 - 0,558 kg/m

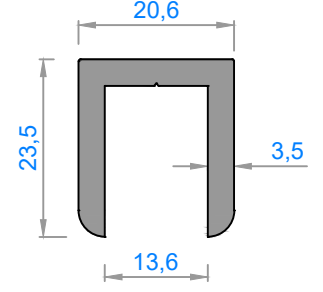

4321 - 0,560 kg/m

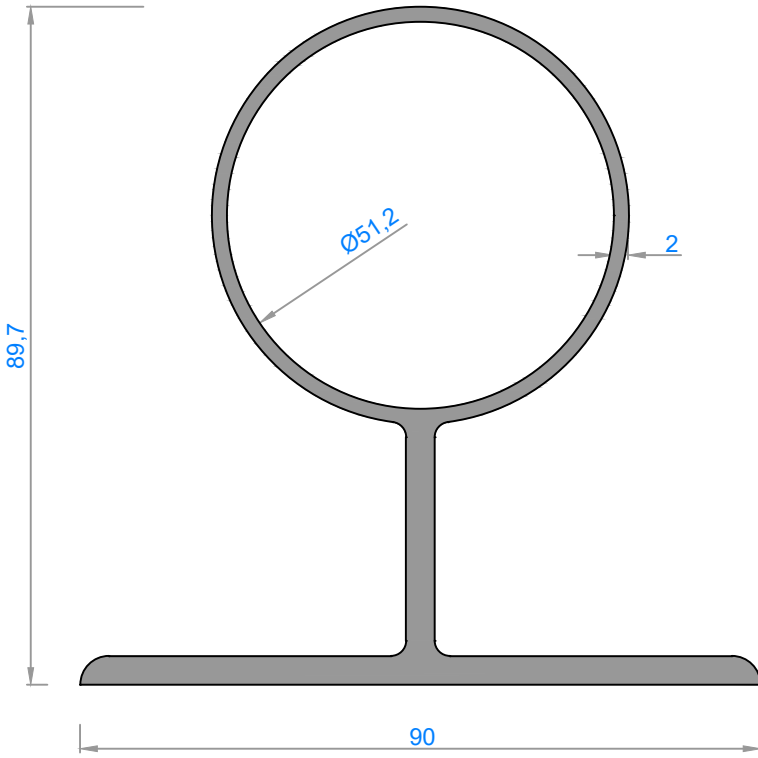

4285 - 2,140 kg/m

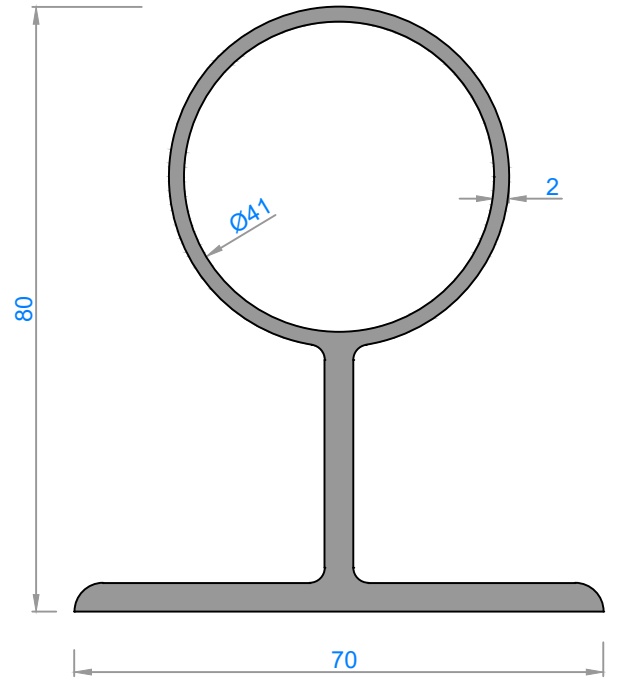

4286 - 1,765 kg/m

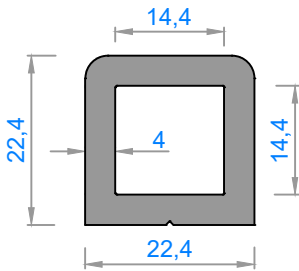

4373 - 0,787 kg/m

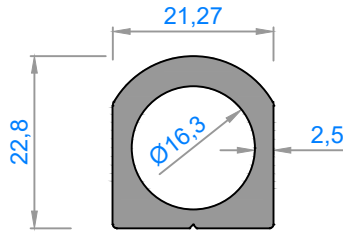

4374 - 0,645 kg/m

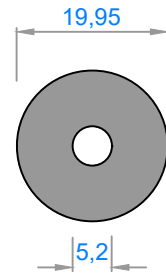

4364 - 0,789 kg/m

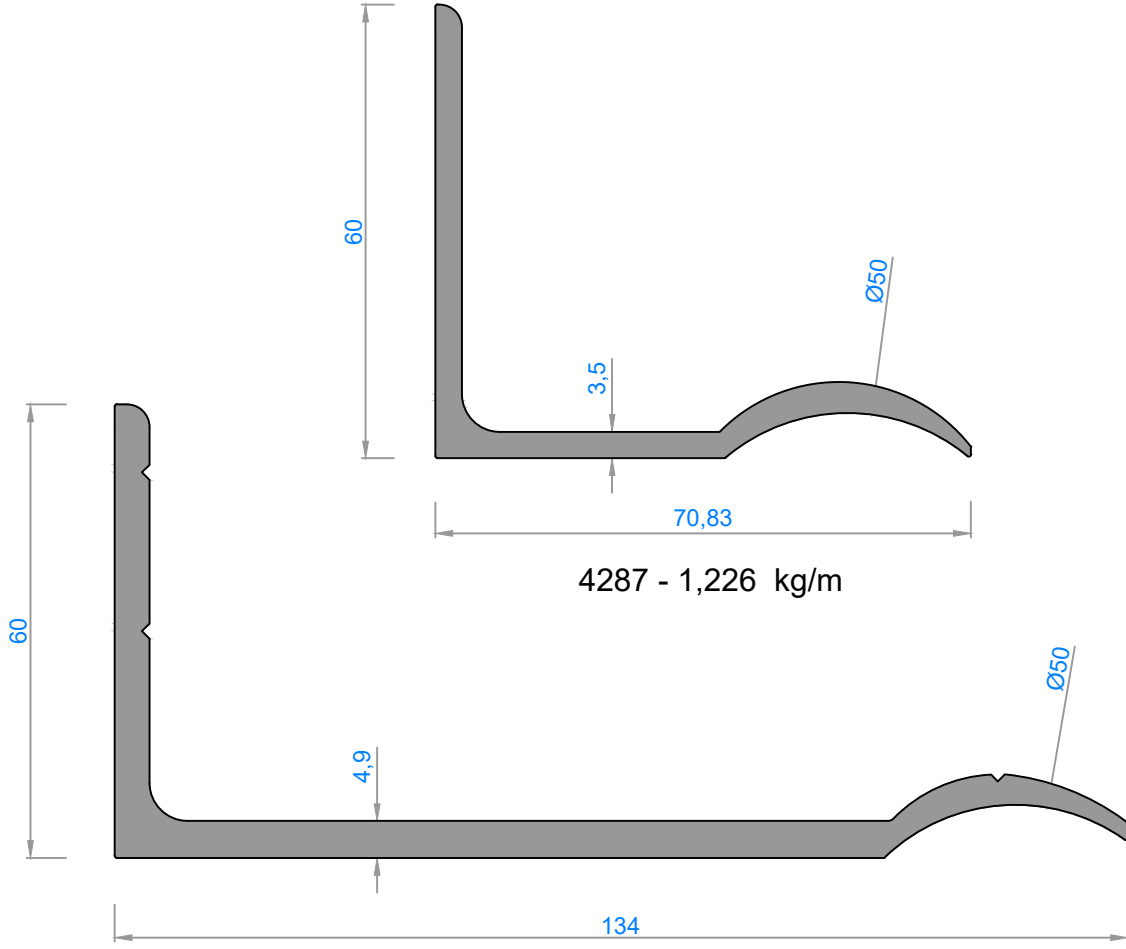

4288 - 2,367 kg/m

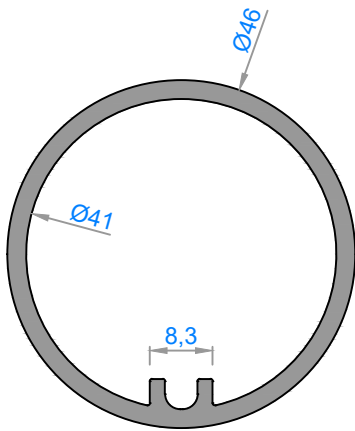

4290 - 0,971 g/m

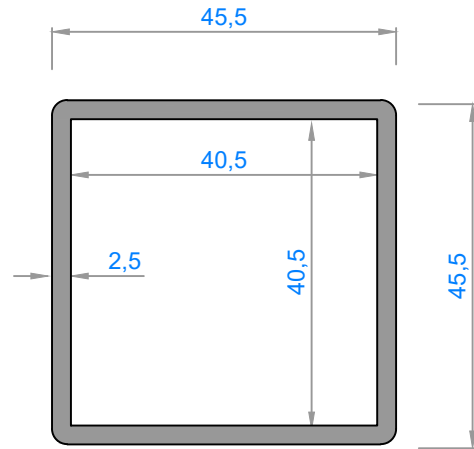

4548 - 1,156 kg/m

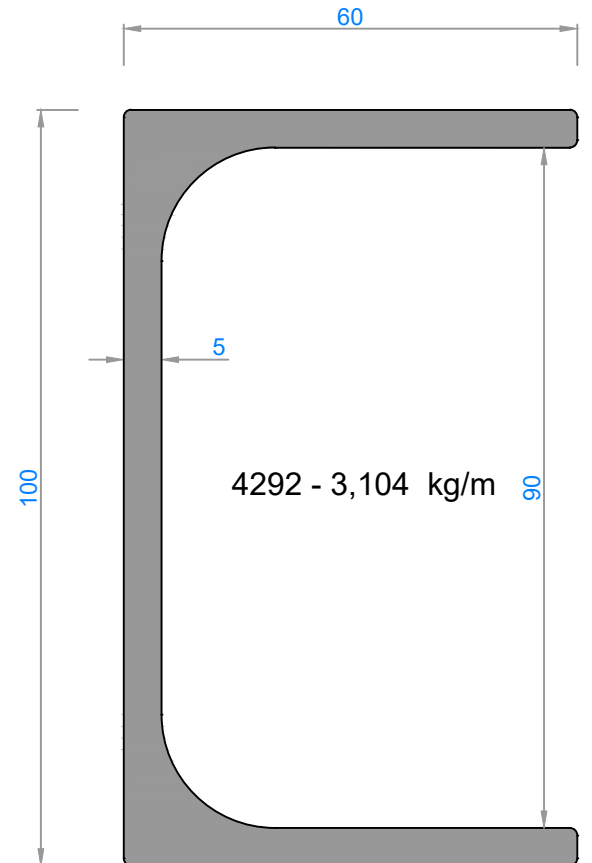
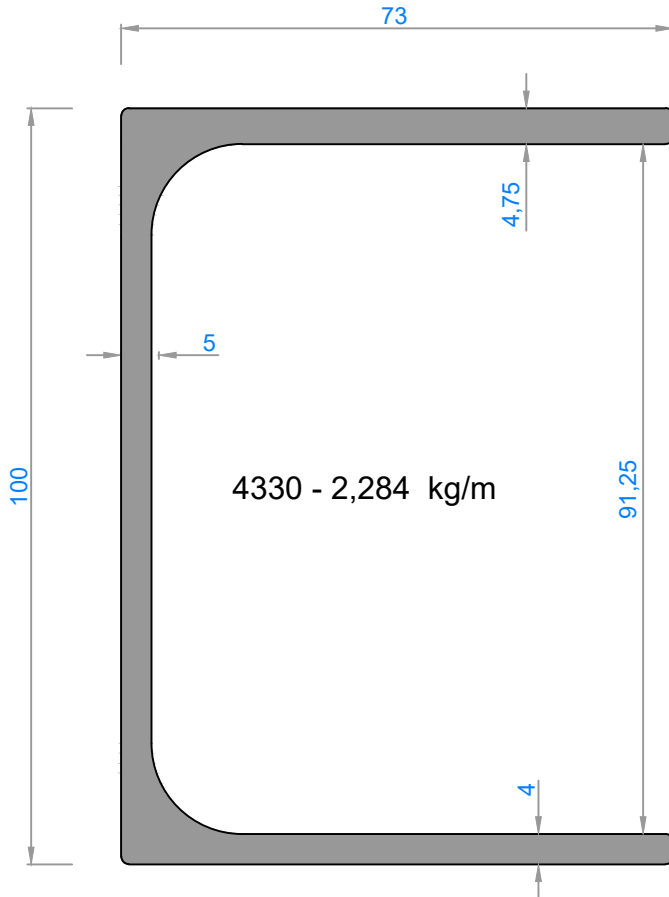
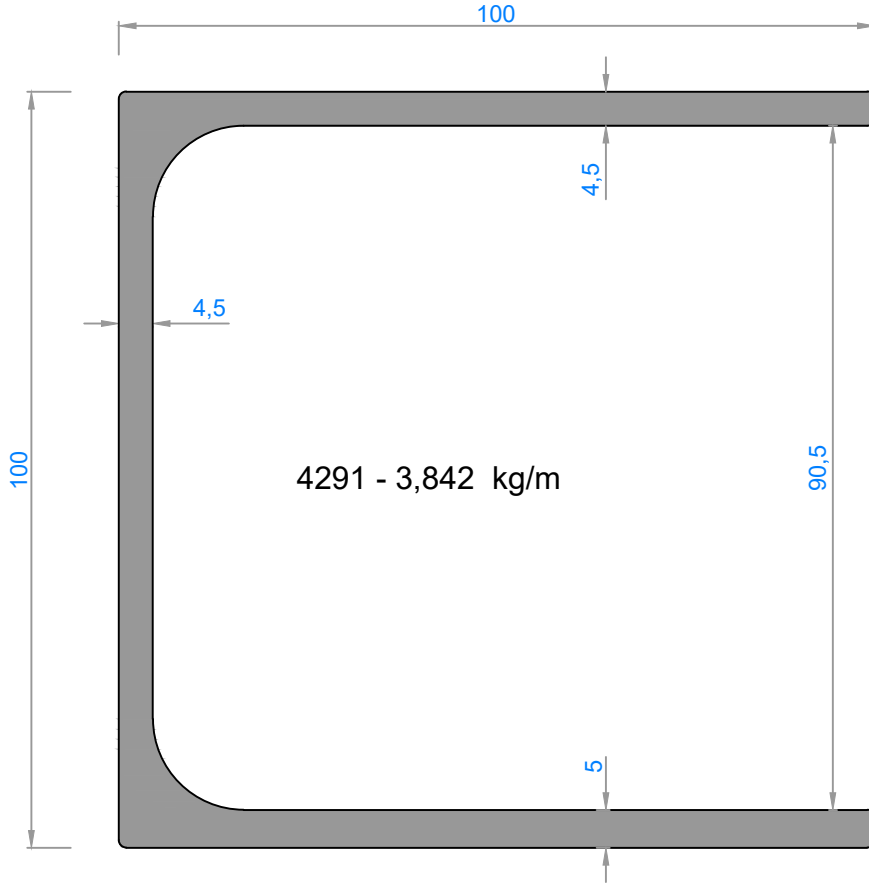

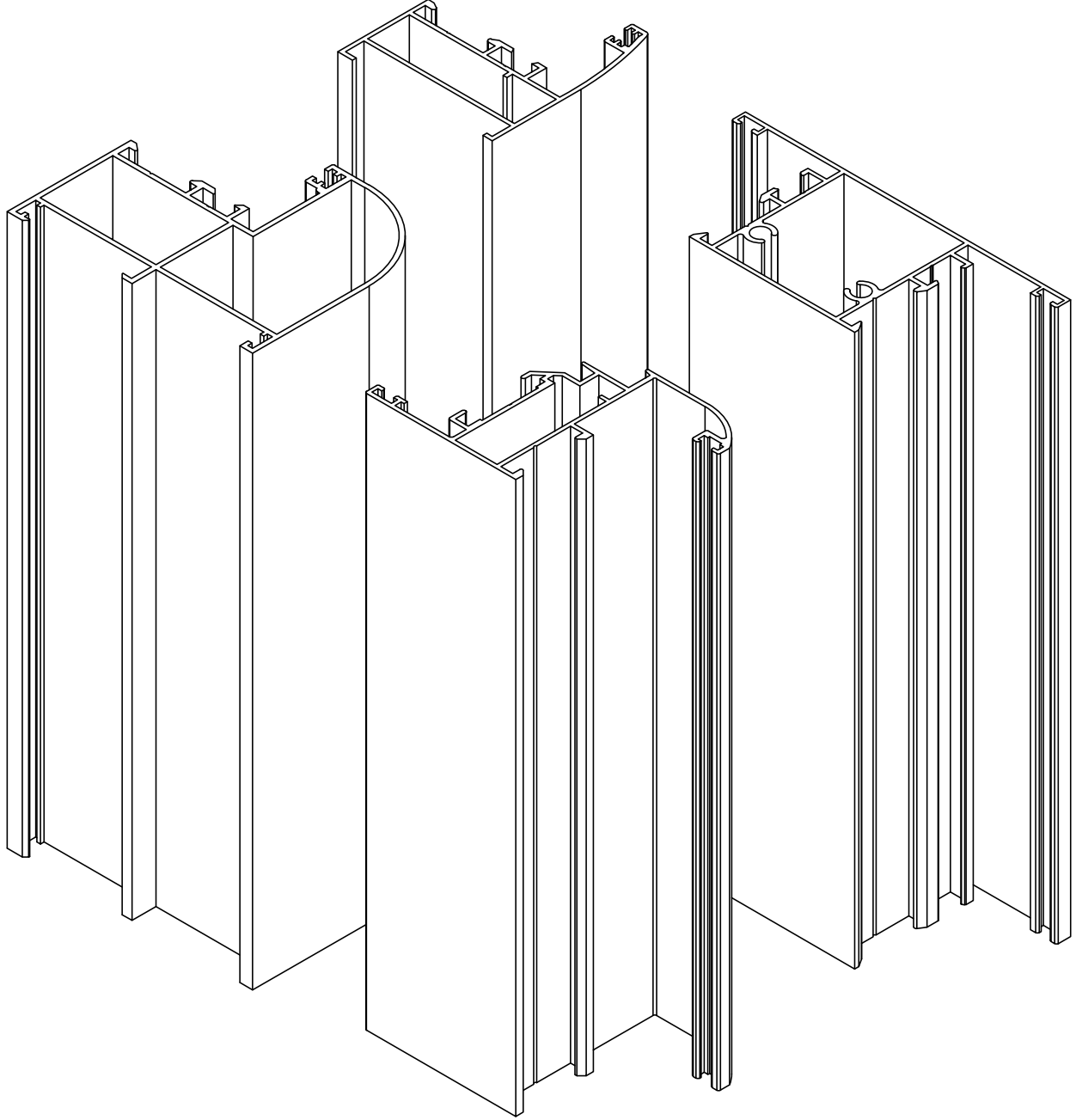

OVAL SERİ PROFİLLERİ / Oval Series Profiles

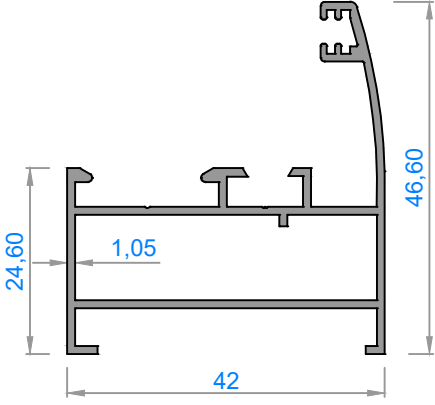

1304 - 0,550 kg/m

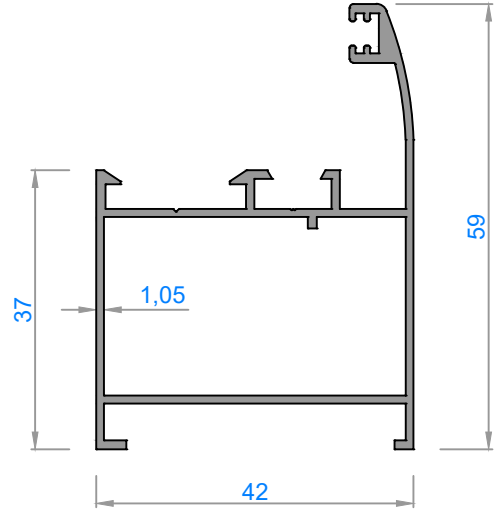

1303 - 0,630 kg/m

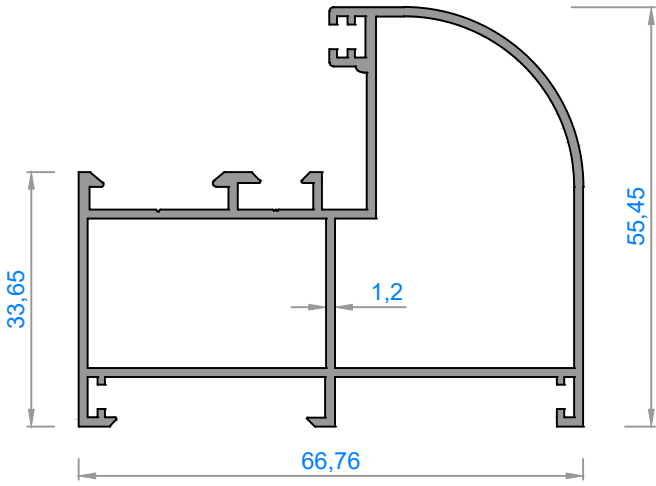

1326 - 1,000 kg/m

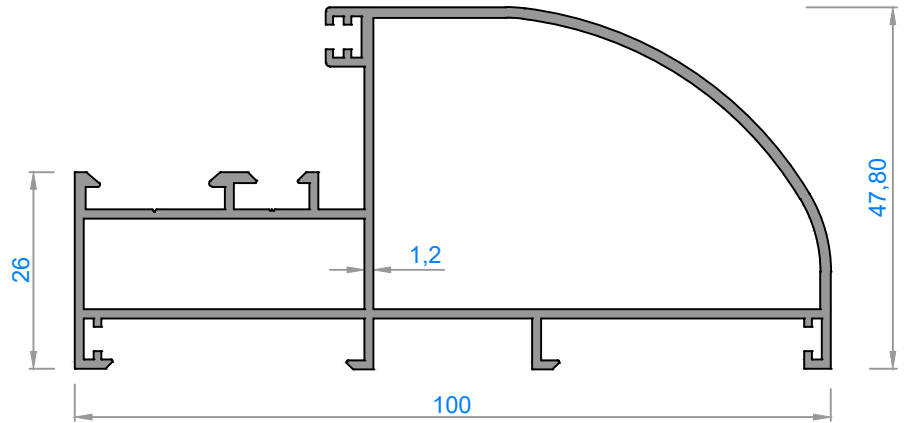

1325 - 1,190 kg/m

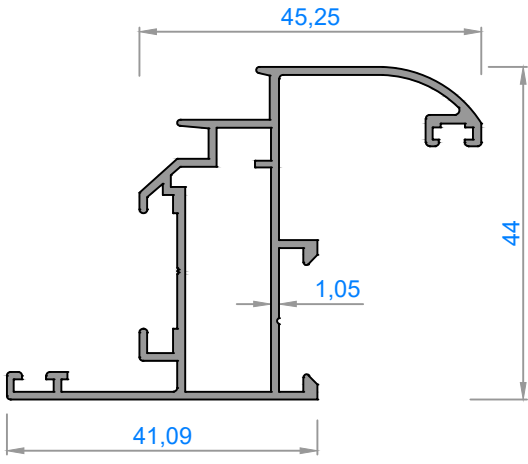

1302 - 0,632 kg/m

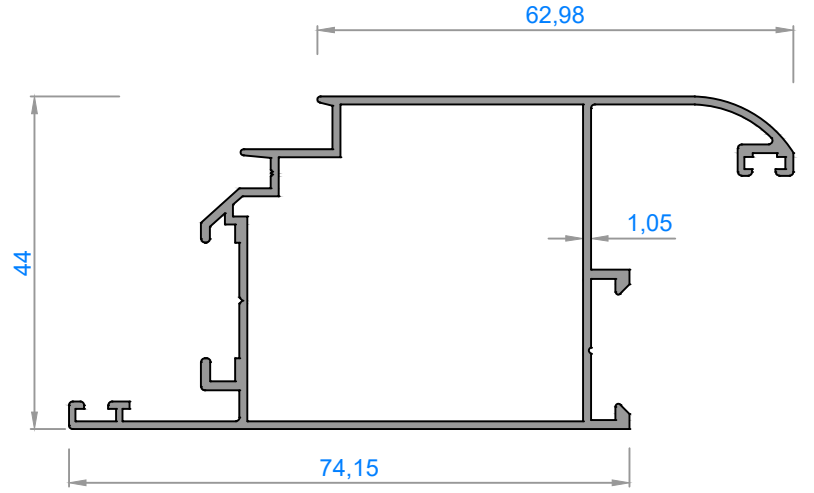

1308 - 0,840 kg/m

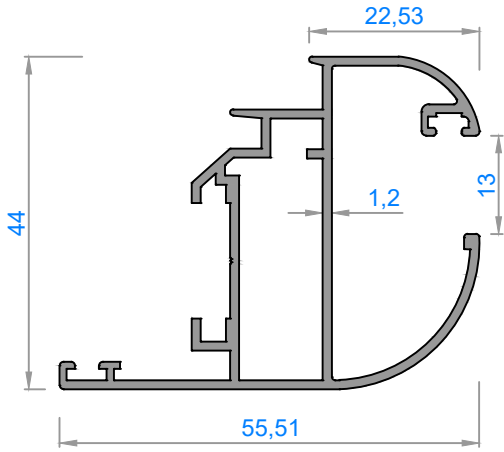

1300 - 0,730 kg/m

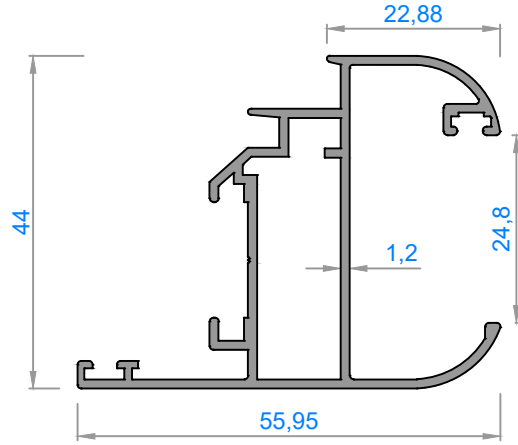

1301 - 0,705 kg/m

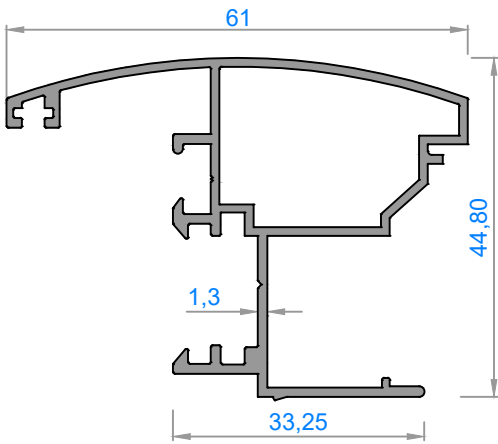

1305 - 0,725 kg/m

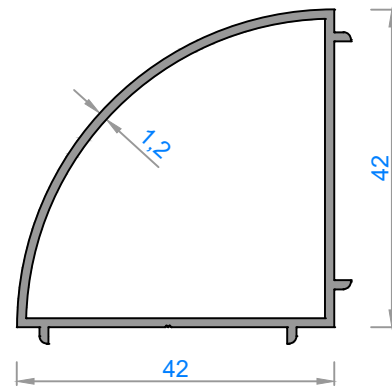

1327 - 0,500 kg/m

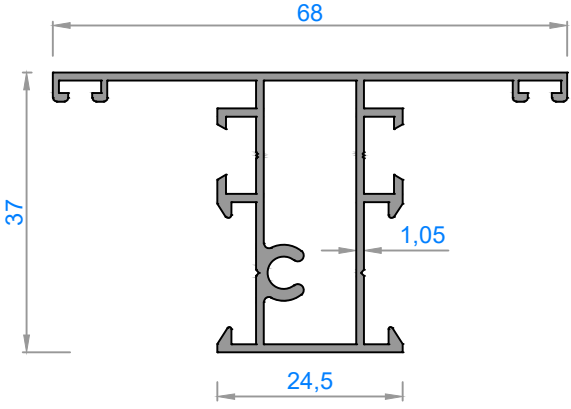

1307 - 0,665 kg/m

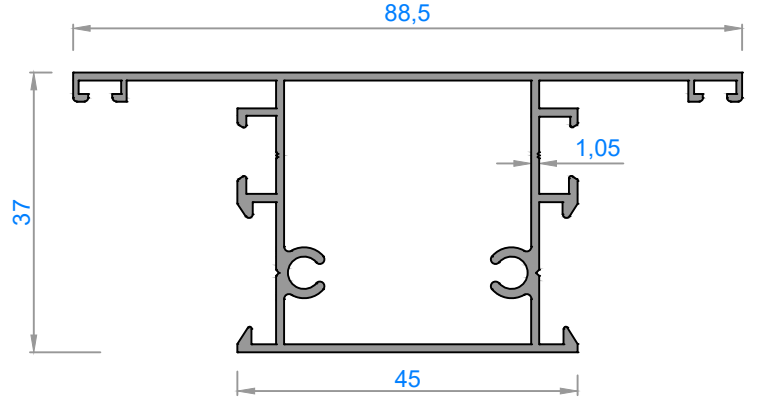

1306 - 0,810 kg/m

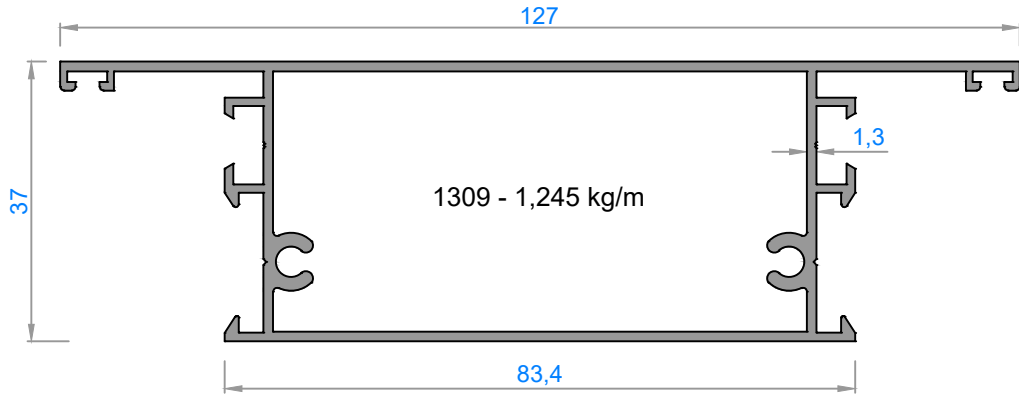

1309 - 1,245 kg/m

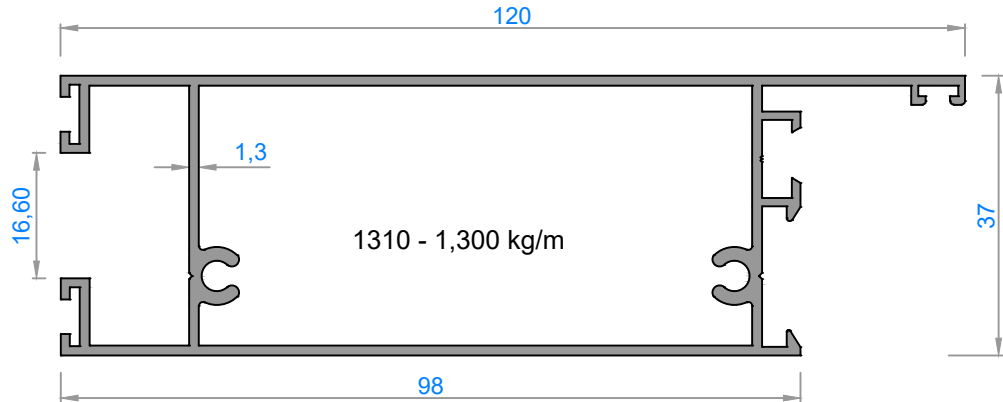

1310 - 1,300 kg/m

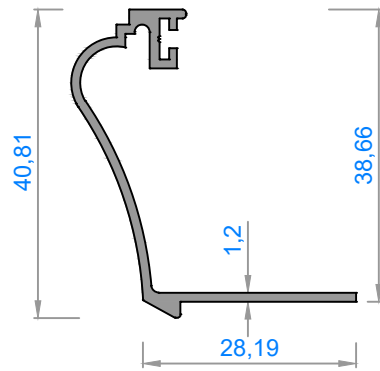
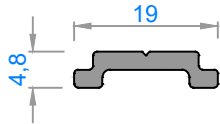
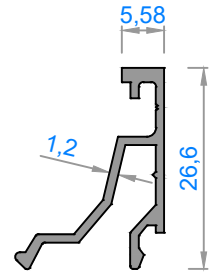
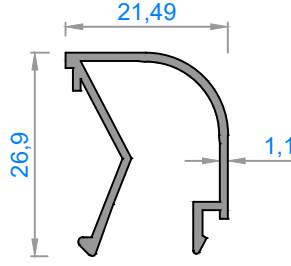
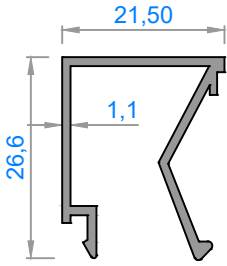
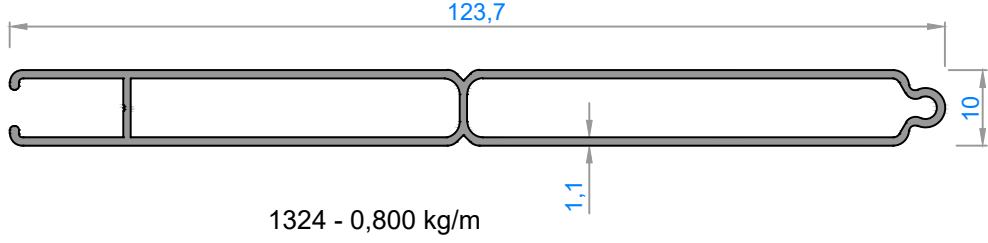

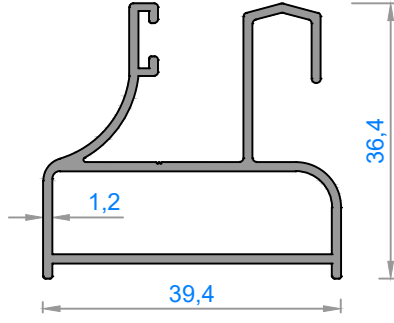

1318 - 0,560 kg/m

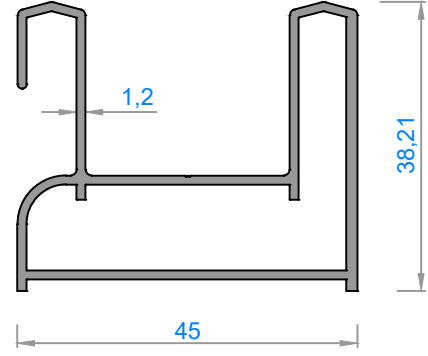

1317 - 0,685 kg/m

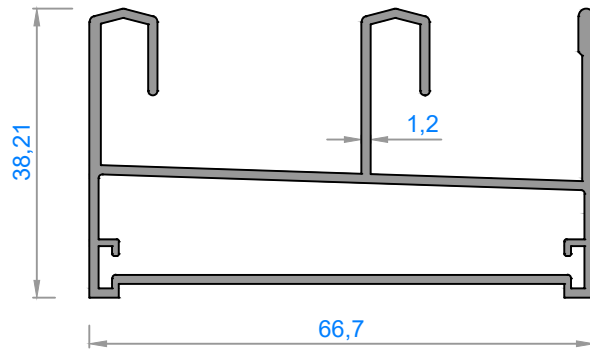

1316 - 0,915 kg/m

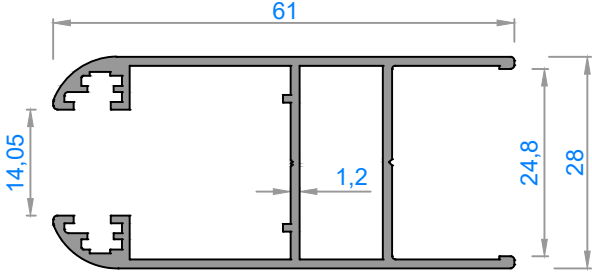

1311 - 0,675 kg/m

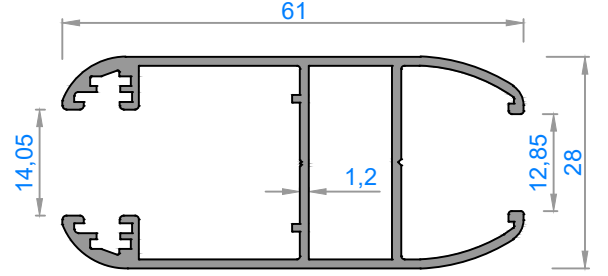

1312 - 0,670 kg/m

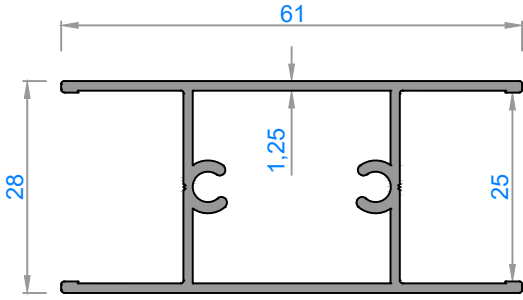

1313 - 0,665 kg/m

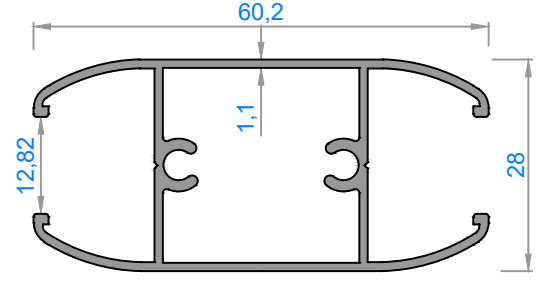

1314 - 0,658 kg/m

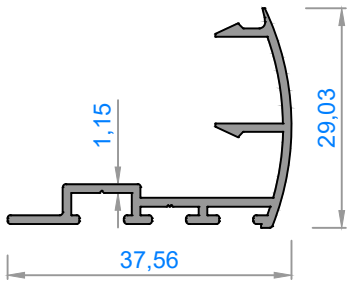

1333 - 0,305 kg/m

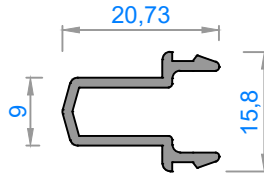

1337 - 0,190 kg/m

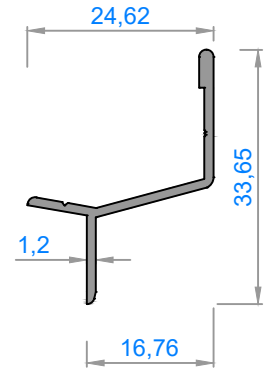

1330 - 0,182 kg/m

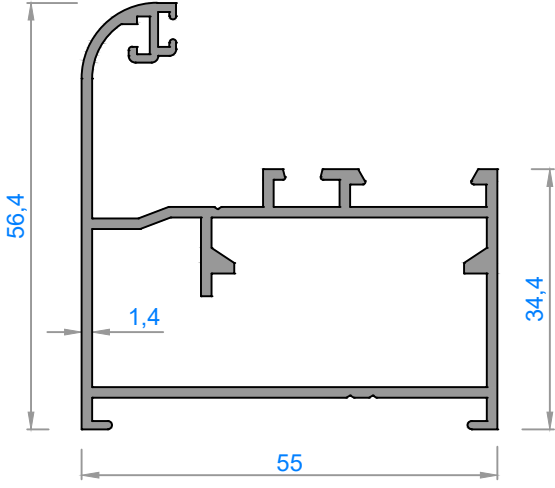

2989 - 0,980 kg/m

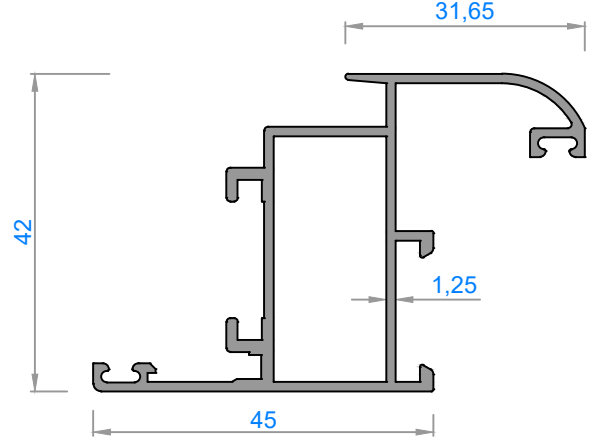

2988 - 0,745 kg/m

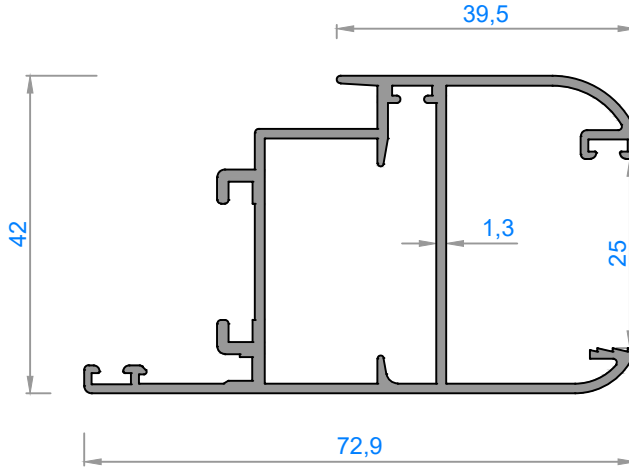

3057 - 0,935 kg/m

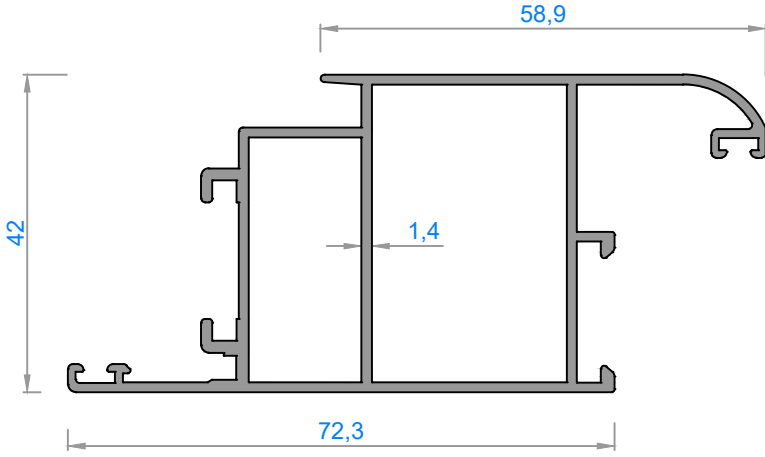

2943 - 1,105 kg/m

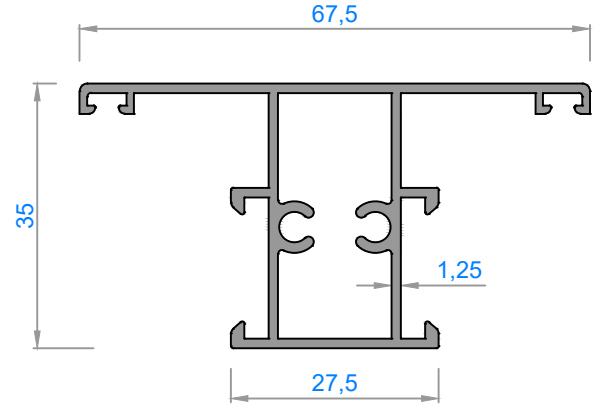

3006 - 0,735 kg/m

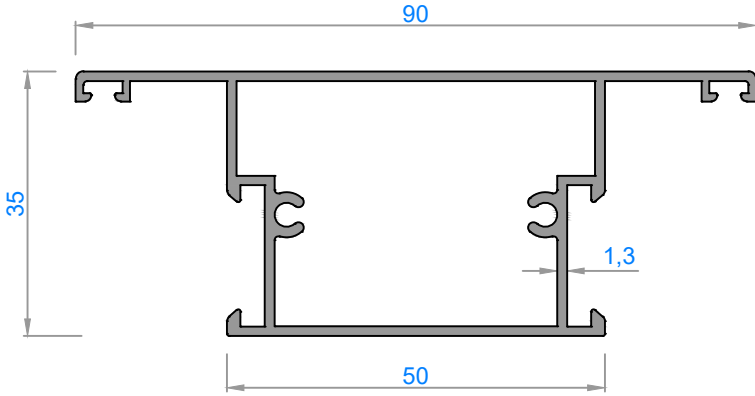

3007 - 0,895 kg/m

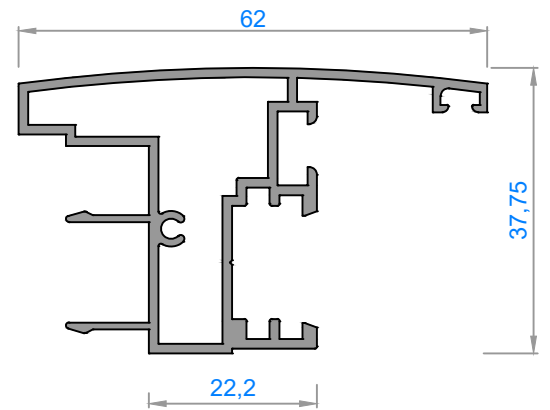

3008 - 0,805 kg/m

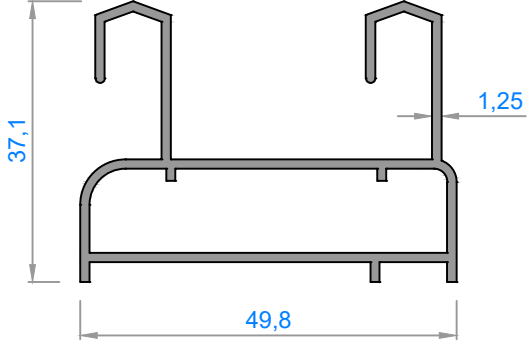

3013 - 0,684 kg/m

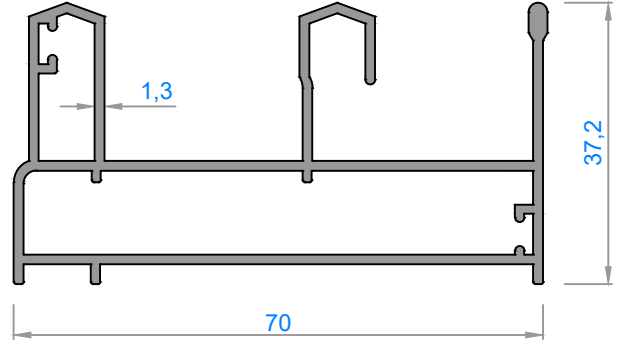

3016 - 1,014 kg/m

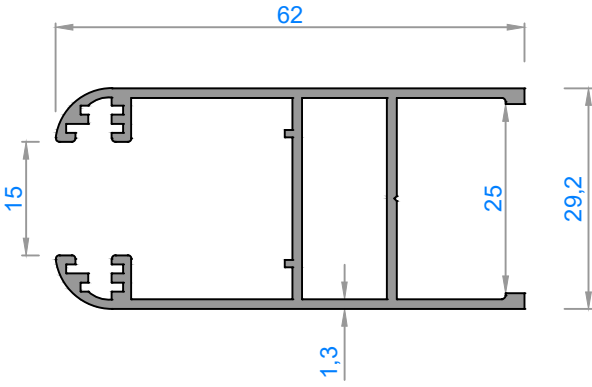

3017 - 0,745 kg/m

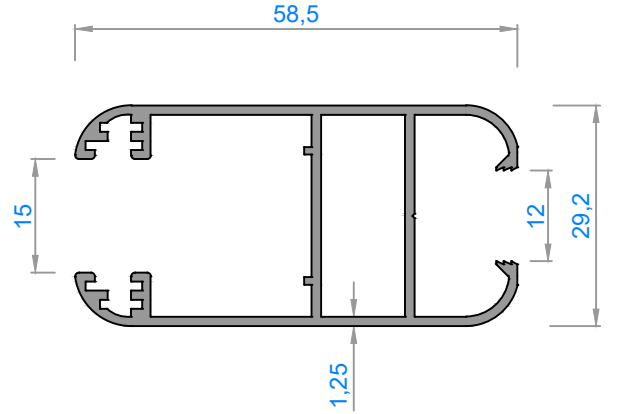

3014 - 0,723 kg/m

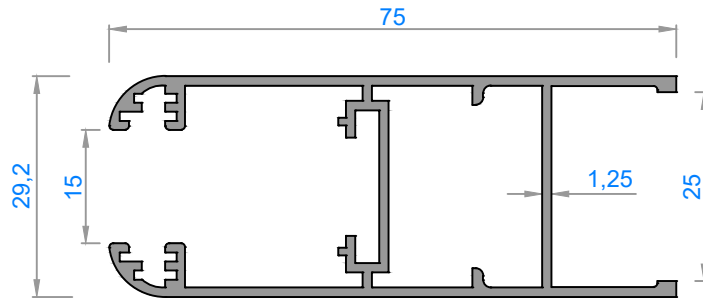

2987 - 0,890 kg/m

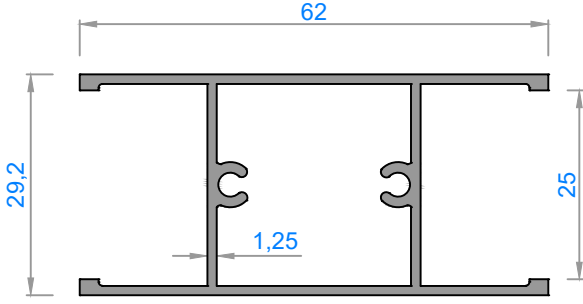

3116 - 0,695 kg/m

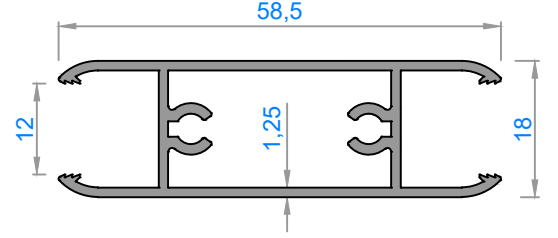

3058 - 0,605 kg/m

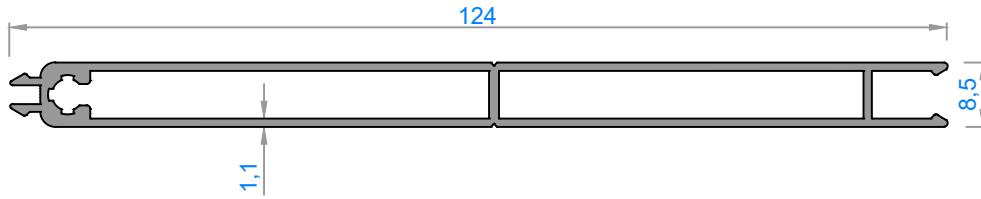

3035 - 0,840 kg/m

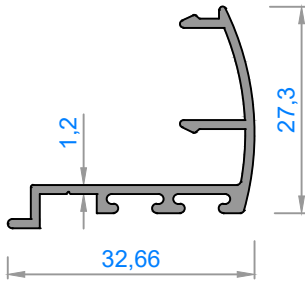

3015 - 0,300 kg/m

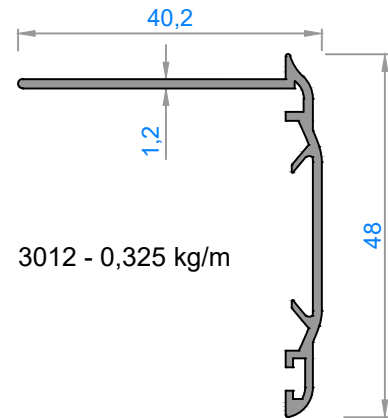

3012 - 0,325 kg/m

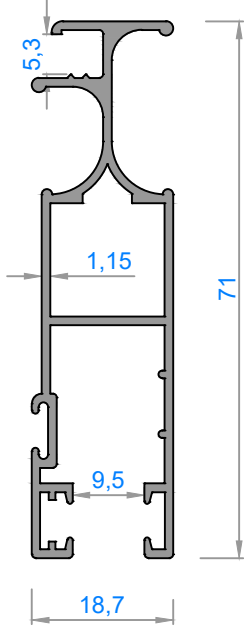

3022 - 0,665 kg/m

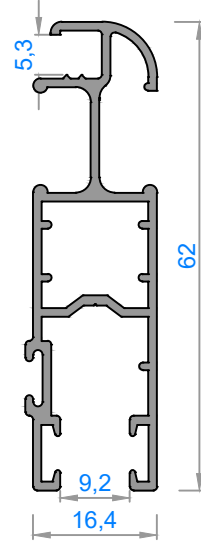

3018 - 0,630 kg/m

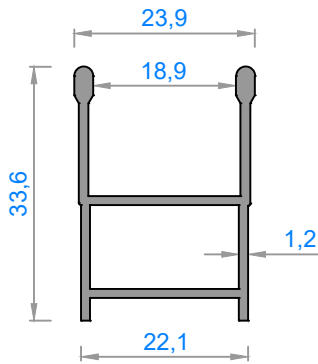

3020 - 0,385 kg/m

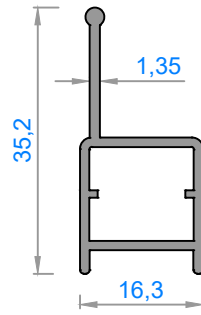

3019 - 0,290 kg/m

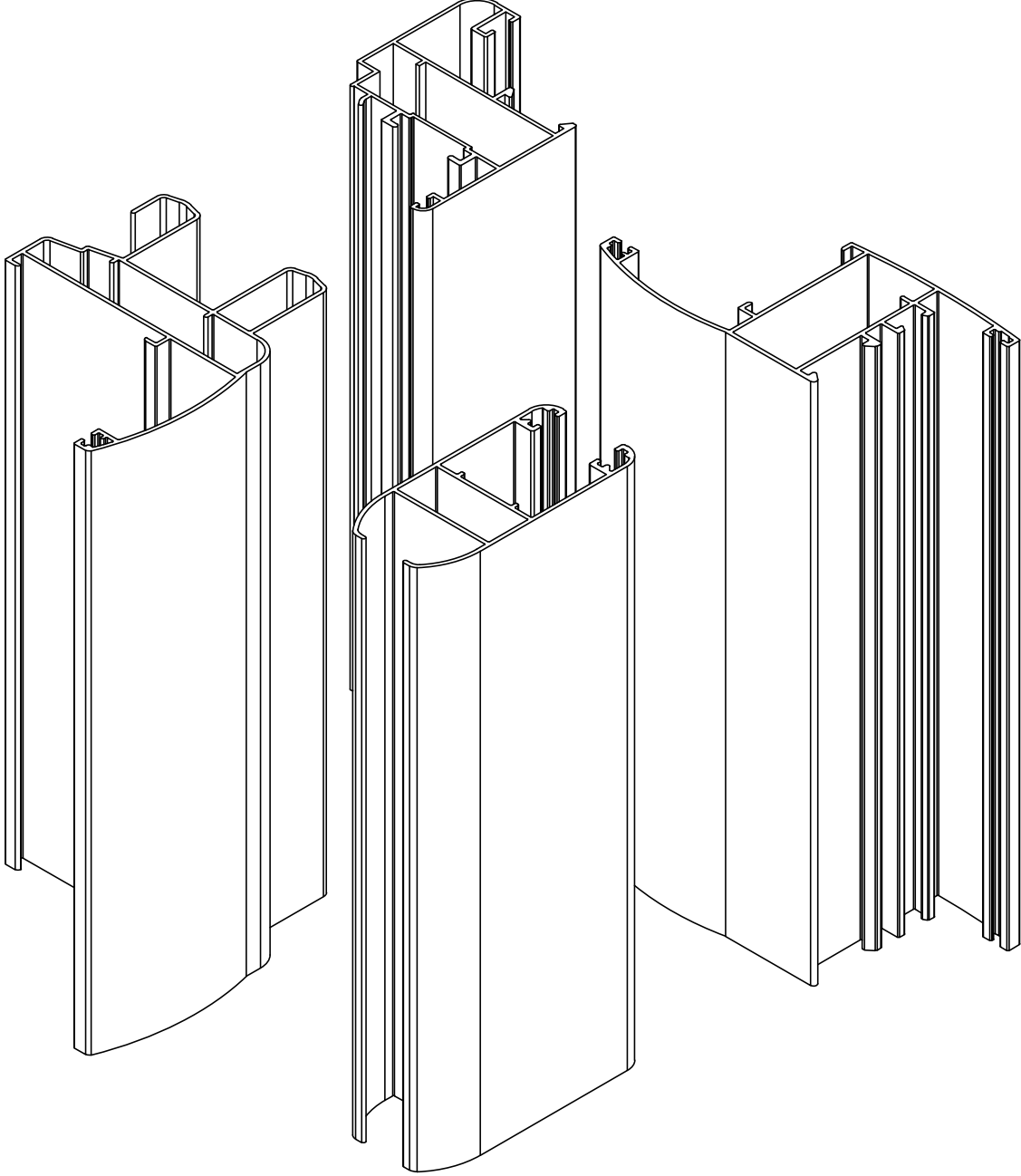

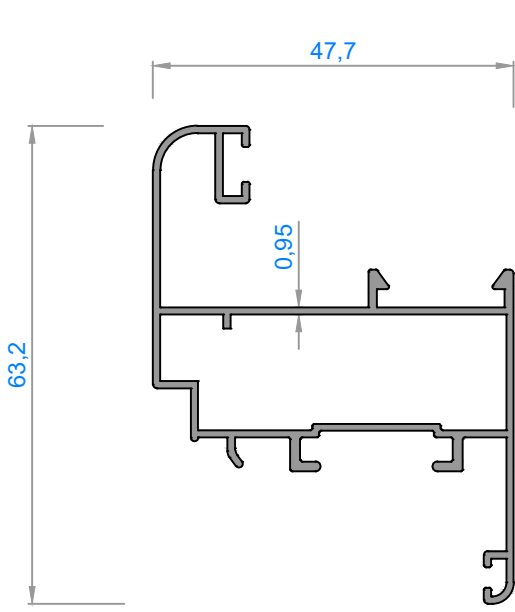

2595 - 0,643 kg/m

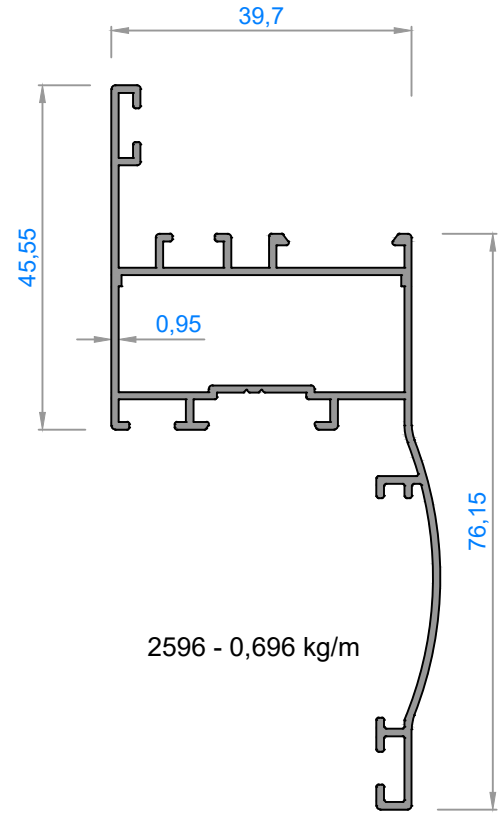

2596 - 0,696 kg/m

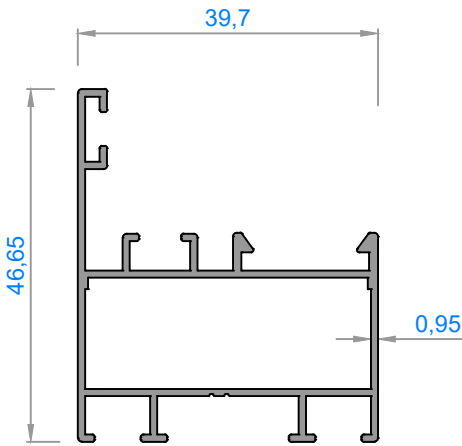

2597 - 0,526 kg/m

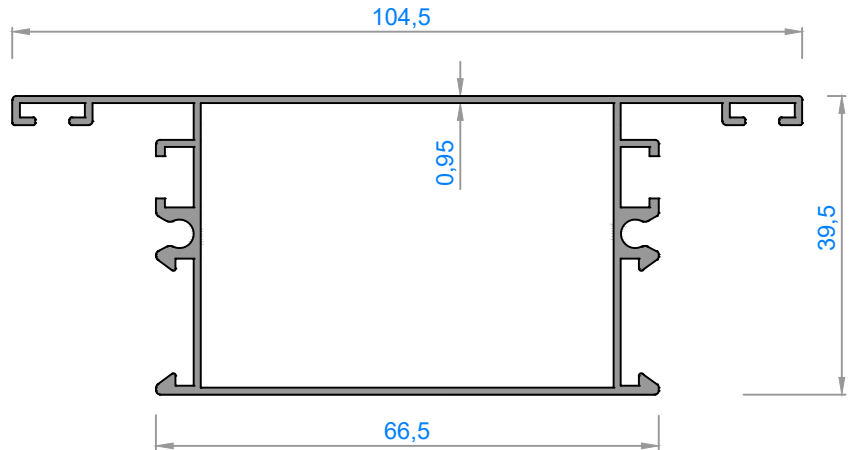

2598 - 0,848 kg/m

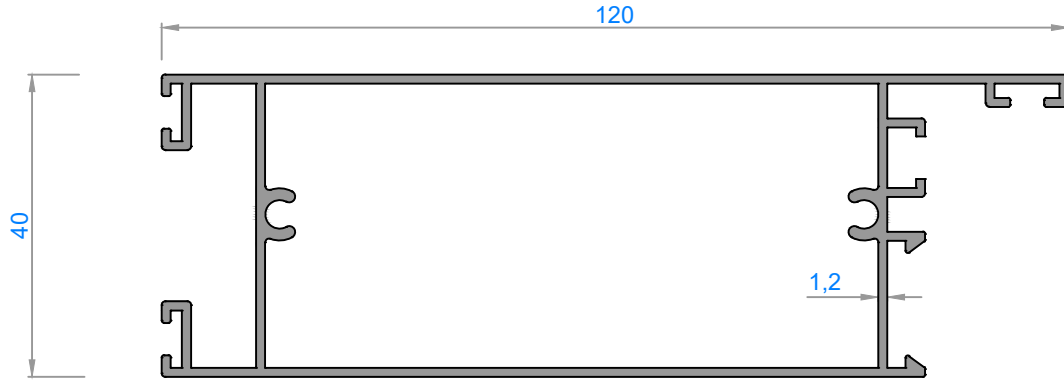

2599 - 1,230 kg/m

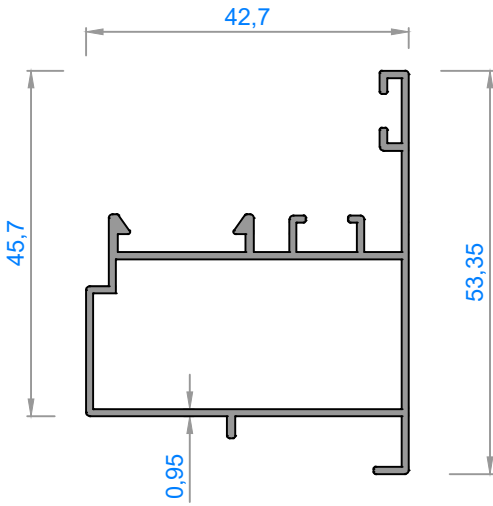

2600 - 0,520 kg/m

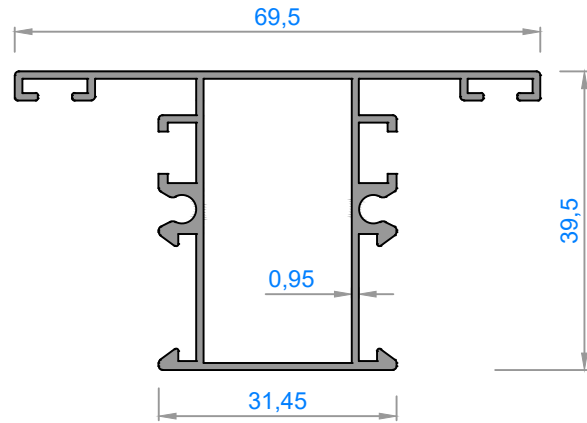

2601 - 0,667 kg/m

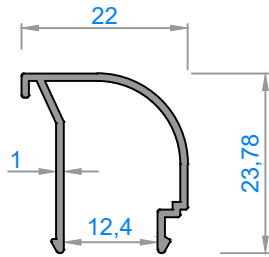

2602 - 0,190 kg/m

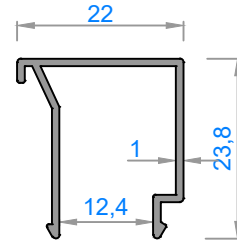

2603 - 0,200 kg/m

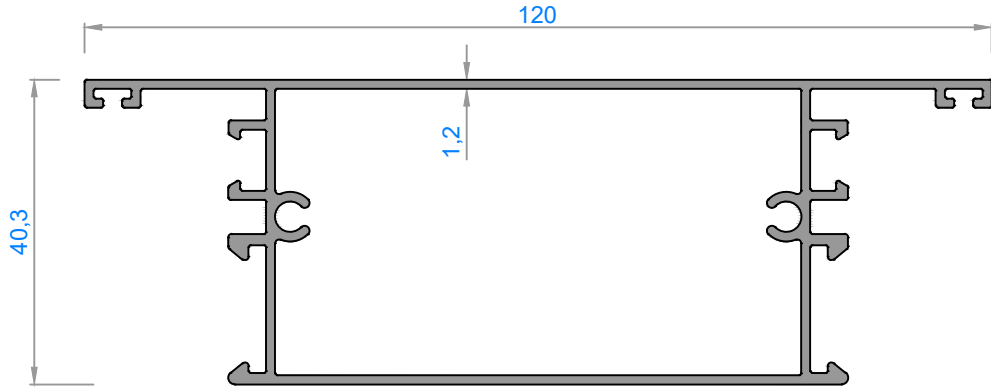

3457 - 1,184 kg/m

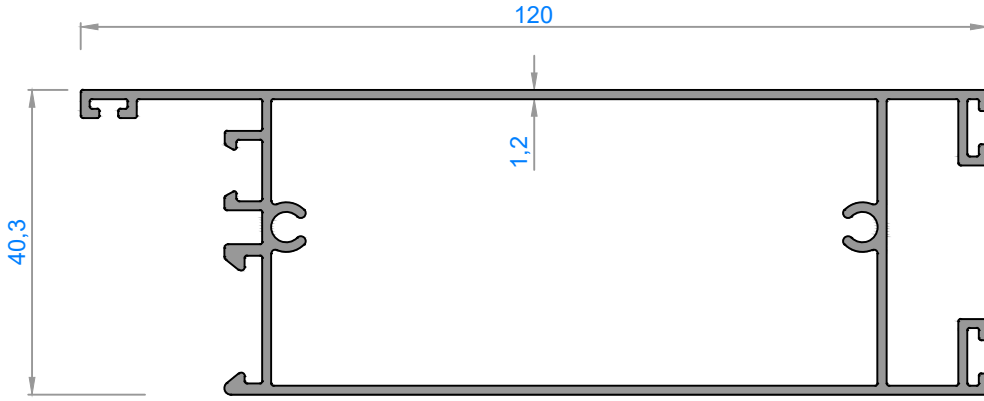

3458 - 1,238 kg/m

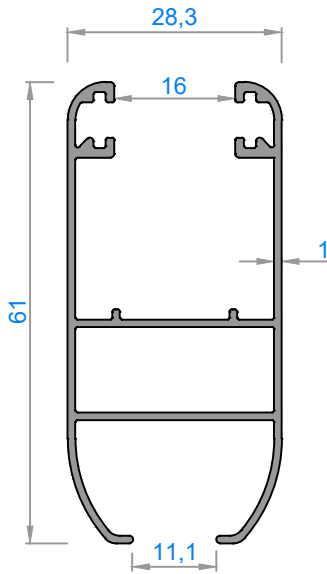

3459 - 0,590 kg/m

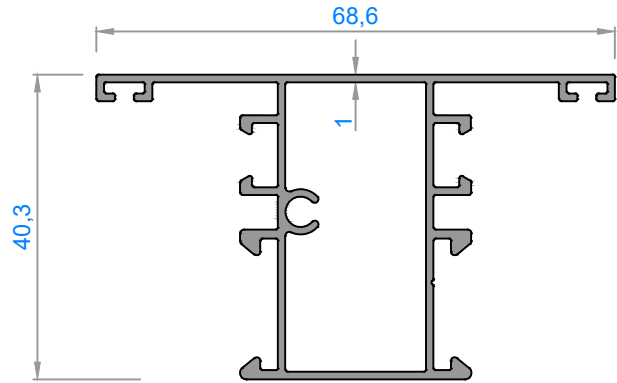

3460 - 0,696 kg/m

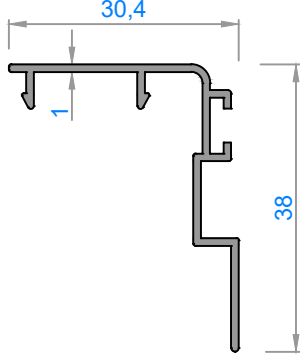

3461 - 0,235 kg/m

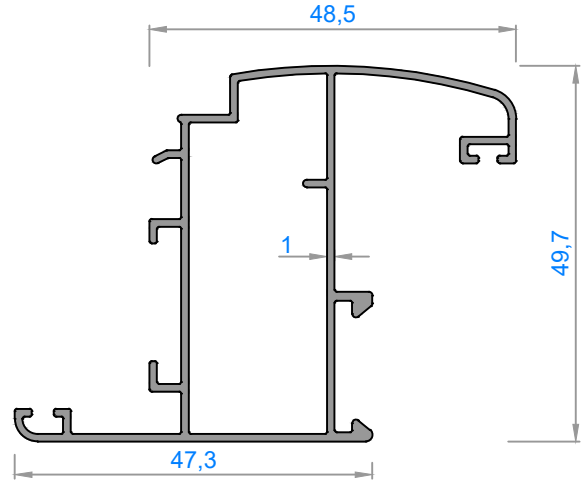

3462 - 0,672 kg/m

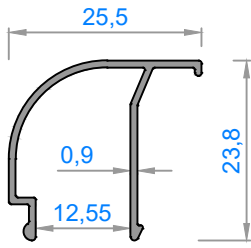

3463 - 0,173 kg/m

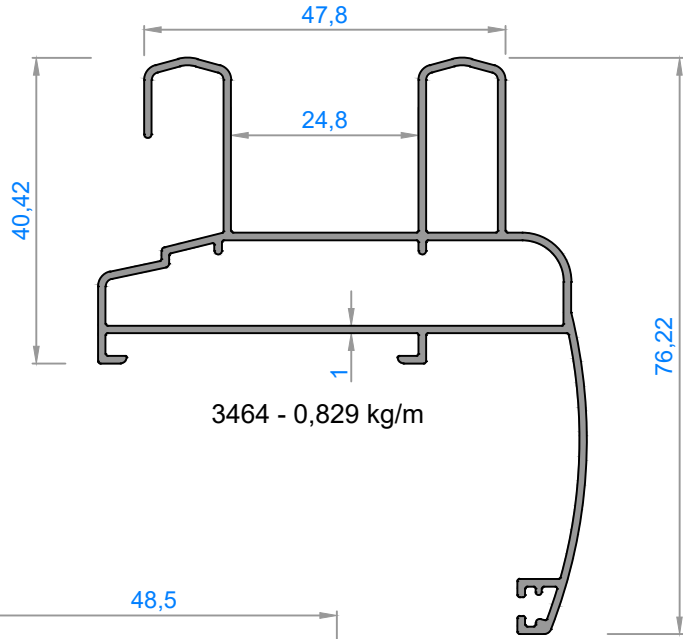

3464 - 0,829 kg/m

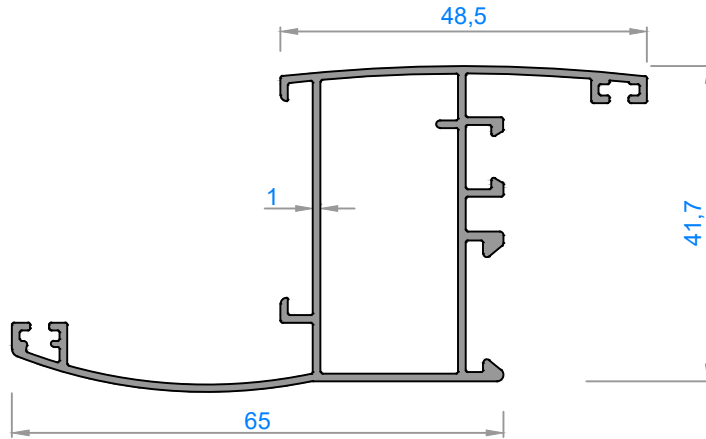

3465 - 0,691 kg/m

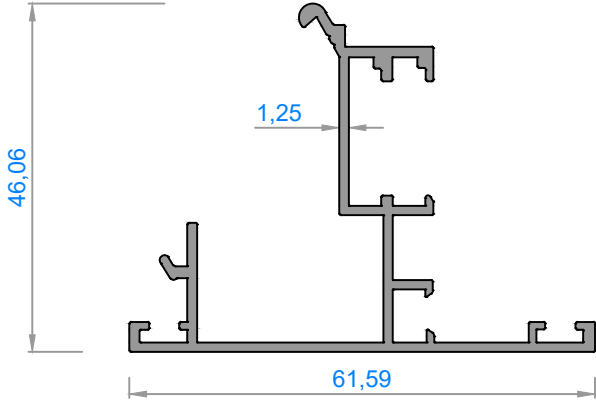

4083 - 0,640 kg/m

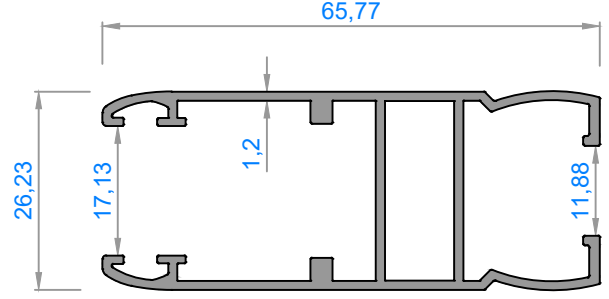

4084 - 0,747 kg/m

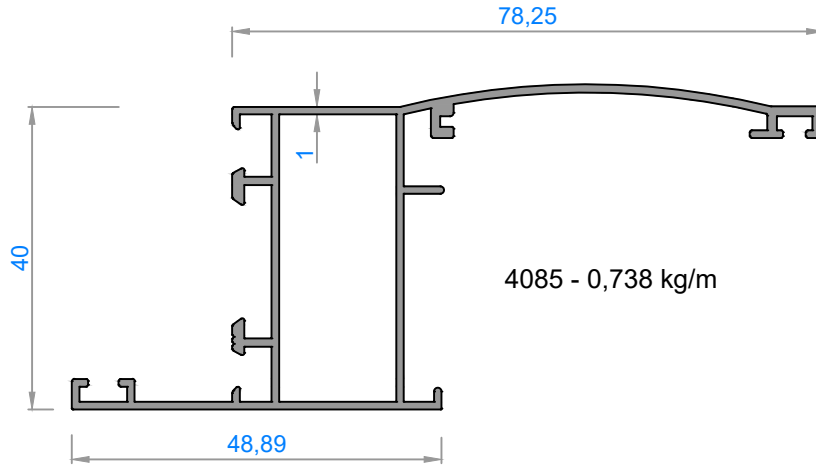

4085 - 0,738 kg/m

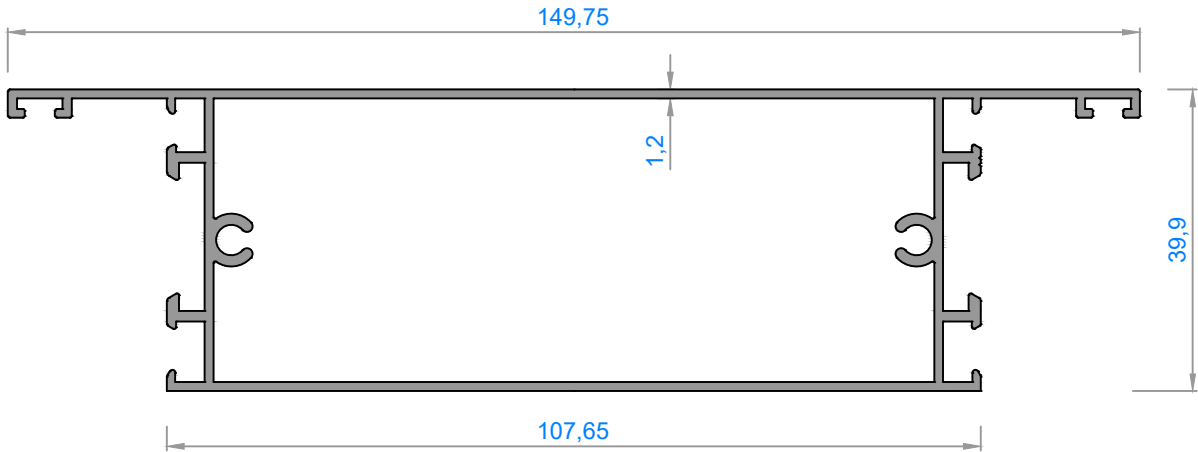

4086 - 1,351 kg/m

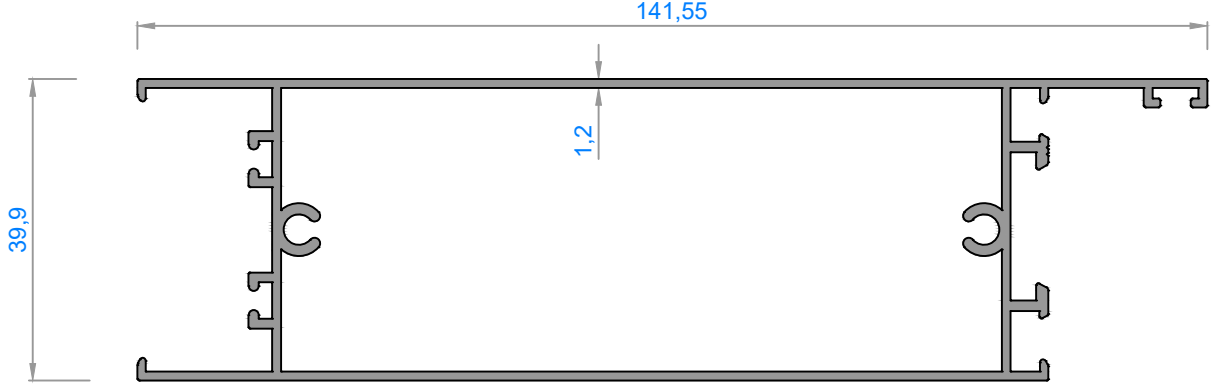

4087 - 1,343 kg/m

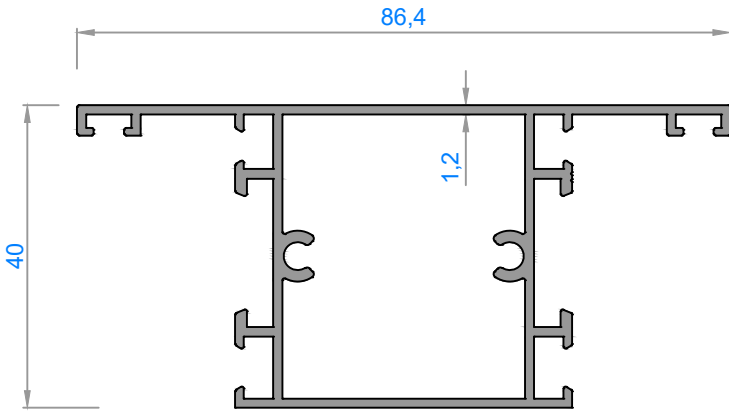

4088 - 0,932 kg/m

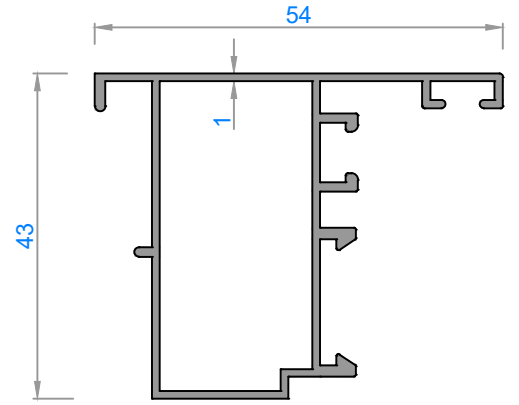

4089 - 0,575 kg/m

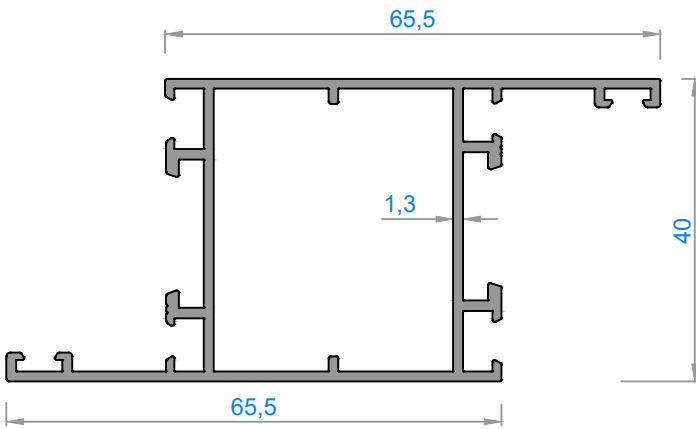

4090 - 0,931 kg/m

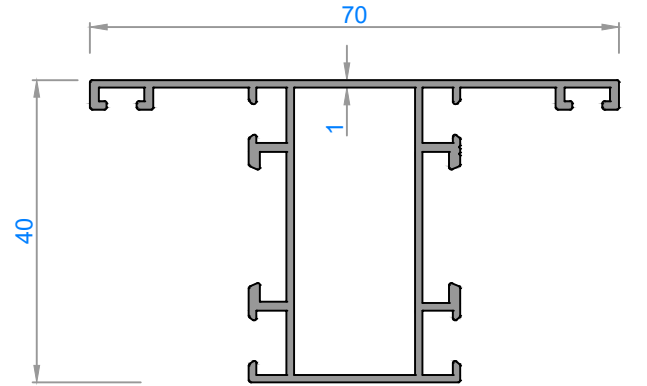

4091 - 0,650 kg/m

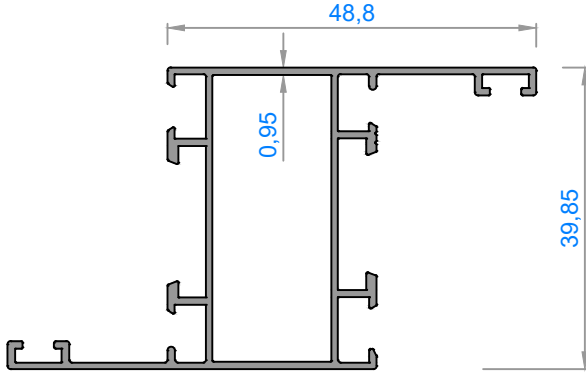

4092 - 0,564 kg/m

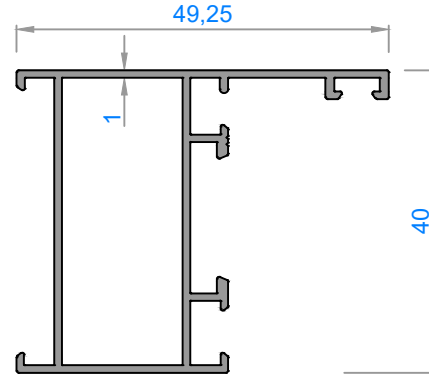

4093 - 0,504 kg/m

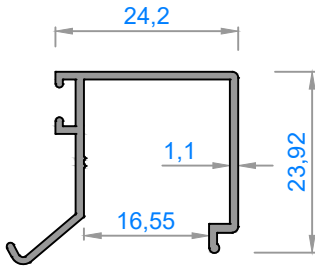

4094 - 0,244 kg/m

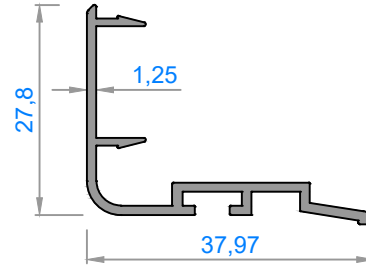

4095 - 0,288 kg/m

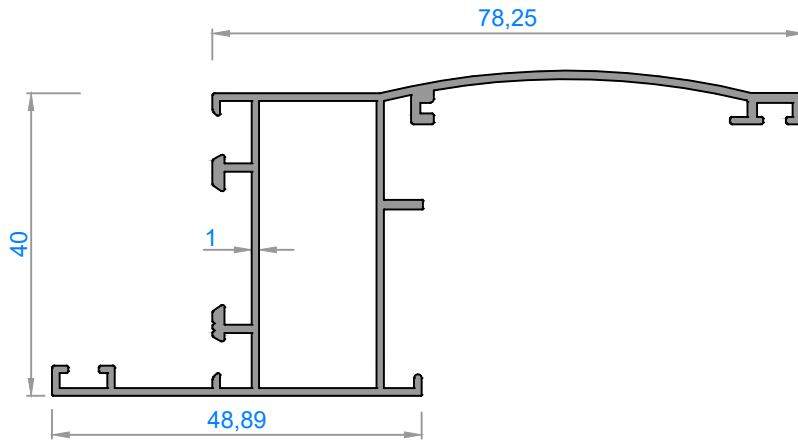

4096 - 0,742 kg/m

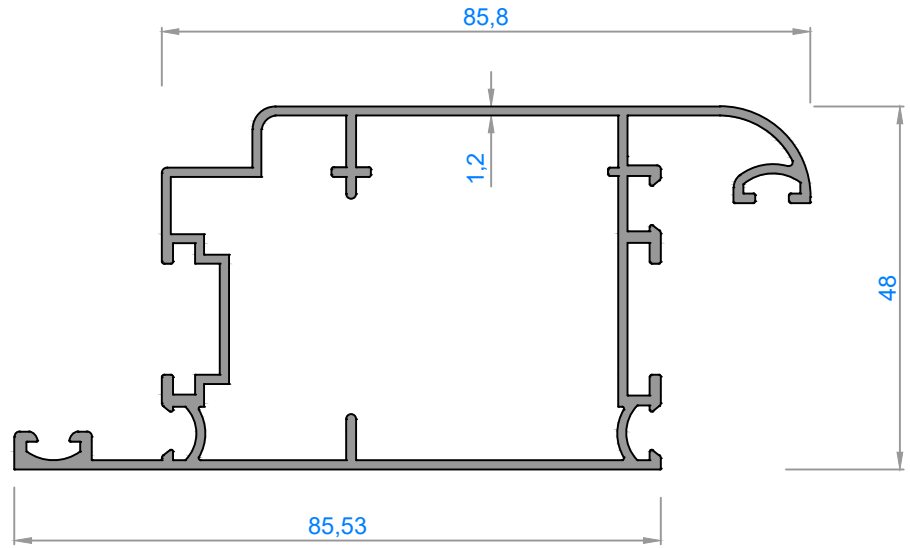
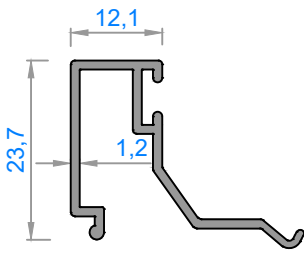
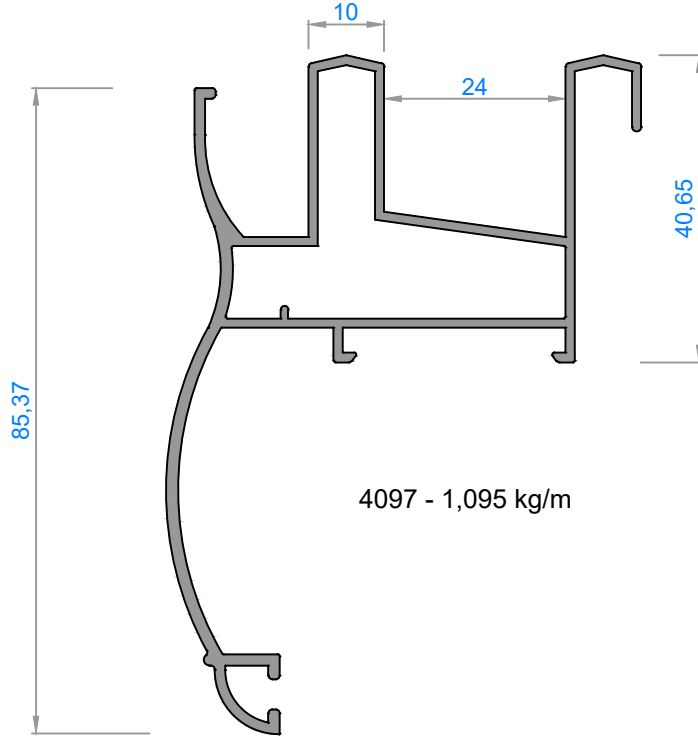

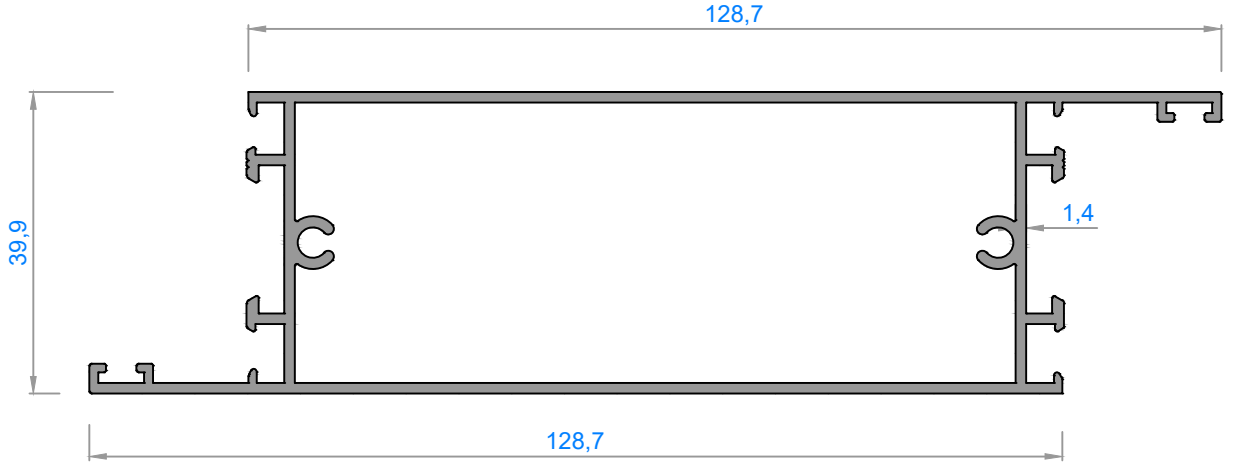

4870 - 1,540 kg/m

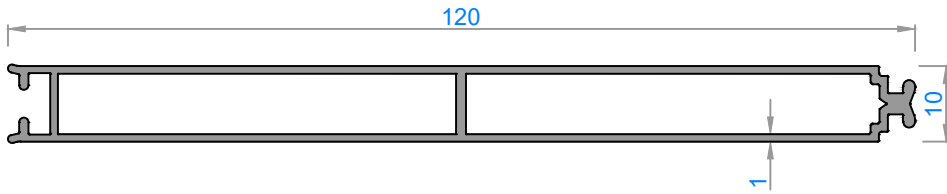

4159 - 0,755 kg/m

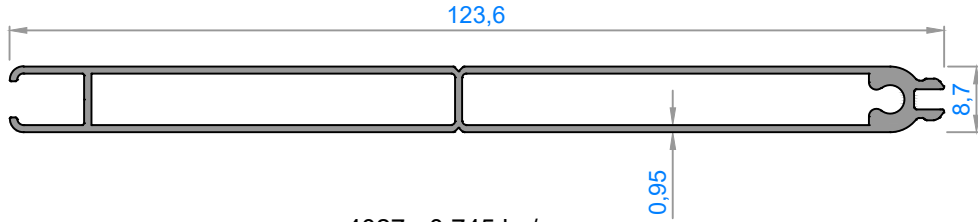

4027 - 0,745 kg/m

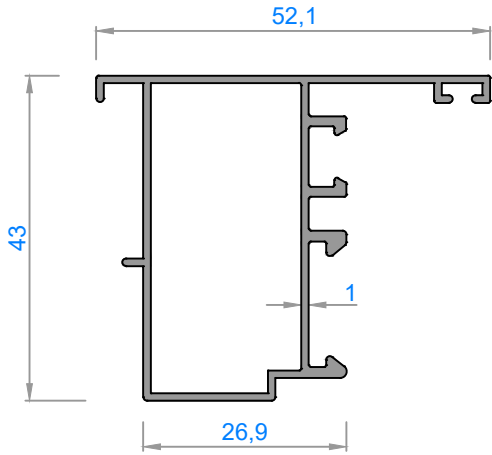

3477 - 0,558 kg/m

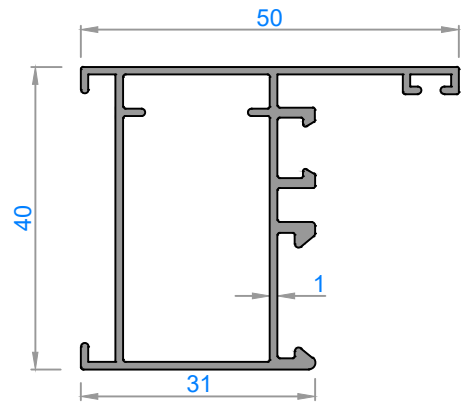

3476 - 0,560 kg/m

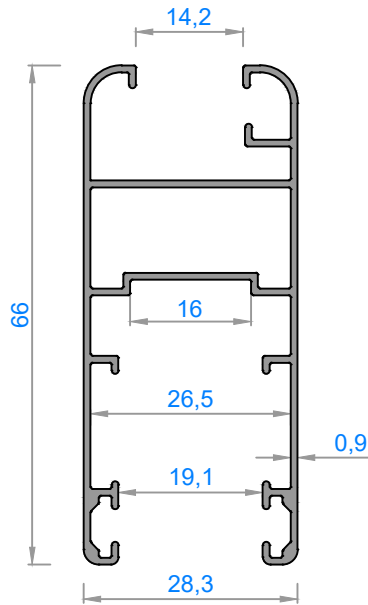
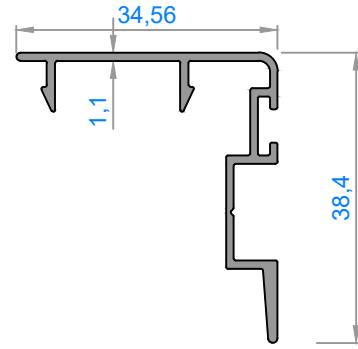
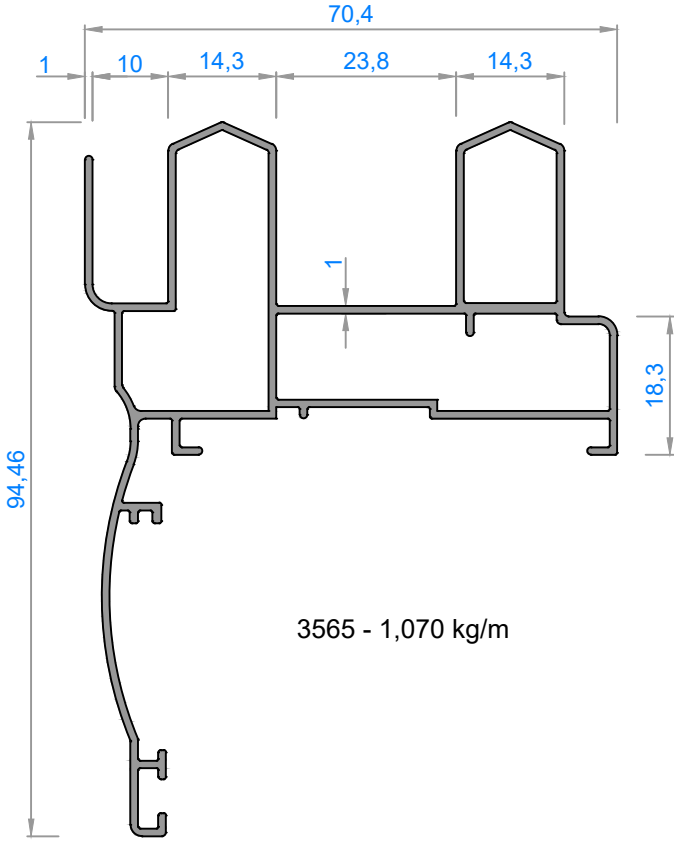

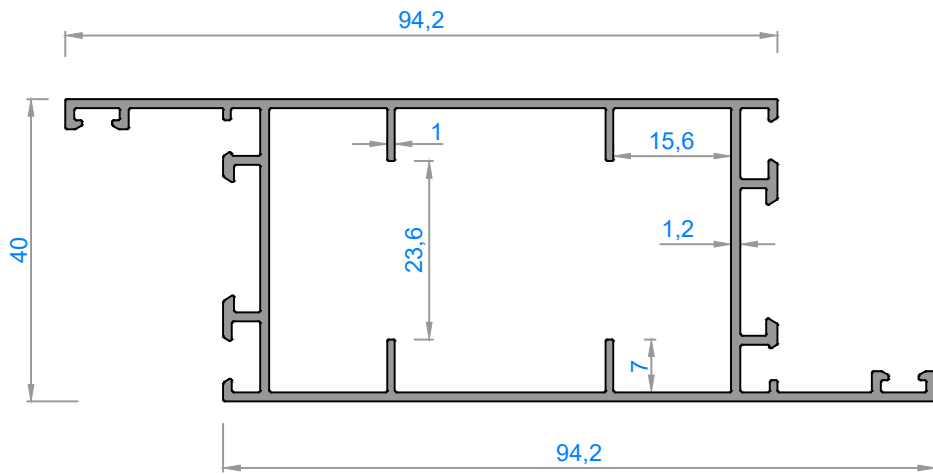
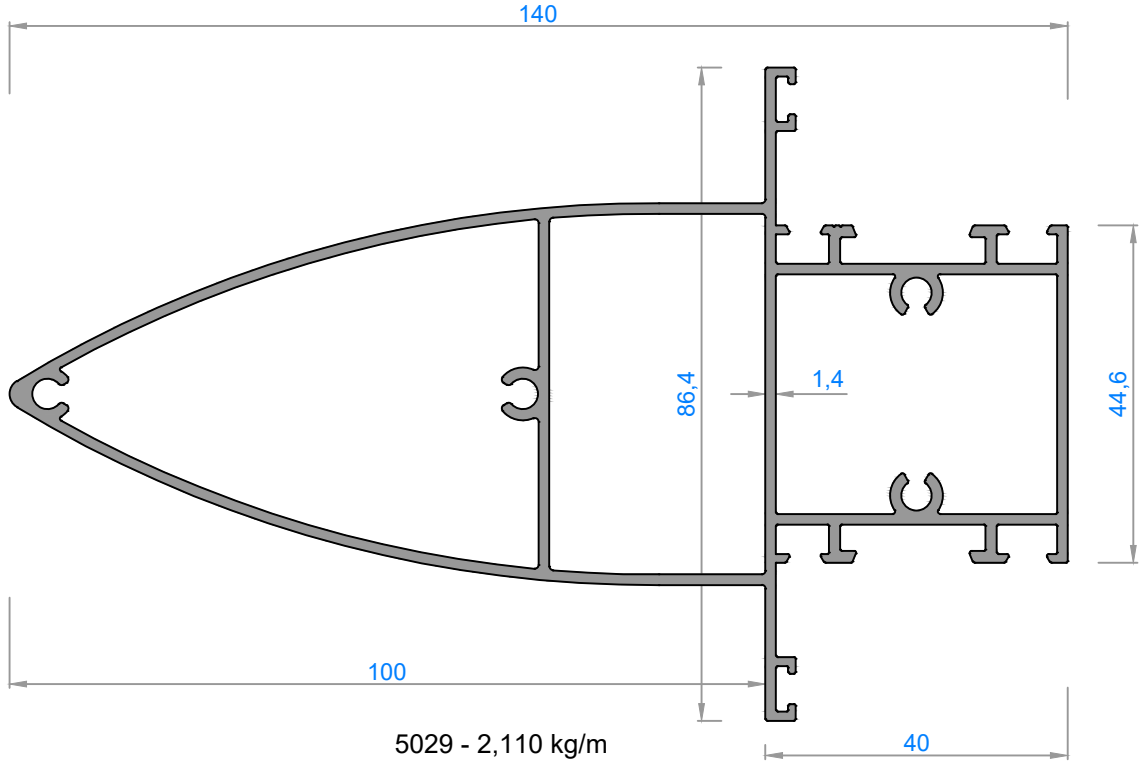

5030 - 1,110 kg/m

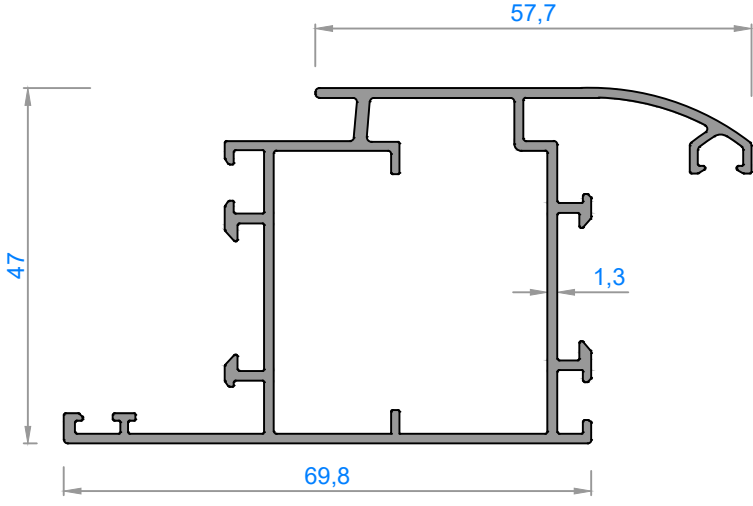

5388 - 1,064 kg/m

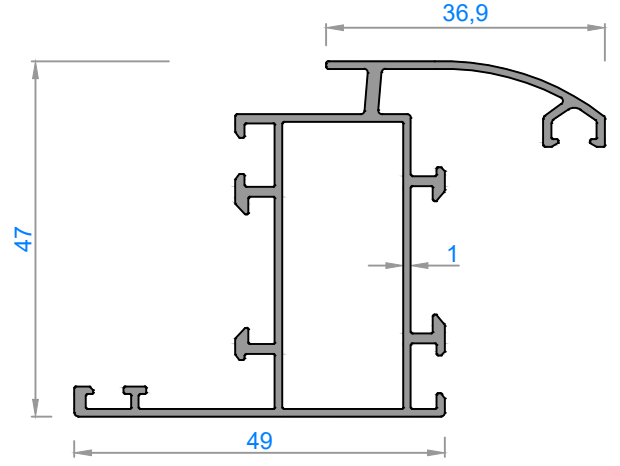

5386 - 0,730 kg/m

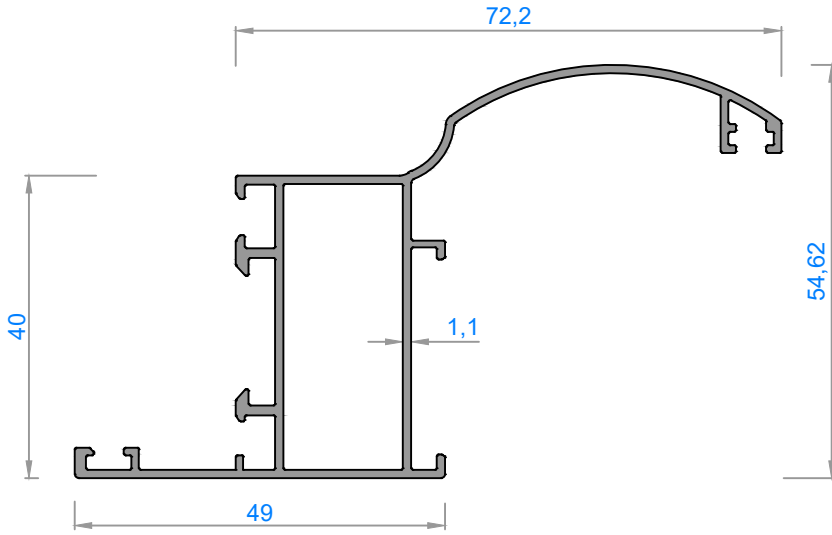

5387 - 0,770 kg/m

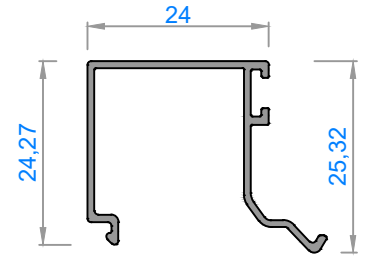

5385 - 0,220 kg/m

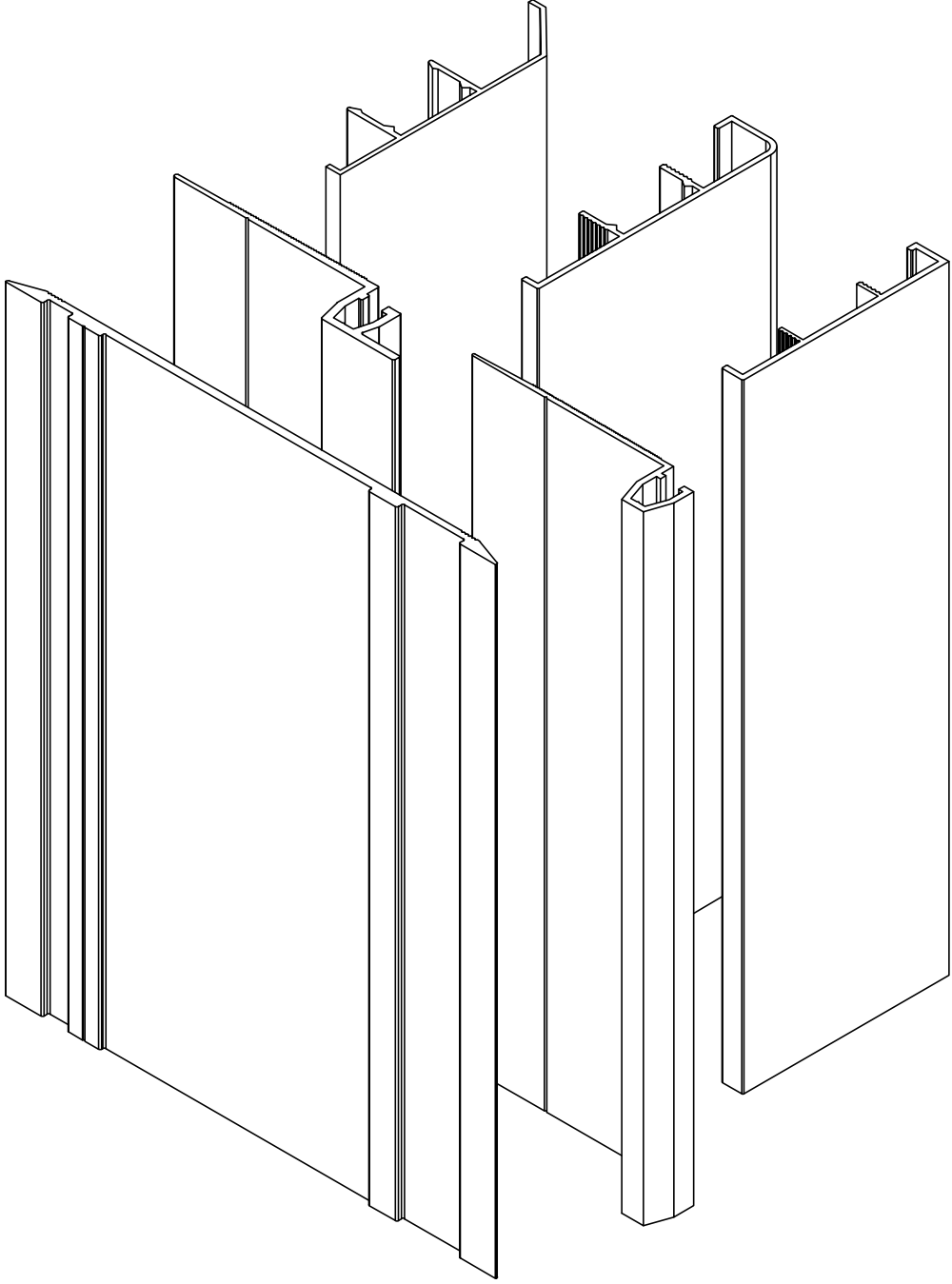

SÜPÜRGELİK PROFİLLERİ / Florr Profiles

DİLATASYON PROFİLLERİ / Dilatation Profiles

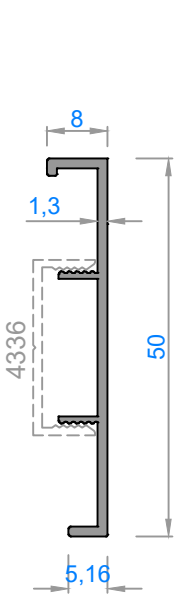

5434 - 0,240 kg/m

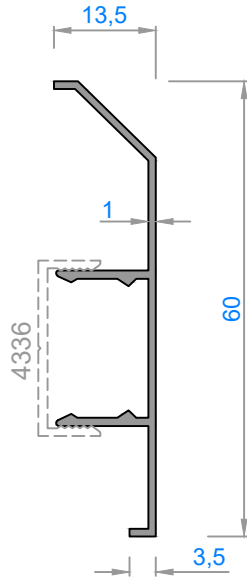

3918 - 0,272 kg/m

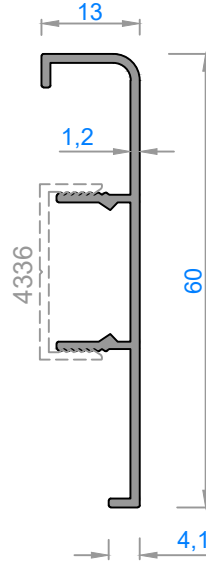

4830 - 0,315 kg/m

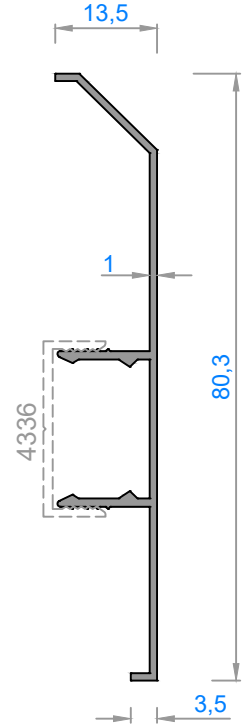

3919 - 0,323 kg/m

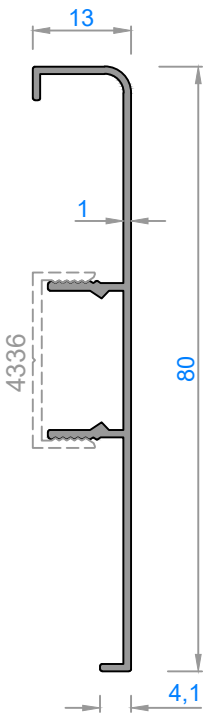

4345 - 0,355 kg/m

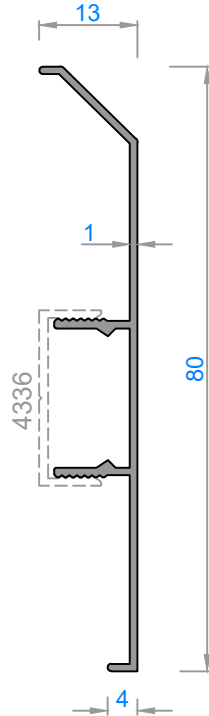

4346 - 0,313 kg/m

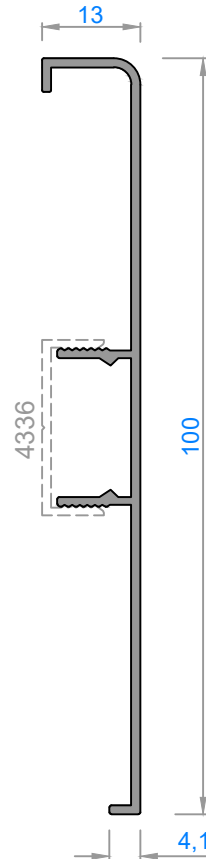

4347 - 0,445 kg/m

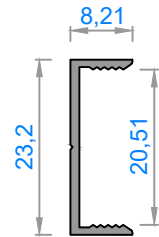

4336 - 0,120 kg/m

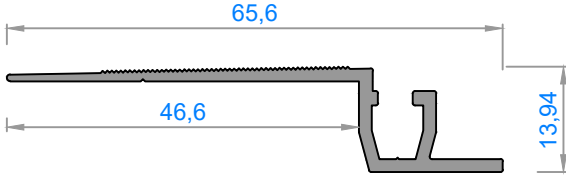

3914 - 0,370 kg/m

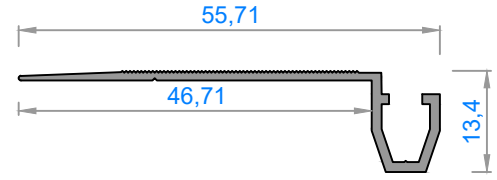

3921 - 0,240 kg/m

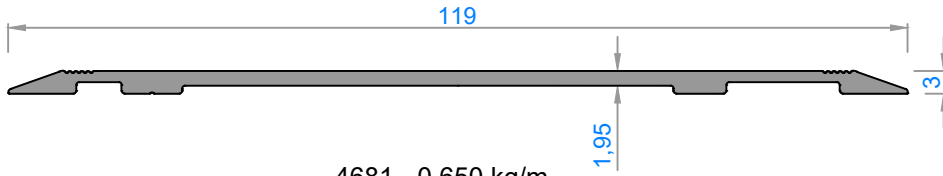

4681 - 0,650 kg/m

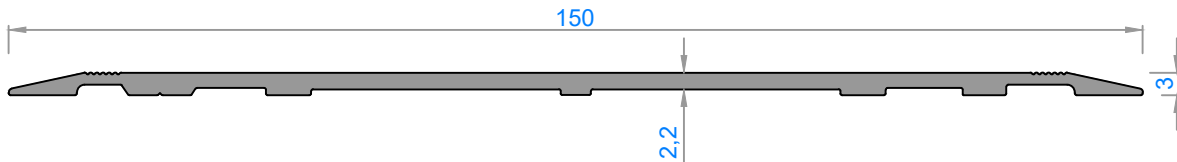

5306 - 0,905 kg/m

OKYANUS[®]

ALÜMİNYUM

Merkez Ofis / Head Office

Akçaburgaz Mah. 1575 Sok. Alkop San. Sitesi B4 Blok A-2 Esenyurt / İstanbul - TÜRKİYE
T+90 212 886 16 56 F+90 212 886 86 20

Fabrika / Factory

İstiklal Kurtpınar OSB Mah. 23. Sokak No: 4/1 Muratlı / Tekirdağ / TÜRKİYE
T+90 282 373 76 36 F+90 282 373 76 51

www.okyanusalu.com

