

ÇİT SİSTEMLERİ / ALUFENCE SYSTEMS

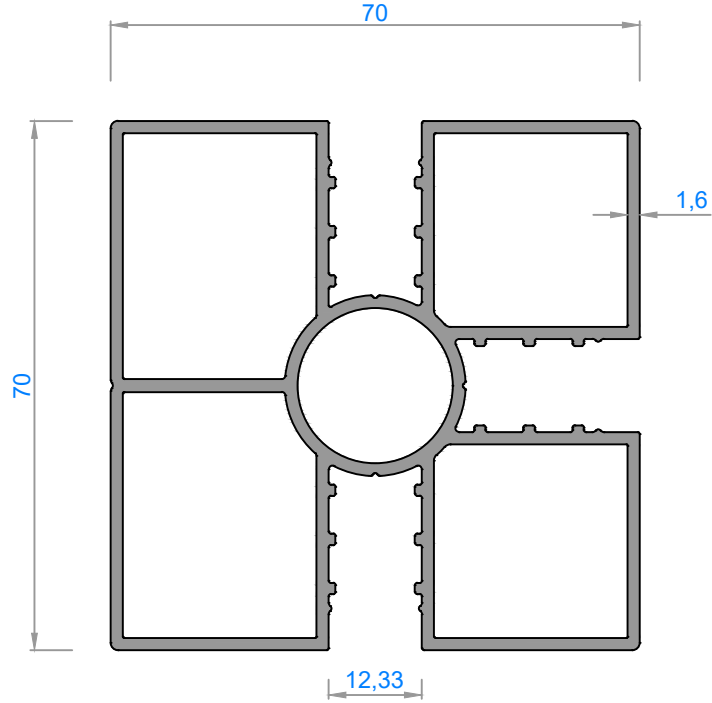

Sistem Kodu : 6182

Ağırlık (kg/mt): 2,136

Statik
Statik Jx (cm⁴): 39,13

Jy (cm⁴): 39,50

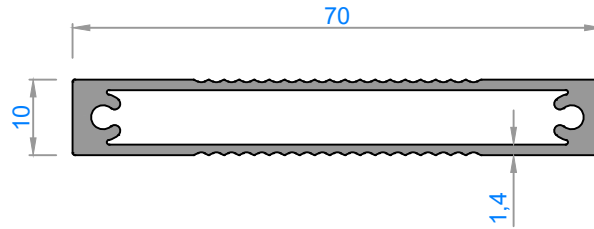

Sistem Kodu : 6183

Ağırlık (kg/mt): 0,658

Statik
Statik Jx (cm⁴): 14,60

Jy (cm⁴): 0,35

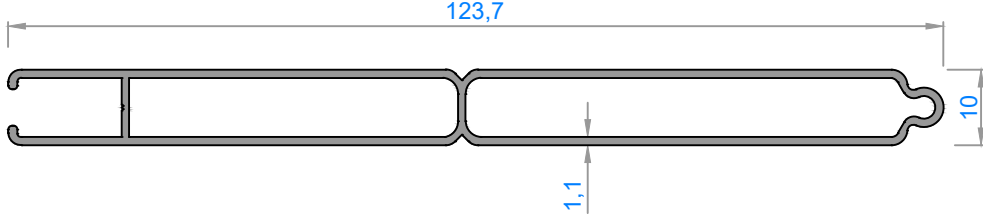

Sistem Kodu : 1324

Ağırlık (kg/mt): 0,800

Statik
Static Jx (cm⁴): 38,50

Jy (cm⁴): 0,53

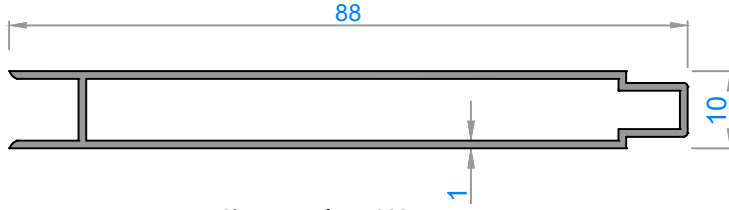

Sistem Kodu : 1083

Ağırlık (kg/mt): 0,520

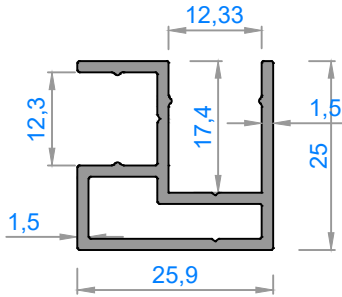

Sistem Kodu : 3814

Ağırlık (kg/mt): 0,450

Statik
Static Jx (cm⁴): 1,07

Jy (cm⁴): 1,23

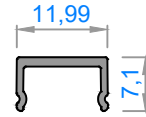

Sistem Kodu : 3560

Ağırlık (kg/mt): 0,067

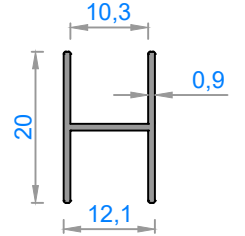

Sistem Kodu : 6184

Ağırlık (kg/mt): 0,123

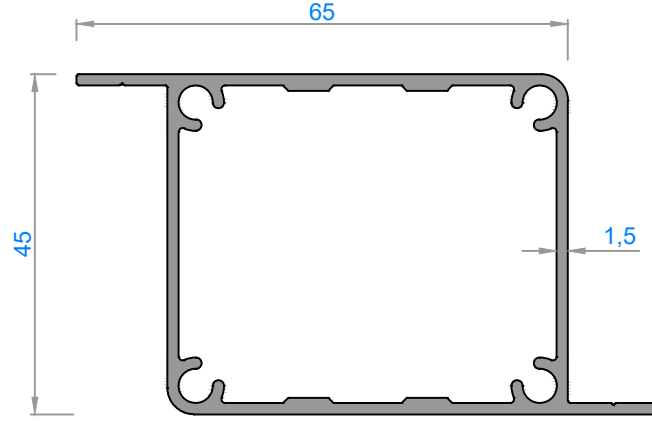

Sistem Kodu : 5868

Ağırlık (kg/mt): 1,021

Statik J_x (cm⁴): 11,72

J_y (cm⁴): 19,15

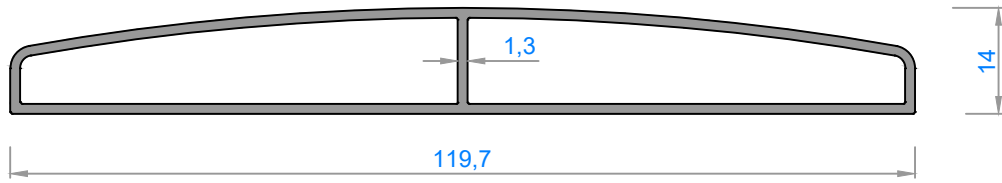

Sistem Kodu : 5867

Ağırlık (kg/mt): 0,924

Statik J_x (cm⁴): 42,22

J_y (cm⁴): 1,00

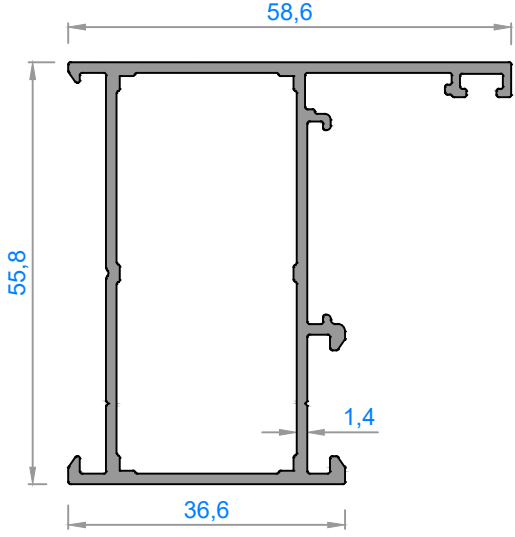

Sistem Kodu : 6175

Ağırlık (kg/mt): 0,876

Statik J_x (cm⁴): 15,83

Statik J_y (cm⁴): 6,70

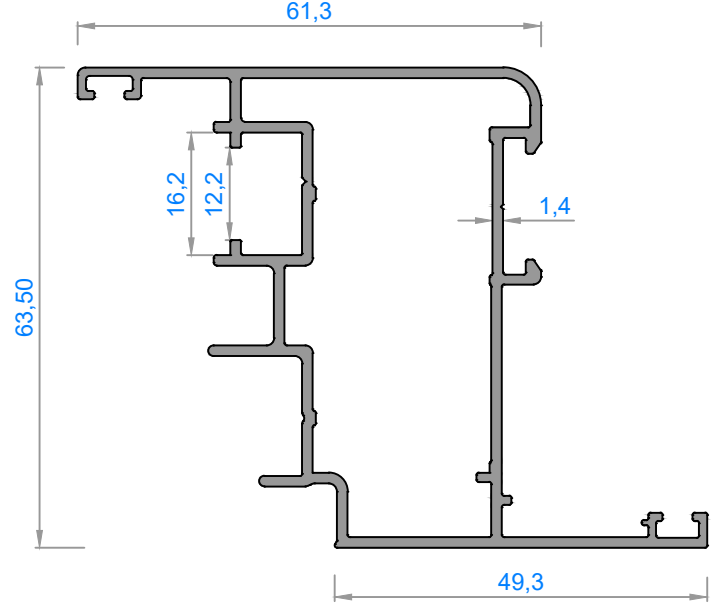

Sistem Kodu : 6176

Ağırlık (kg/mt): 1,175

Statik J_x (cm⁴): 29,03

Statik J_y (cm⁴): 9,83

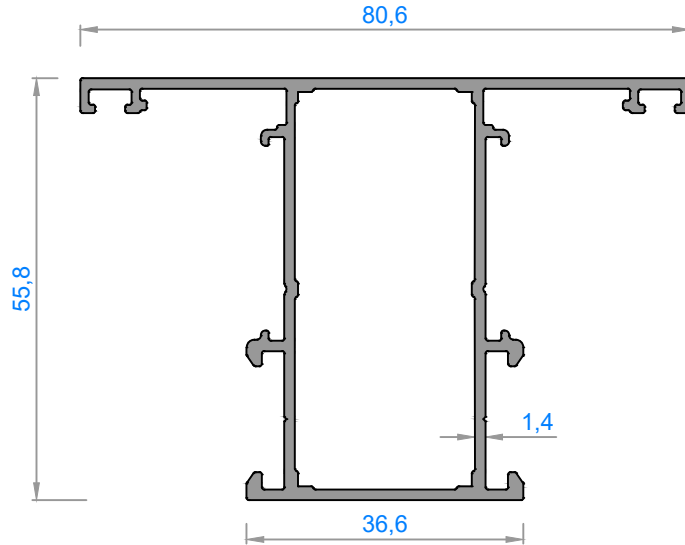

Sistem Kodu : 6177

Ağırlık (kg/mt): 1,027

Statik J_x (cm⁴): 17,24

Statik J_y (cm⁴): 12,88

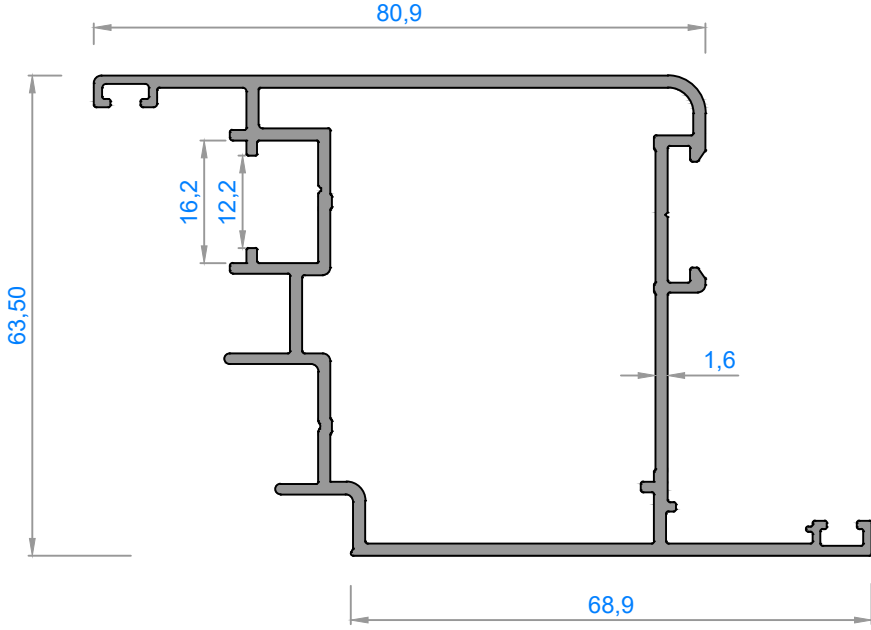

Sistem Kodu : 6178

Ağırlık (kg/mt): 1,463

Statik J_x (cm⁴): 21,56

Statik J_y (cm⁴): 46,68

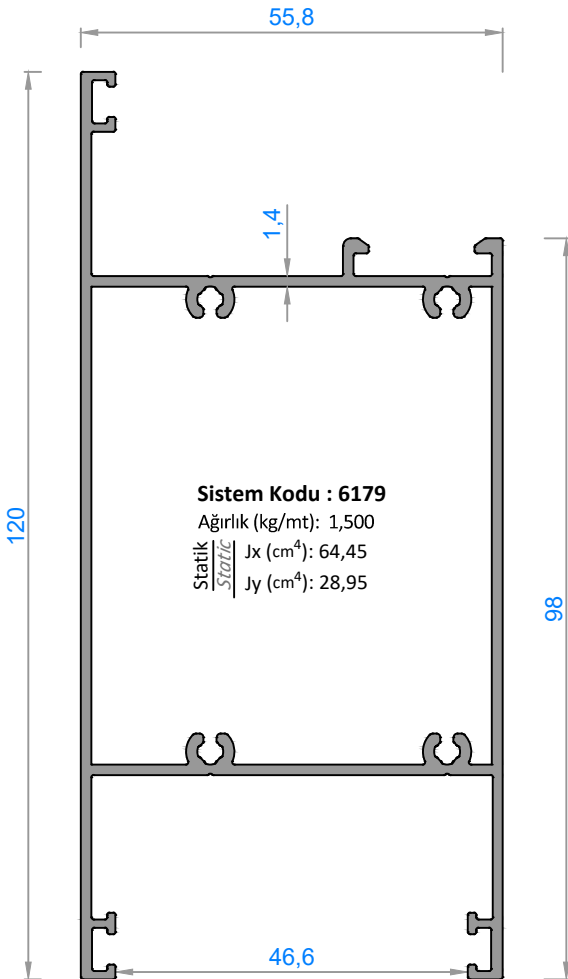

Sistem Kodu : 6179

Ağırlık (kg/mt): 1,500

Statik J_x (cm⁴): 64,45

Statik J_y (cm⁴): 28,95

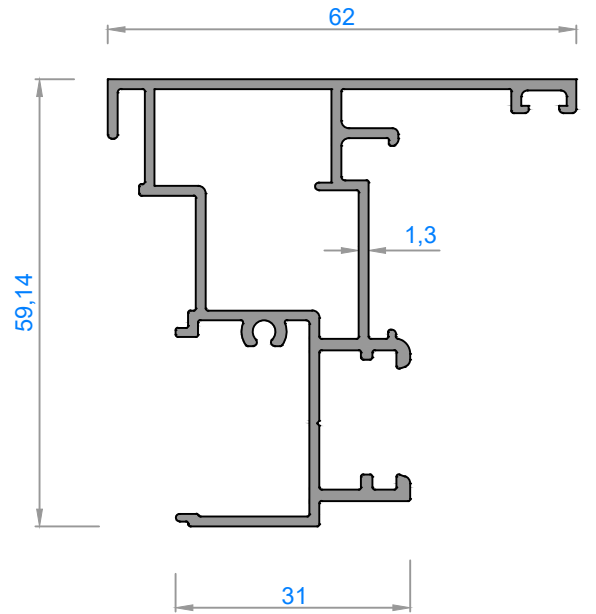

Sistem Kodu : 6180

Ağırlık (kg/mt): 0,962

Statik J_x (cm⁴): 14,25

Statik J_y (cm⁴): 7,12

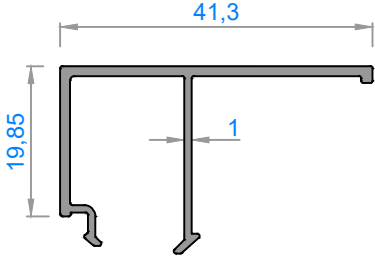

Sistem Kodu : 6155
Ağırlık (kg/mt): 0,304

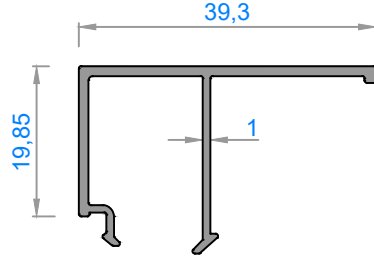

Sistem Kodu : 6156
Ağırlık (kg/mt): 0,303

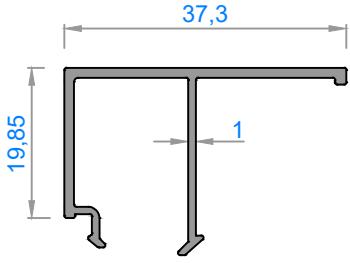

Sistem Kodu : 6157
Ağırlık (kg/mt): 0,296

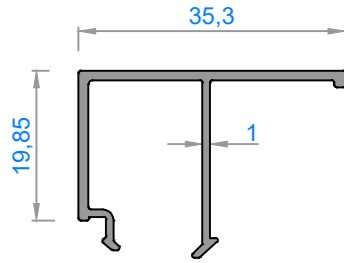

Sistem Kodu : 6158
Ağırlık (kg/mt): 0,283

CAM ÇİTASI GLAZING BEAD	İÇ CAM FİTİLİ GLAZING GASKET	CAM KALINLIĞI GLASS THICKNESS	DIŞ CAM FİTİLİ GLAZING GASKET
6155	FTL01	4mm	FTL02
6156	FTL01	6mm	FTL02
6157	FTL01	8mm	FTL02
6158	FTL01	10mm	FTL02
6159	FTL01	12mm	FTL02
6160	FTL01	14mm	FTL02
6161	FTL01	16mm	FTL02
6162	FTL01	18mm	FTL02
6163	FTL01	20mm	FTL02
6164	FTL01	22mm	FTL02
6165	FTL01	24mm	FTL02
6166	FTL01	26mm	FTL02
6167	FTL01	28mm	FTL02
6168	FTL01	30mm	FTL02

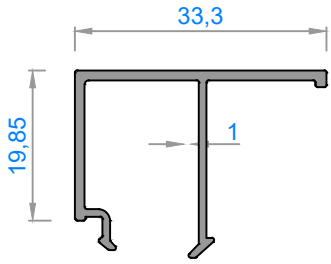

Sistem Kodu : 6159
Ağırlık (kg/mt): 0,282

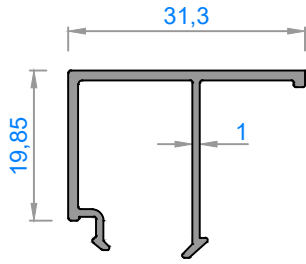

Sistem Kodu : 6160
Ağırlık (kg/mt): 0,275

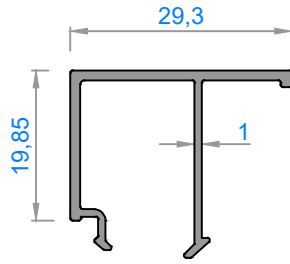

Sistem Kodu : 6161
Ağırlık (kg/mt): 0,268

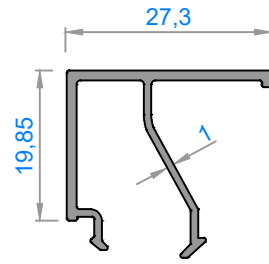

Sistem Kodu : 6162
Ağırlık (kg/mt): 0,264

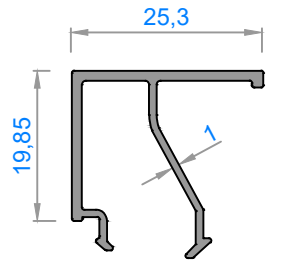

Sistem Kodu : 6163
Ağırlık (kg/mt): 0,251

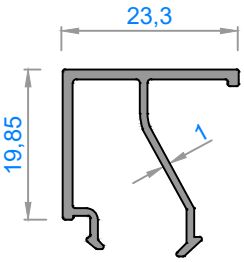

Sistem Kodu : 6164
Ağırlık (kg/mt): 0,250

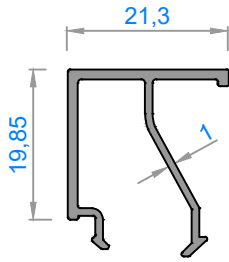

Sistem Kodu : 6165
Ağırlık (kg/mt): 0,237

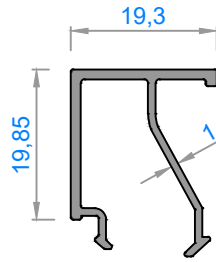

Sistem Kodu : 6166
Ağırlık (kg/mt): 0,236

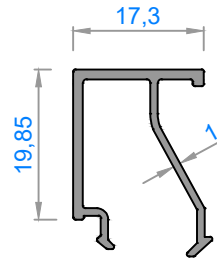



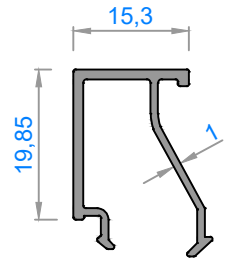

Sistem Kodu : 6167
Ağırlık (kg/mt): 0,229

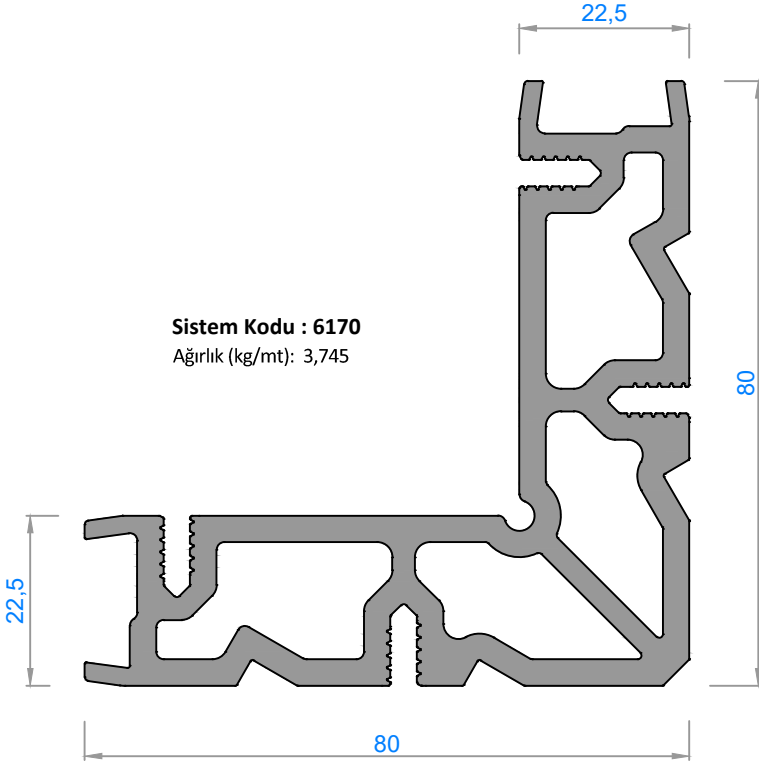

Sistem Kodu : 6168
Ağırlık (kg/mt): 0,222



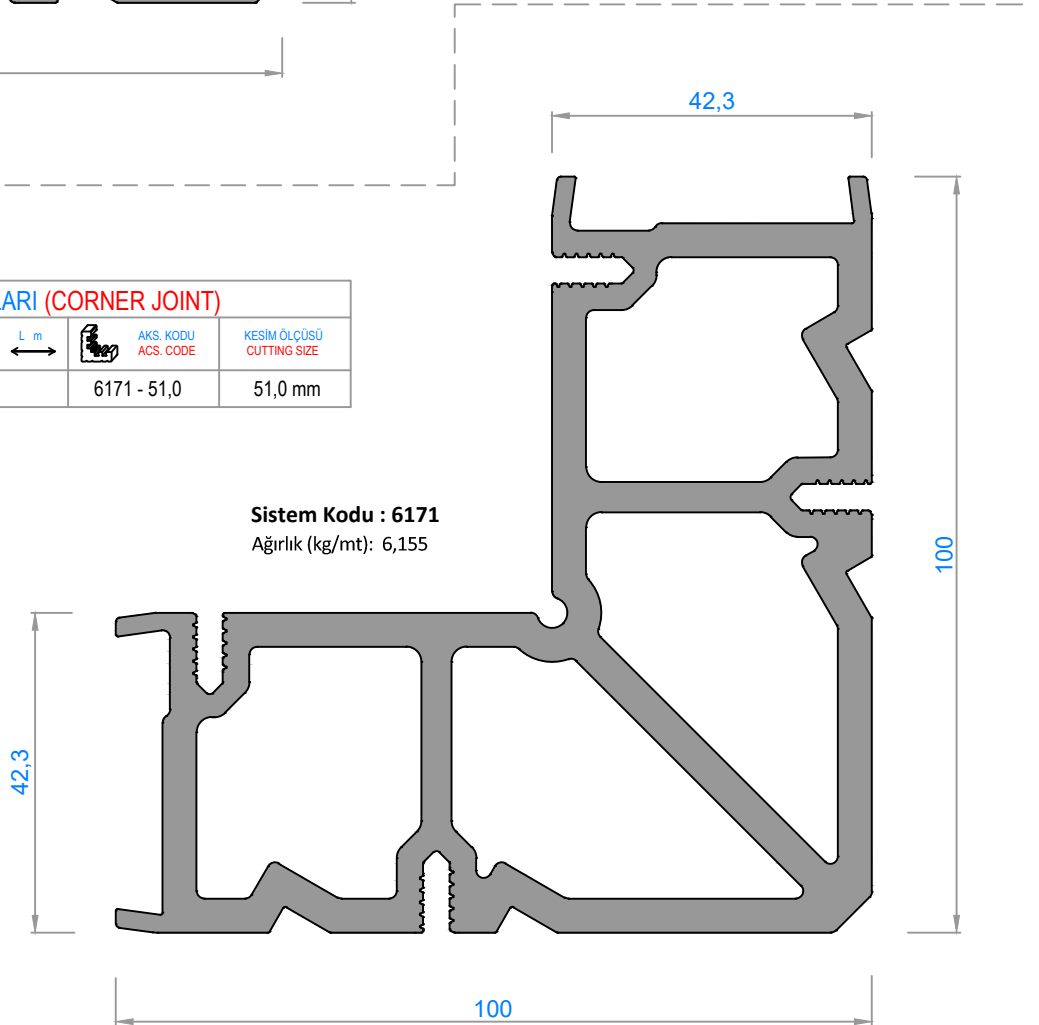

KÖŞE TAKOZLARI (CORNER JOINT)			
Nr	 L m	 AKS. KODU ACS. CODE	KESİM ÖLÇÜSÜ CUTTING SIZE
6175	6170	6170 - 51,0	51,0 mm
6176	6170	6170 - 51,0	51,0 mm
6177	6170	6170 - 51,0	51,0 mm
6180	6170	6170 - 11,9	11,9 mm

KÖŞE TAKOZLARI (CORNER JOINT)			
Nr	 L m	 AKS. KODU ACS. CODE	KESİM ÖLÇÜSÜ CUTTING SIZE
6178	6171	6171 - 51,0	51,0 mm



Sistem Kodu : 6172
Ağırlık (kg/mt): 0,315

ORTA KAYIT BAĞLANTI (MULLION CONNECTION PIECE)			
Nr	 L m	 AKS. KODU ACS. CODE	KESİM ÖLÇÜSÜ CUTTING SIZE
6177	6172	6172 - 22,5	22,5 mm
	6173	6173 - 22,5	22,5 mm

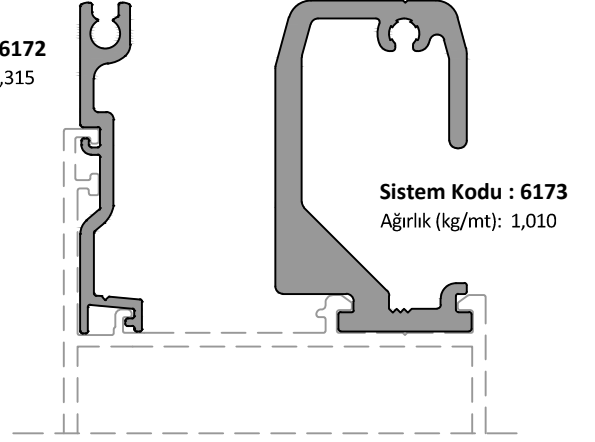

FLT01
EPDM FİTİL



FLT02
EPDM FİTİL



FLT03
EPDM FİTİL



FLT04
EPDM FİTİL

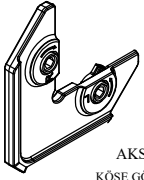

AKS01
KÖŞE GÖNYESİ
CORNER ALIGNMENT

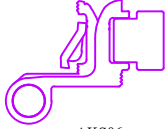

AKS06
PVC KANALLI MENTEŞE
PVC CHANNEL HINGE



AKS08
AKUSTİK KOL
ACOUSTIC HANDLE

AKS07

İSPANYOLET
MEKANİZMASI
MULTI POINT
LOCKING

ÖLÇÜLER
400-600/15
600-800/15
800-1000/15
1000-1200/15
1200-1400/15
1400-1600/15
1600-1800/15
1800-2000/15
2000-2600/15

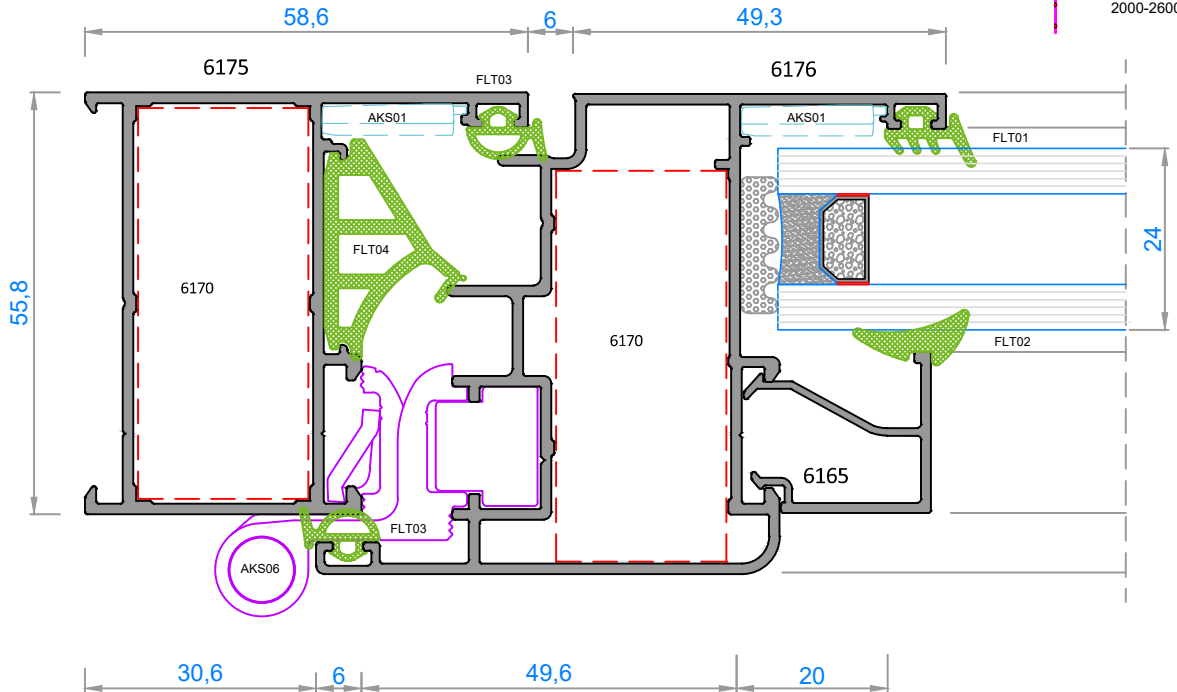

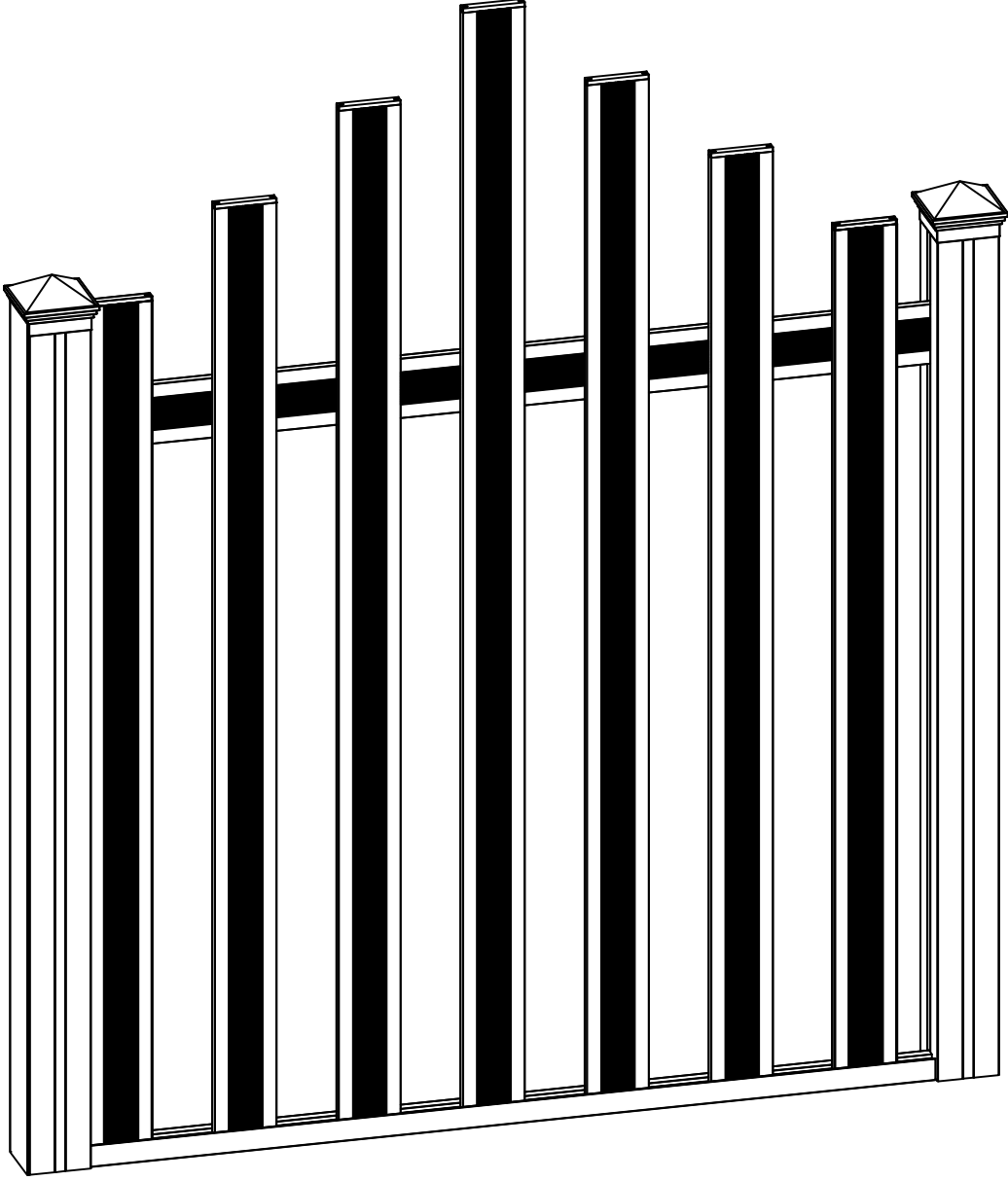

BAHÇE ÇİT SİSTEMLERİ / GARDEN FENCE SYSTEMS

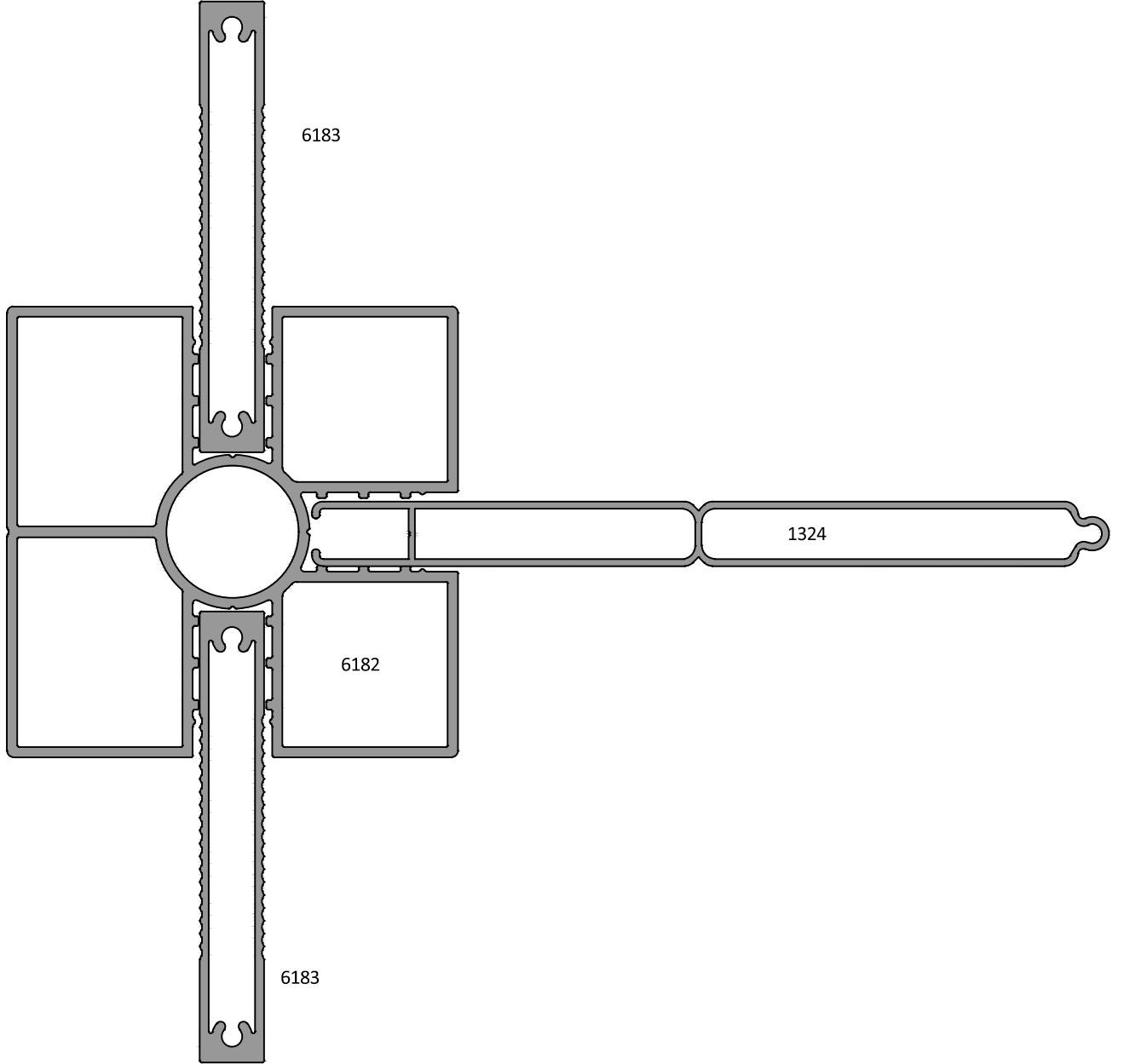

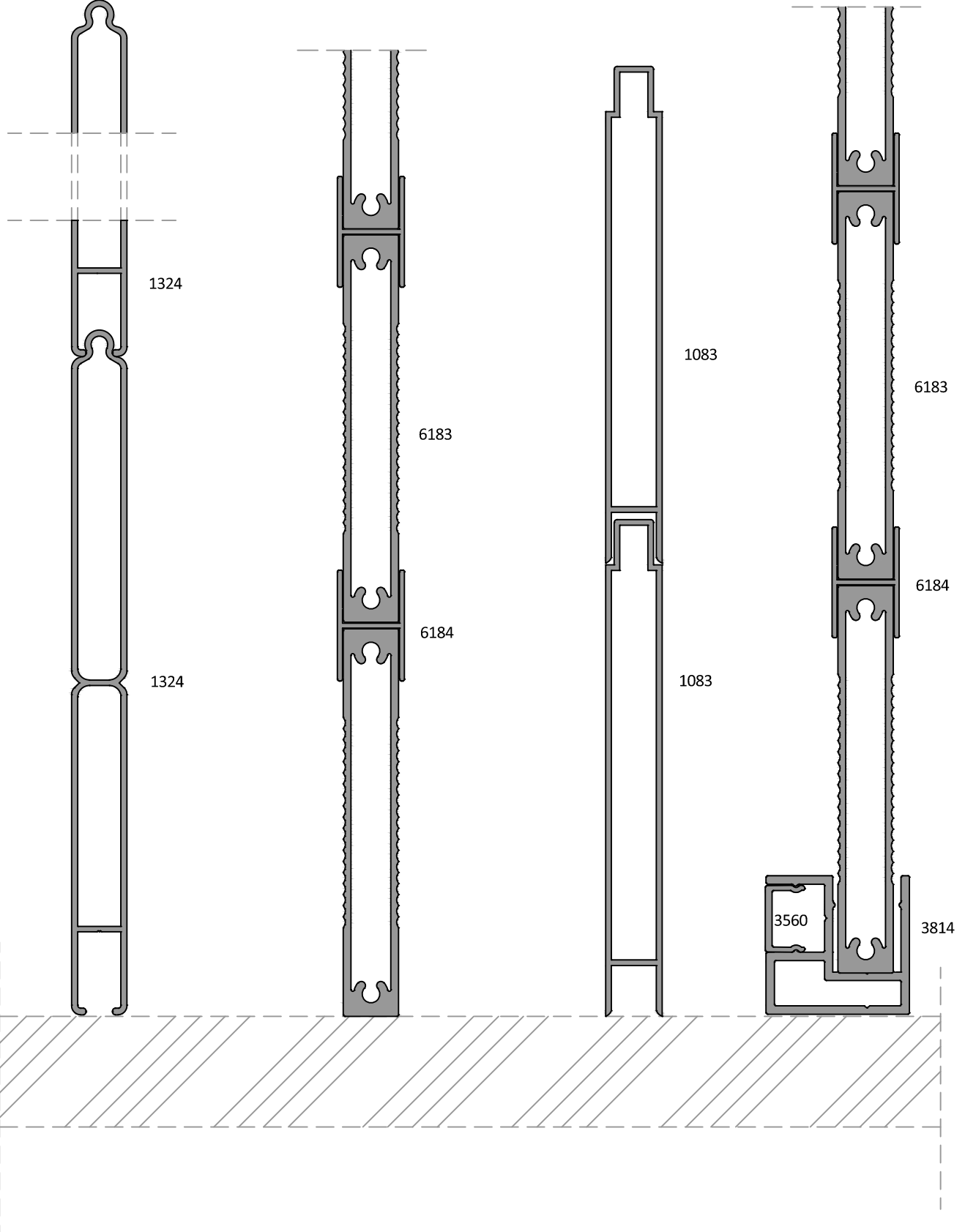

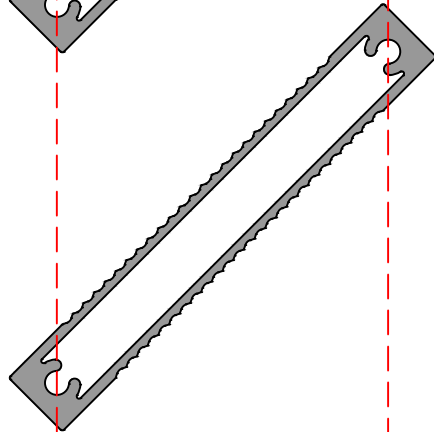
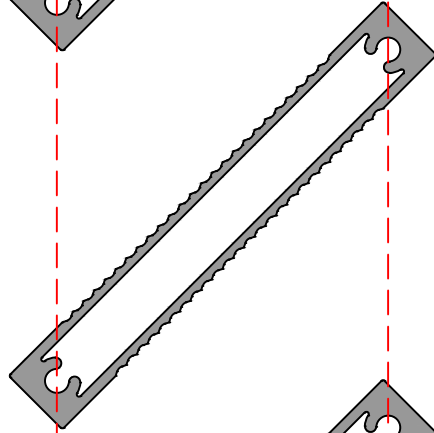
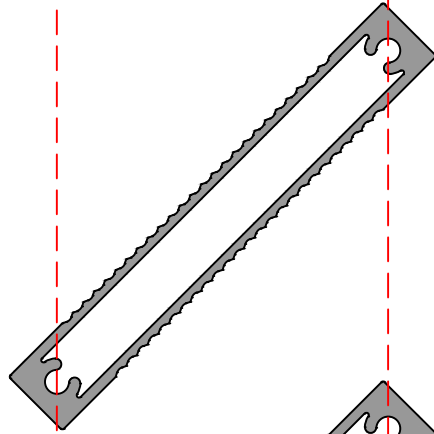
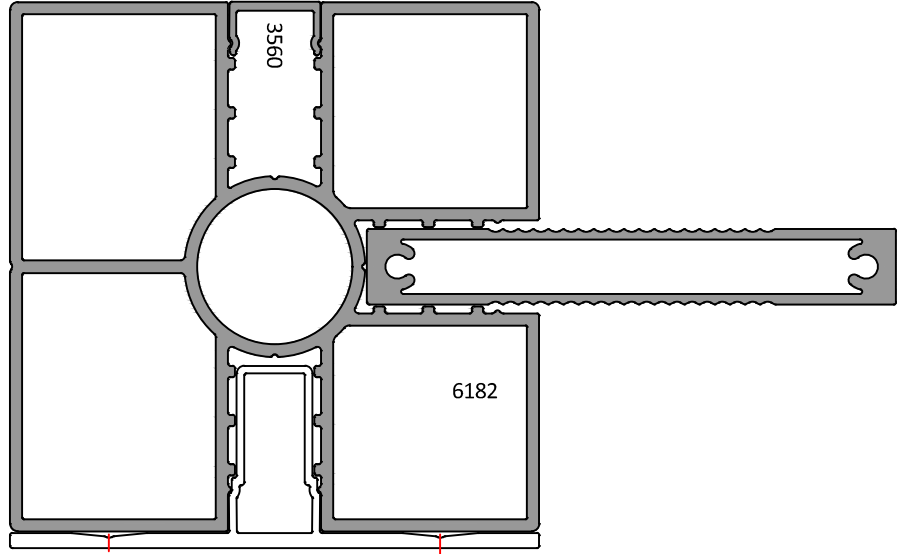

5867

5868

5867

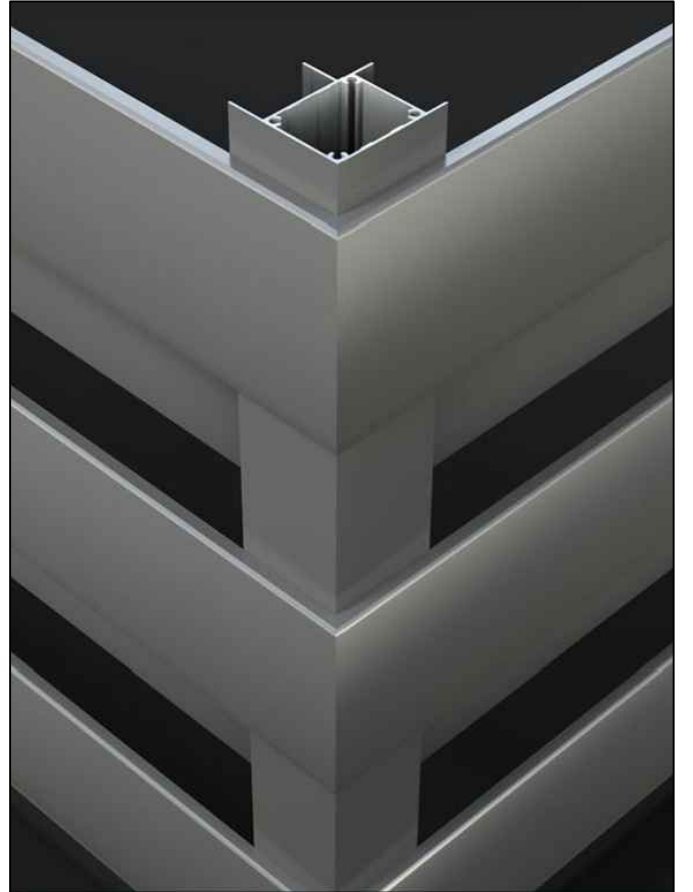

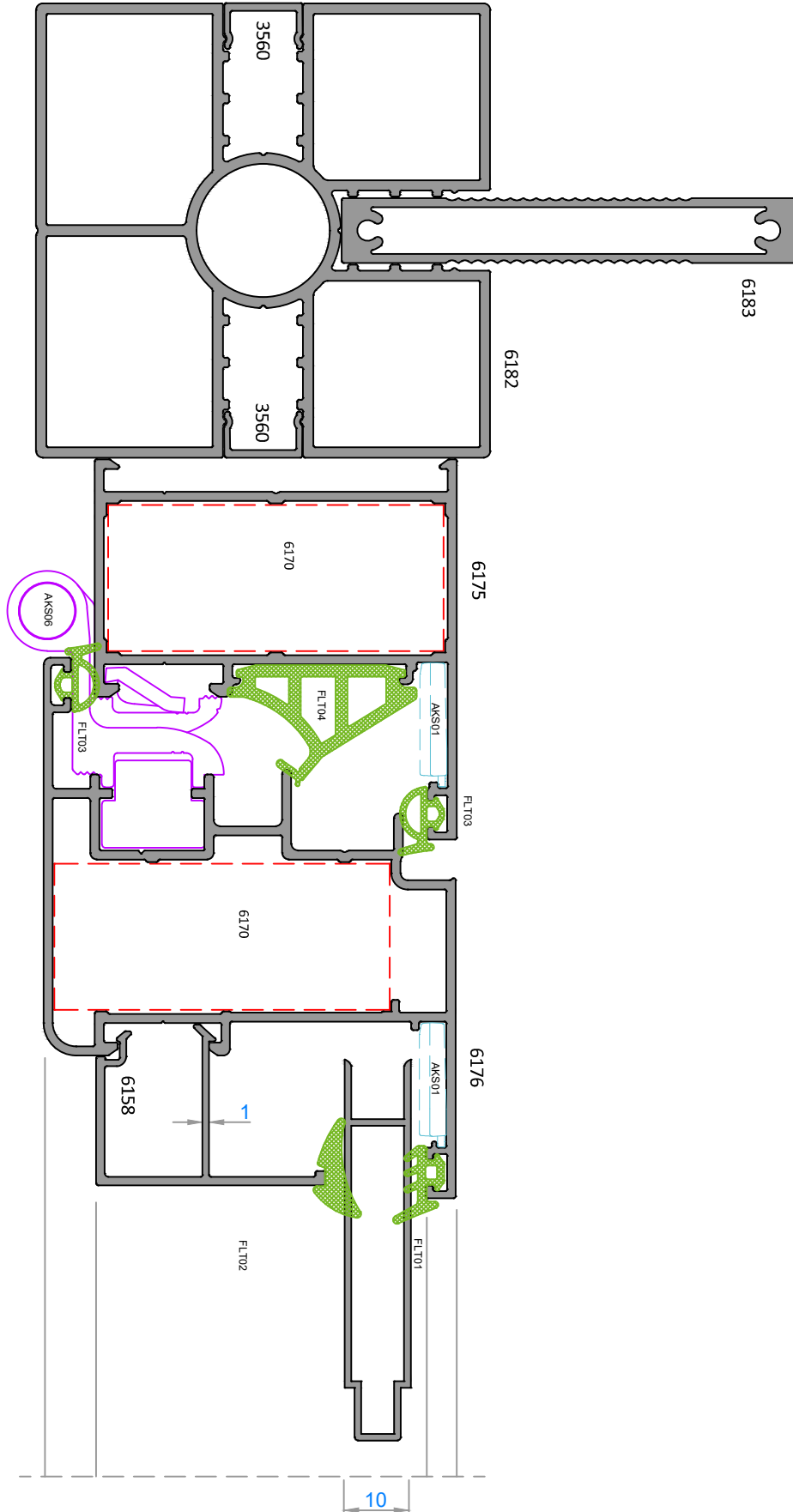

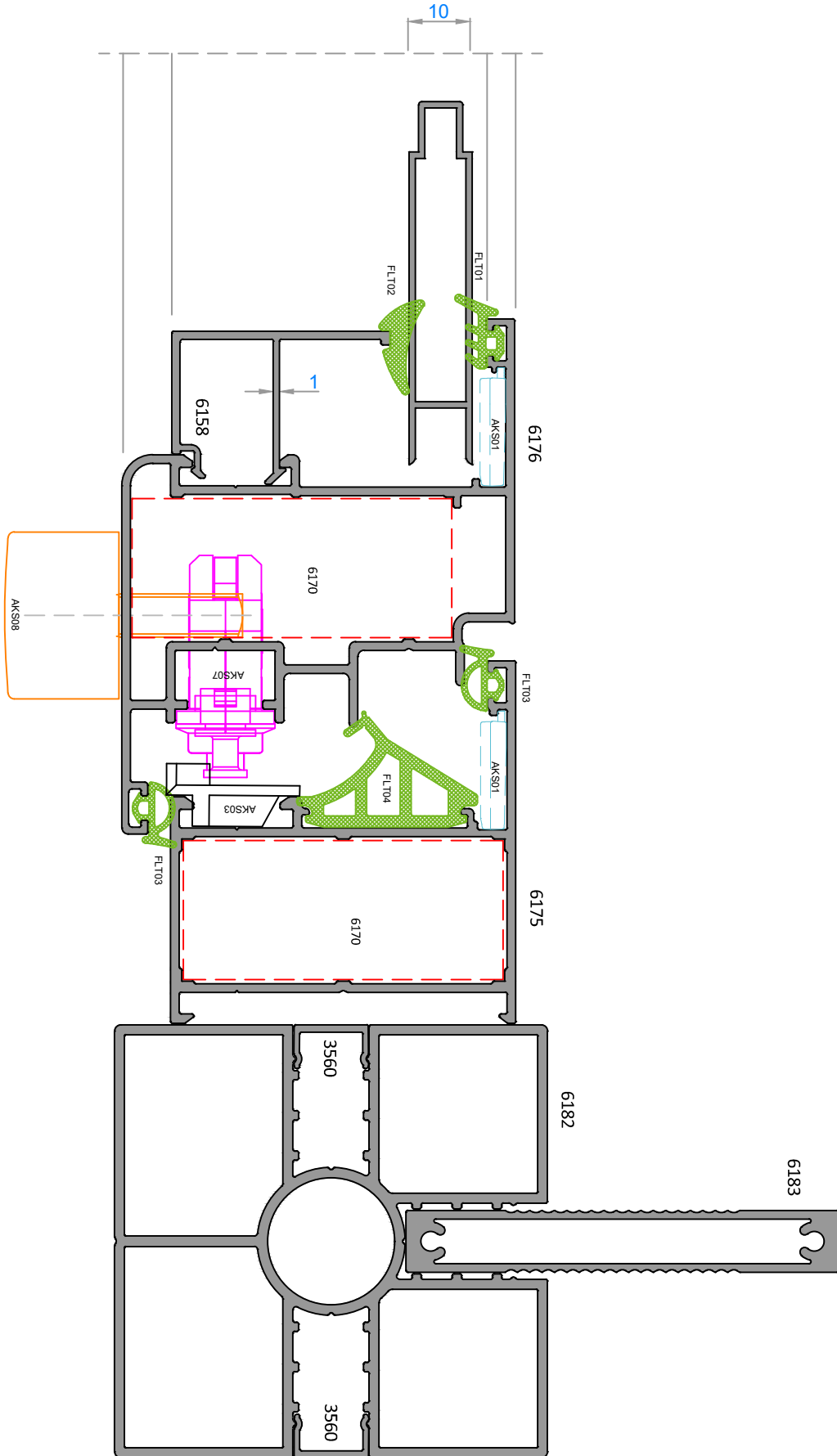

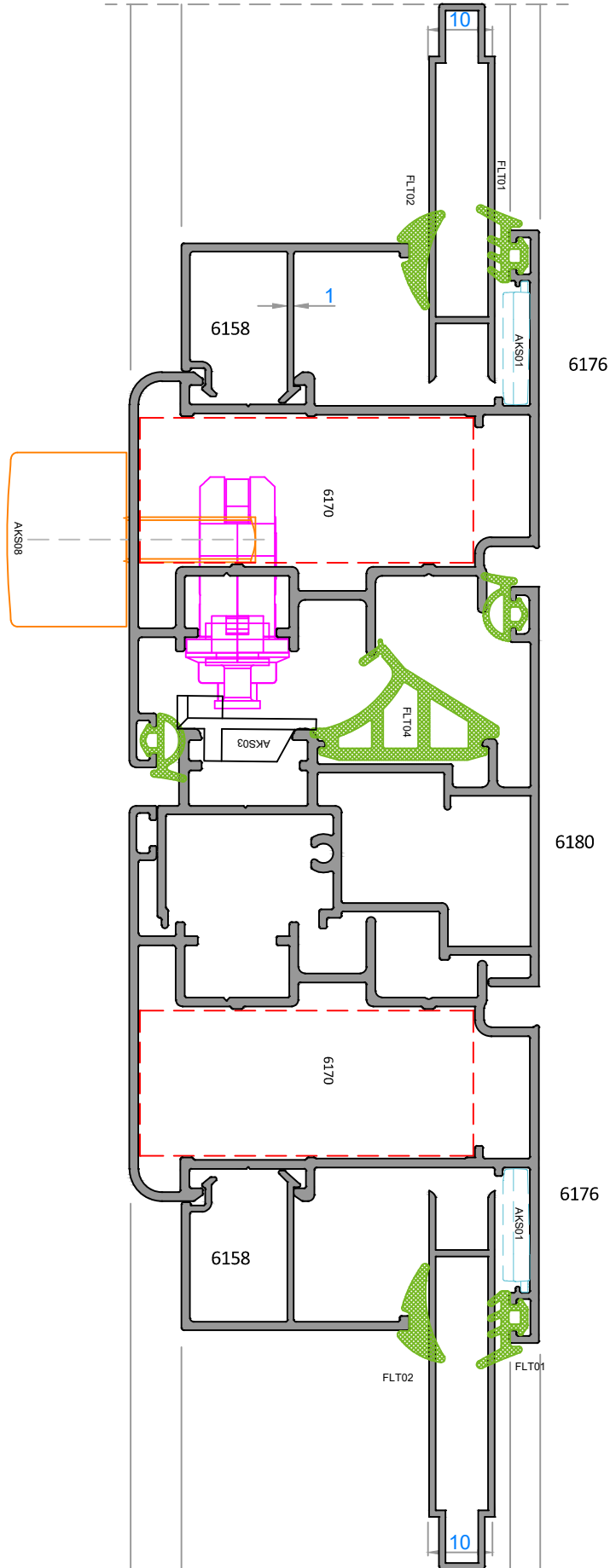

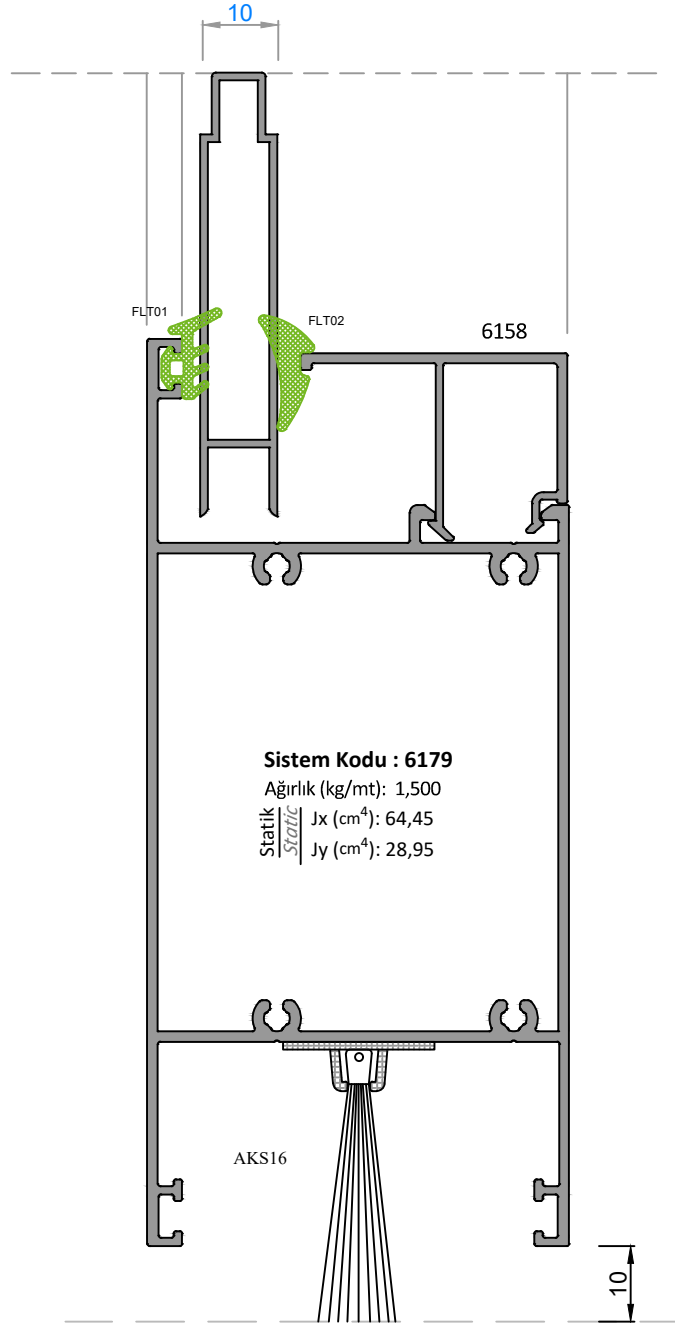

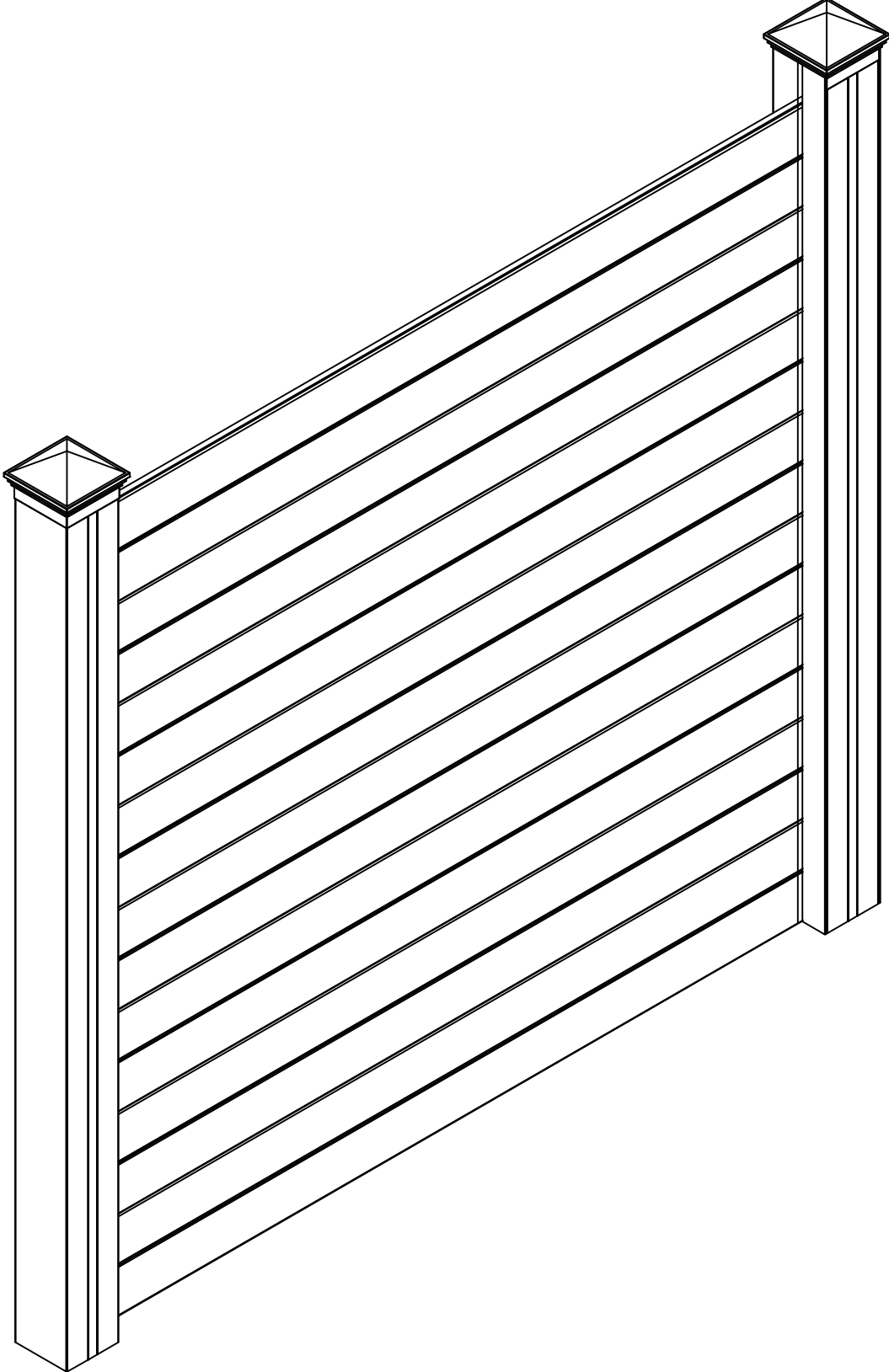

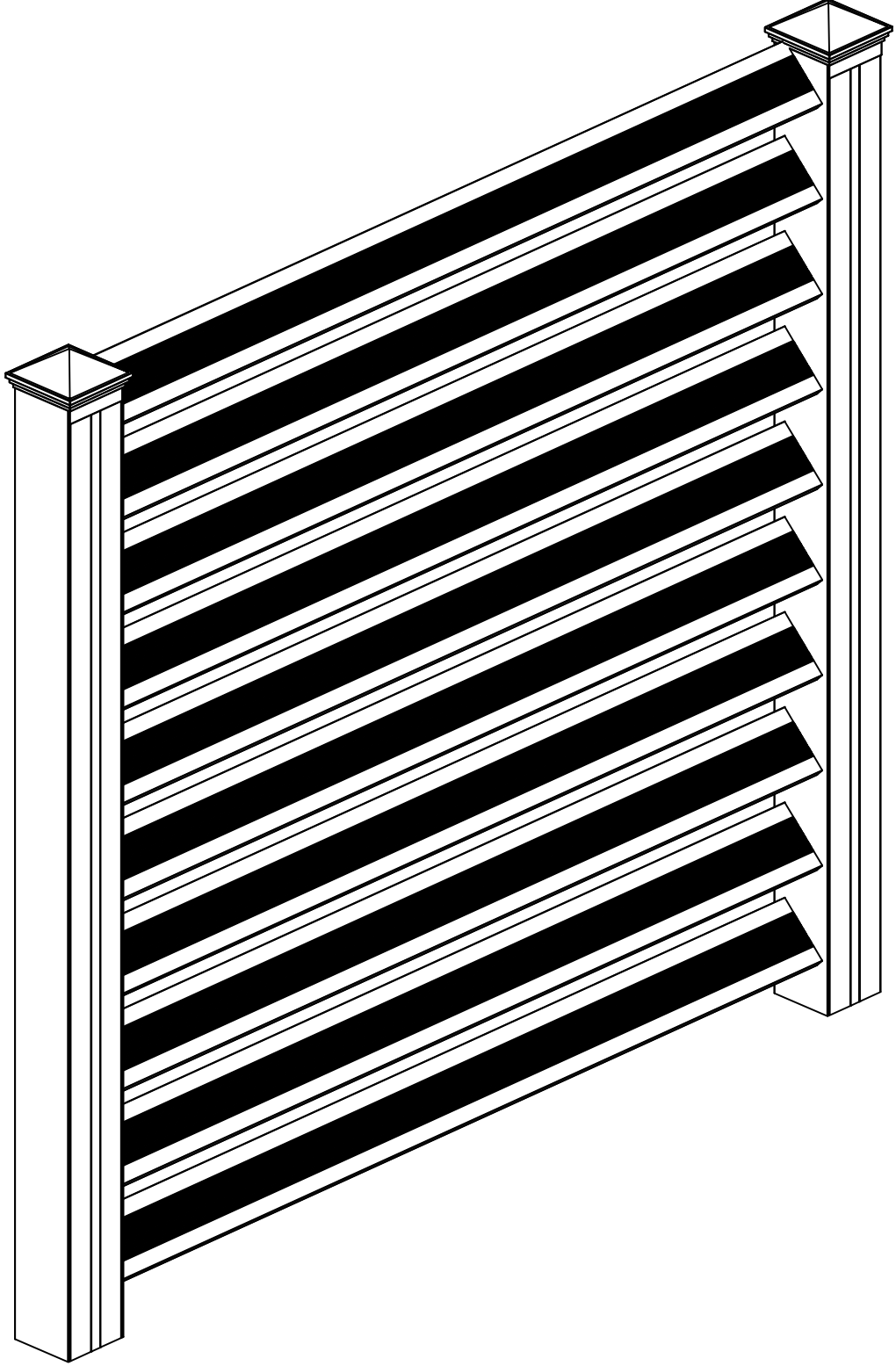

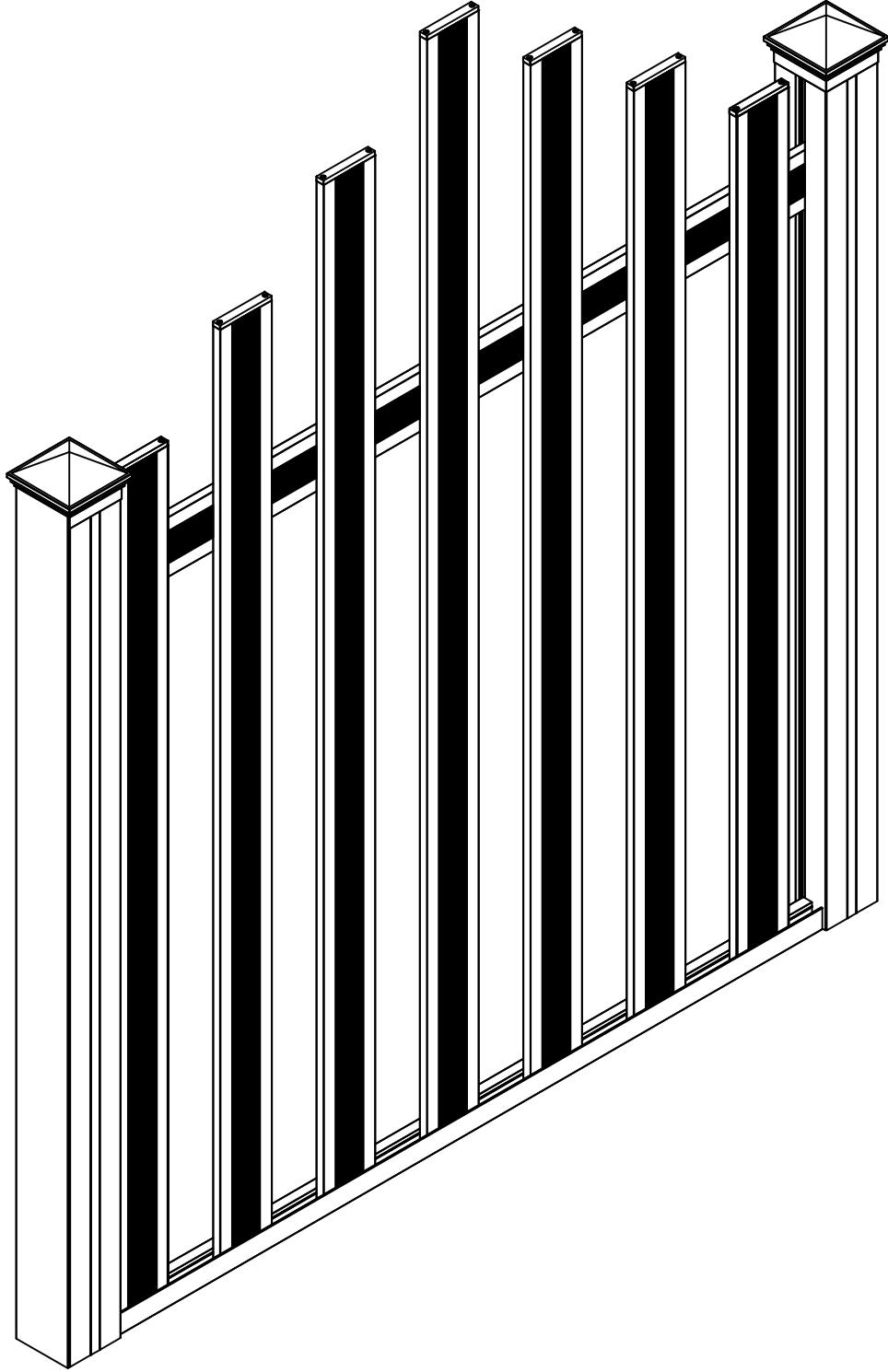

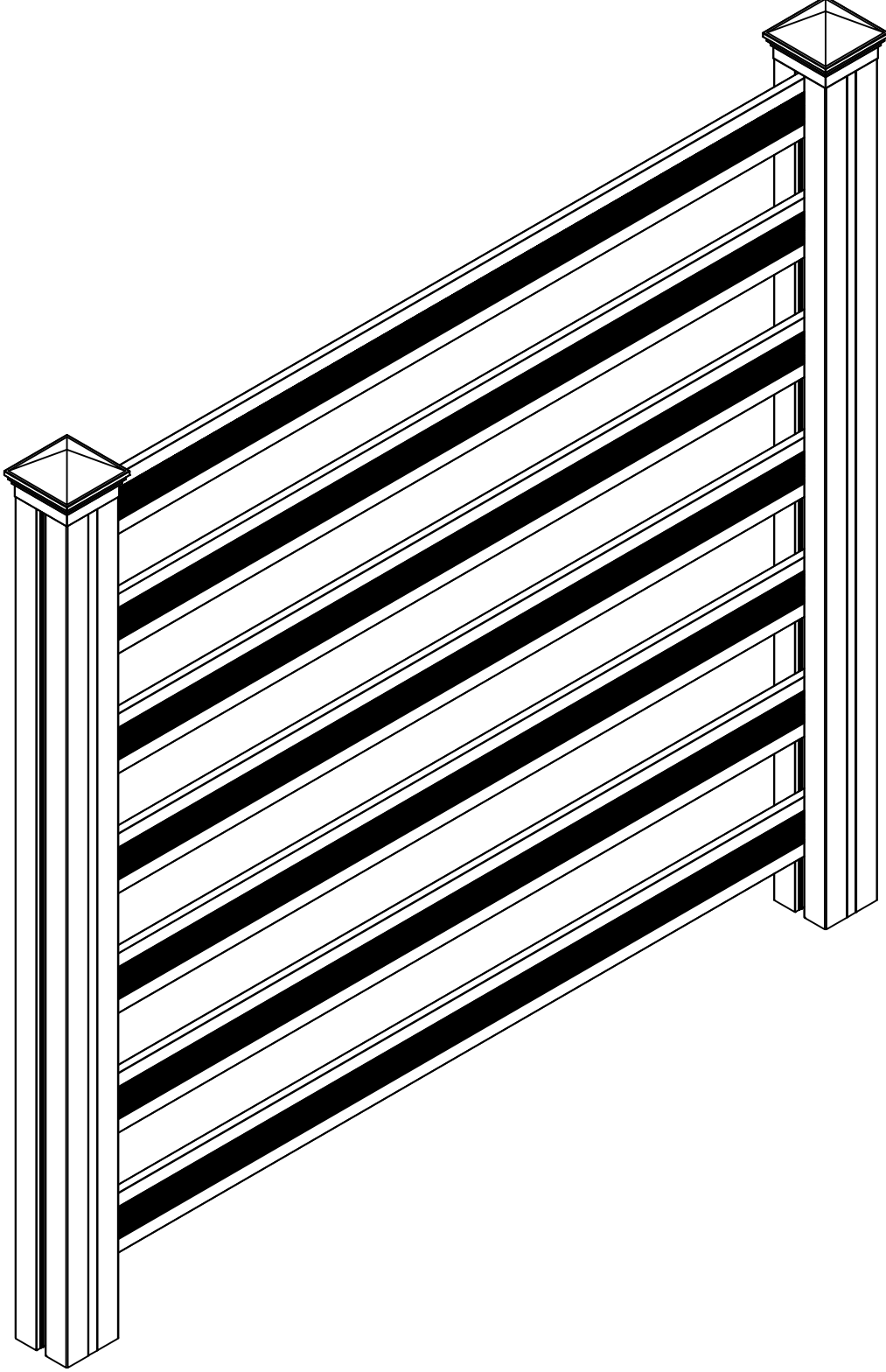

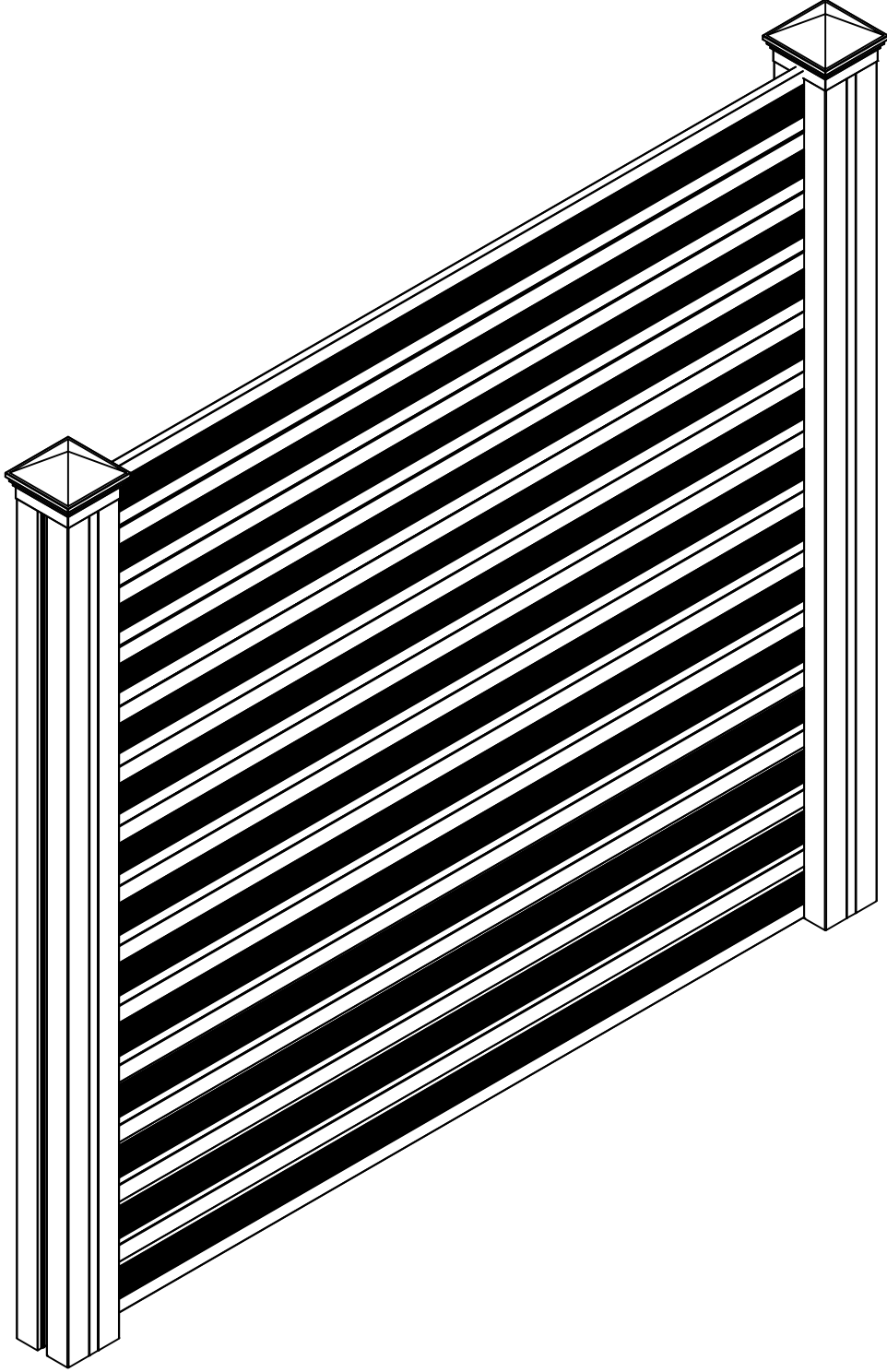

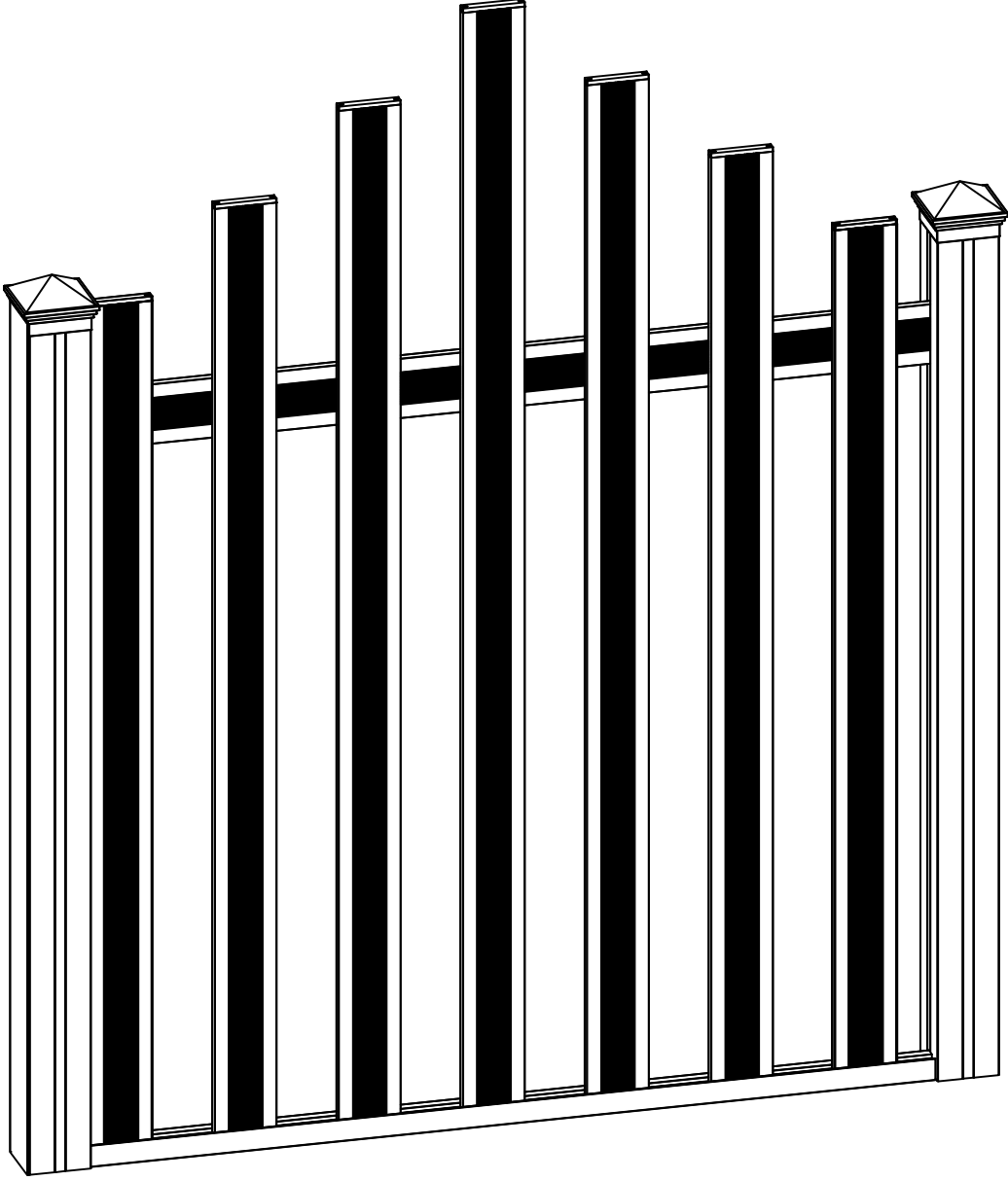

KURULUM VE ÜRETİM ŞEMALARI / INSTALLATION AND PRODUCTION SCHEME

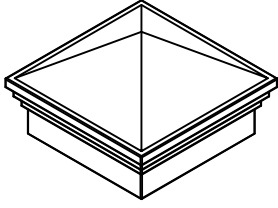

ÇP-3

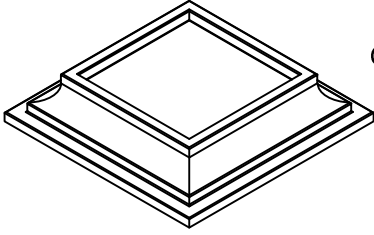

ÇP-4

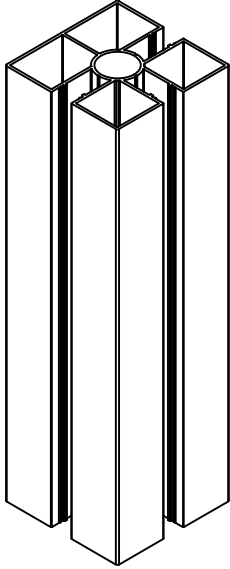

ÇP-5

