

Sürme Sistem
Sliding System

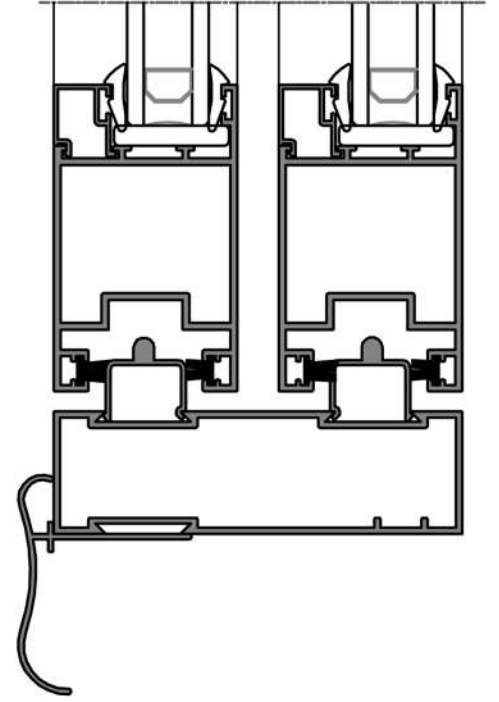

TS45

Sürme Sistem
Sliding System



TEKNİK ÖZELLİKLER / TECHNICAL PROPERTIES



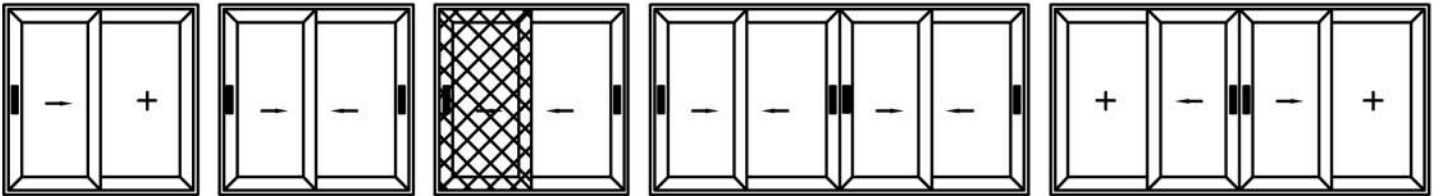

KASA DERİNLİĞİ / FRAME DEPTH	100 mm
KANAT DERİNLİĞİ / SASH DEPTH	45 mm
ET KALINLIĞI / WALL THICKNESS	1,5 – 1,7 mm
MIN/MAX CAM KALINLIĞI / MIN/MAX GLASS THICKNESS	4 - 24 mm
ISI BARIYER / THERMAL BREAK	-

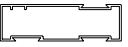
UYGULAMA SEÇENEKLERİ / APPLICATION OPTIONS

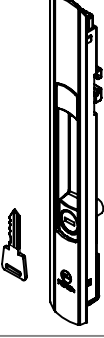

PROF L KES T PROFILE SECTION	PROF L KODU PROFILE CODE	PROF L ADI PROFILE NAME	lx cm	ly cm	A IRLIK (kg/m) WEIGHT
	147	KASA PROF L FRAME PROFILE	-	-	1,207 kg/mt
	150	KASA PROF L FRAME PROFILE	-	-	1,185 kg/mt
	144	KANAT PROF L SASH PROFILE	-	-	1,275 kg/mt
	145	KENET PROF L INTERLOCKING PROFILE	-	-	0,474 kg/mt
	146	ORTA ADAPTÖR PROF L MULLION ADAPTER PROFILE	-	-	0,272 kg/mt
	149	ADAPTÖR PROF L ADAPTER PROFILE	-	-	0,451 kg/mt
	148	RAY PROF L RAIL PROFILE	-	-	0,221 kg/mt
	166	RAY PROF L RAIL PROFILE	-	-	0,196 kg/mt
	12038	RAY PROF L RAIL PROFILE	-	-	0,352 kg/mt
	2278	RAY PROF L RAIL PROFILE	-	-	0,362 kg/mt
	2276	S NEKL K PROF L SCREENING PROFILE	-	-	0,609 kg/mt
	2277	S NEKL K ÇITA PROF L SCREENING BEAD PROFILE	-	-	0,145 kg/mt
	12037	S NEKL K PROF L SCREENING PROFILE	-	-	0,534 kg/mt
	1086	ADAPTÖR PROF L ADAPTER PROFILE	-	-	0,217 kg/mt
	170	ÇITA PROF L BEAD PROFILE	-	-	0,259 kg/mt
	500	KÖ E ÇAVU BA LANTI PROF L CORNER JOINT PROFILE	-	-	1,003 kg/mt
	506	KÖ E ÇAVU BA LANTI PROF L CORNER JOINT PROFILE	-	-	1,075 kg/mt

AKSESUAR ACCESSORY	STOK KODU REFERENCE CODE	AKSESUAR ADI DESCRIPTION	AKSESUAR KODU PRODUCT CODE	PAKET PACK
	03 011230	Ç CAM F T L (EPDM) INNER GLAZING GASKET	TS45- CF30	1 pk / 330 mt
	03 011231	Ç CAM F T L (EPDM) INNER GLAZING GASKET	TS45- CF40	1 pk / 205 mt
	03 010732	Ç CAM F T L (EPDM) INNER GLAZING GASKET	TS45- CF50	1 pk / 175 mt
	03 070103	KAMA F T L 2300 (3MM) SPLINE GASKET 2300 (3MM)	TS45-KMF.03	1 pk / 135 mt
	03 070101	KAMA F T L 2209 (4MM) SPLINE GASKET 2209 (4MM)	TS45-KMF.04	1 pk / 140 mt
	03 070105	KAMA F T L 2210 (5MM) SPLINE GASKET 2210 (5MM)	TS45-KMF.05	1 pk / 200 mt
	03 050711	FIRÇA F T L (6.8 - 8.0 mm) WEATHER STRIP (6.8-8.0 mm)	TS45-FÇ.711	250 mt / pk
	06 140210	CAM TAKOZU (5X28X80 mm) GLAZING WEDGE 5 MM	TS45-CT.210	1 pk / 1000ad
	01 050301	YAYLI TET K KOL (ELOKSALLI) TRIGGER HANDLE WITH SPRING (ANODIZED)	TS45-YTK.301	1 pk / 10ad
	01 050302	YAYLI TET K KOL (BEYAZ) TRIGGER HANDLE WITH SPRING (WHITE)	TS45-YTK.302	1 pk / 10ad
	01 050303	YAYLI TET K KOL (RENKL) TRIGGER HANDLE WITH SPRING (COLORED)	TS45-YTK.303	1 pk / 10ad
	01 050304	K L TL TET K KOL (BEYAZ) LOCKED TRIGGER HANDLE (WHITE)	TS45-KTK.304	1 pk / 10ad
	01 050305	K L TL TET K KOL (ELOKSALLI) LOCKED TRIGGER HANDLE (ANODIZED)	TS45-KTK.305	1 pk / 10ad
	01 071012	SÜRME PAR ZYEN KOL SLIDING HANDLE (PARISIANA)	TS45-PK.12	1 pk / 1ad
	01 050717	ÇEKME HAVUZ KOL (ELOKSALLI) RECESSED PULL HANDLE (ANODIZED)	TS45-CHK.717	1 pk / 50ad
	01 050718	ÇEKME HAVUZ KOL (BEYAZ) RECESSED PULL HANDLE (WHITE)	TS45-CHK.718	1 pk / 50ad
	01 050719	ÇEKME HAVUZ KOL (RENKL) RECESSED PULL HANDLE (COLORED)	TS45-CHK.719	1 pk / 50ad
	01 110107	TEKL RULMAN SARI SINGLE ROLLER (GOLDEN)	TS45-SRG.107	1 pk / 100ad
	01 110112	Ç FTL RULMAN SARI DOUBLE ROLLER (GOLDEN)	TS45-DRG.112	1 pk / 50ad

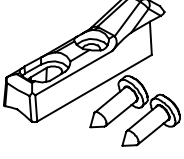
AKSESUAR ACCESSORY	STOK KODU REFERENCE CODE	AKSESUAR ADI DESCRIPTION	AKSESUAR KODU PRODUCT CODE	PAKET PACK
	01 050750	FORZA YAYLI HAVUZ KOL (S YAH) FORZA RECESSED HANDLE AUTOMATIC (BLACK)	TS45-FHK.750	1 pk / 40ad
	01 050751	FORZA YAYLI HAVUZ KOL (BEYAZ) FORZA RECESSED HANDLE AUTOMATIC (WHITE)	TS45-FHK.751	1 pk / 40ad
	01 050752	FORZA YAYLI HAVUZ KOL (NATUREL) FORZA RECESSED HANDLE AUTOMATIC (NATURAL)	TS45-FHK.752	1 pk / 40ad
	01 050753	FORZA YAYLI HAVUZ KOL (ANTRAS T) FORZA RECESSED HANDLE AUTOMATIC (ANTHRACITE)	TS45-FHK.753	1 pk / 40ad
	01 050760	FORZA MANUEL HAVUZ KOL (S YAH) FORZA RECESSED HANDLE MANUEL (BLACK)	TS45-FHK.760	1 pk / 40ad
	01 050761	FORZA MANUEL HAVUZ KOL (BEYAZ) FORZA RECESSED HANDLE MANUEL (WHITE)	TS45-FHK.761	1 pk / 40ad
	01 050762	FORZA MANUEL HAVUZ KOL (NATUREL) FORZA RECESSED HANDLE MANUEL (NATURAL)	TS45-FHK.762	1 pk / 40ad
	01 050763	FORZA MANUEL HAVUZ KOL (ANTRAS T) FORZA RECESSED HANDLE MANUEL (ANTHRACITE)	TS45-FHK.763	1 pk / 40ad
	01 050770	FORZA ANAHTARLI HAVUZ KOL (S YAH) FORZA RECESSED HANDLE LOCK WITH KEY (BLACK)	TS45-FHK.770	1 pk / 40ad
	01 050771	FORZA ANAHTARLI HAVUZ KOL (BEYAZ) FORZA RECESSED HANDLE LOCK WITH KEY (WHITE)	TS45-FHK.771	1 pk / 40ad
	01 050772	FORZA ANAHTARLI HAVUZ KOL (NATUREL) FORZA RECESSED HANDLE LOCK WITH KEY (NATURAL)	TS45-FHK.772	1 pk / 40ad
	01 050773	FORZA ANAHTARLI HAVUZ KOL (ANTRAS T) FORZA RECESSED HANDLE LOCK WITH KEY (ANTHRACITE)	TS45-FHK.773	1 pk / 40ad
	01 050790	FORZA PAS F HAVUZ KOL (S YAH) FORZA RECESSED FINGER PULL HANDLE (BLACK)	TS45-FHK.790	1 pk / 40 ad
	01 050791	FORZA PAS F HAVUZ KOL (BEYAZ) FORZA RECESSED FINGER PULL HANDLE (WHITE)	TS45-FHK.791	1 pk / 40 ad
	01 050792	FORZA PAS F HAVUZ KOL (NATUREL) FORZA RECESSED FINGER PULL HANDLE (NATURAL)	TS45-FHK.792	1 pk / 40 ad
	01 050793	FORZA PAS F HAVUZ KOL (ANTRAS T) FORZA RECESSED FINGER PULL HANDLE (NATURAL)	TS45-FHK.753	1 pk / 40 ad
	01 050781	FORZA K L T D L (ZAMAK) FORZA HOOK (ZAMAK)	TS45-FKD.781	1 pk / 40 ad
	01 050782	FORZA K L T KAR ILI I (ZAMAK) FORZA STRIKER (ZAMAK)	TS45-FKK.782	1 pk / 40 ad

AKSESUAR ACCESSORY	STOK KODU REFERENCE CODE	AKSESUAR ADI DESCRIPTION	AKSESUAR KODU PRODUCT CODE	PAKET PACK
	05 010900	301/B SÜRME K L T (BEYAZ) 301/B SLIDING LOCK (WHITE)	TS45-SKB.900	1 pk / 1 ad
	05 010901	301/G SÜRME K L T (GR) 301/G SLIDING LOCK (GRAY)	TS45-SKG.901	1 pk / 1 ad
	05 010902	301/K SÜRME K L T (KAHVERENG) 301/K SLIDING LOCK (BROWN)	TS45-SKK.902	1 pk / 1 ad
	05 010903	301/S SÜRME K L T (S YAH) 301/S SLIDING LOCK (BLACK)	TS45-SKS.903	1 pk / 1 ad
	05 010904	302 B ANAHTARLI SÜRME K L T (BEYAZ) 302 SLIDING LOCK WITH B KEY (WHITE)	TS45-ASK.904	1 pk / 1 ad
	05 010905	302 G ANAHTARLI SÜRME K L T (GR) 302 SLIDING LOCK WITH G KEY (GRAY)	TS45-ASK.905	1 pk / 1 ad
	05 010906	302 K ANAHTARLI SÜRME K L T (KAHVERENG) 302 SLIDING LOCK WITH K KEY (BROWN)	TS45-ASK.906	1 pk / 1 ad
	05 010907	302 S ANAHTARLI SÜRME K L T (S YAH) 302 SLIDING LOCK WITH S KEY (BLACK)	TS45-ASK.907	1 pk / 1 ad
	04 105070	S NEKL K KÖ E TAKOZ SCREENING CORNER WEDGE	TS45 - ST.070	100 ad / paket
	04 100120	S NEKL K KÖ E BA LANTI SCREENING CORNER CONNECTION	TS45-SÇ.150	4 ad / paket
	04 105018	S NEKL K HAVUZ KOL SCREENING RECESSED HANDLE	TS45-SHK.018	100 ad / paket
	04 094005	SÜRME S NEKL K RULMANI SLIDING SCREENING ROLLER	TS45-SR.17	1 pk / 100 ad
	03 020114	S NEKL K F T L SCREENING GASKET	TS45 - SF.114	100 mt / paket
	03 020115		TS45 - SF.115	
	03 020116		TS45 - SF.116	
	04 060080 - 80cm	S NEKL K TÜLÜ SCREENING NET	TS45 - STF.80	24 ² m / paket
	04 060100 - 100cm		TS45 - STF.100	30 ² m / paket
	04 060120 - 120cm		TS45 - STF.120	36 ² m / paket
	04 060140 - 140cm		TS45 - STF.140	44 ² m / paket
	04 060160 - 160cm		TS45 - STF.160	48 ² m / paket

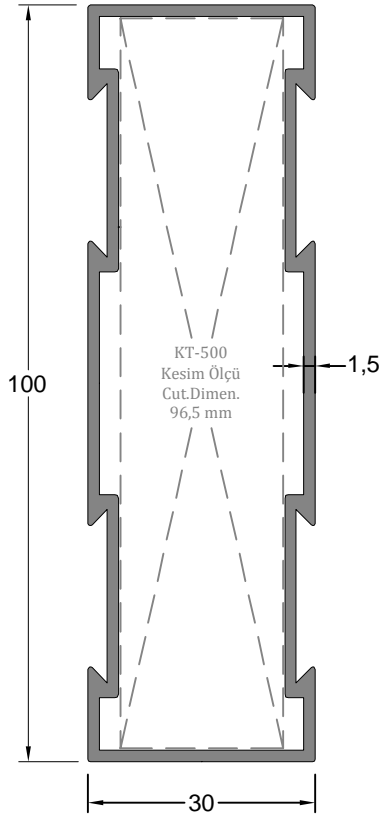

Kasa Profili	Profil Kodu	(kg/mt)
FRAME PROFILE	Profile Code	Weight
	147	1,207

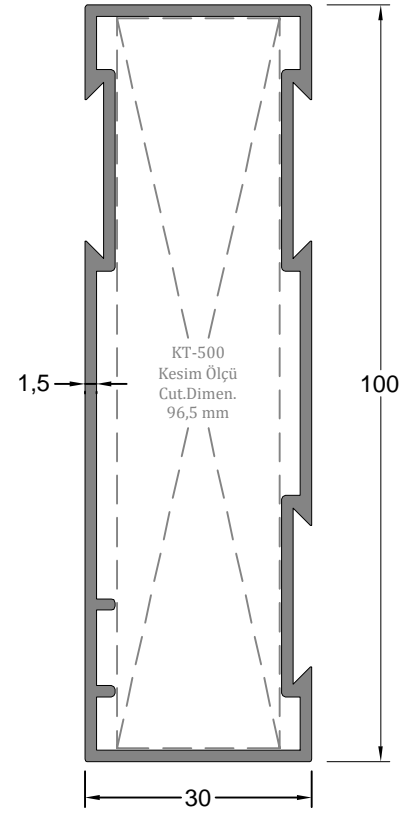

Kasa Profili	Profil Kodu	(kg/mt)
FRAME PROFILE	Profile Code	Weight
	150	1,185

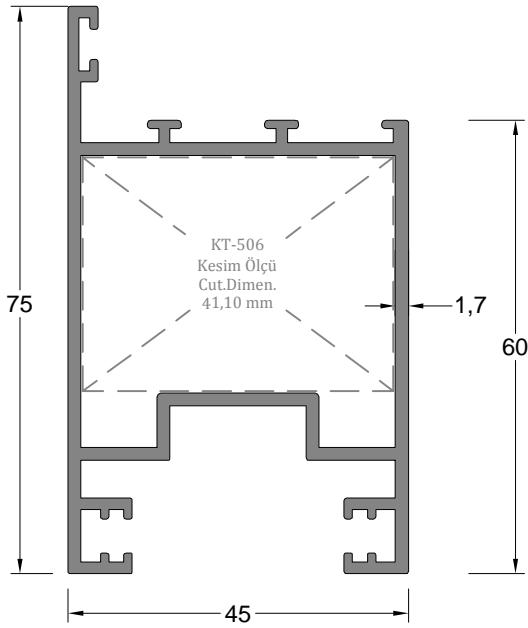

Kasa Profili	Profil Kodu	(kg/mt)
FRAME PROFILE	Profile Code	Weight
	144	1,275

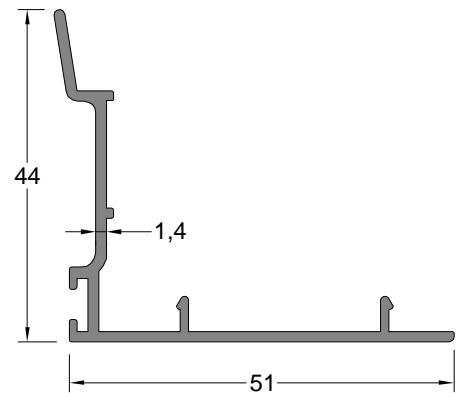

Kenet Profili	Profil Kodu	(kg/mt)
INTERLOCKING PROFILE	Profile Code	Weight
	145	0,474

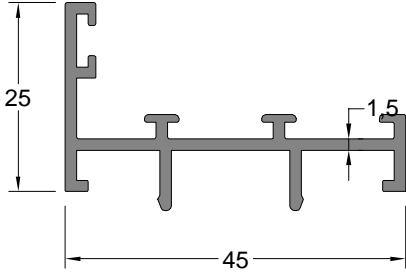

Adaptör Profili	Profil Kodu	(kg/mt)
ADAPTER PROFILE	Profile Code	Weight
	149	0,451

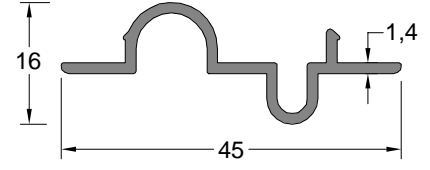

Orta Adaptör Profili	Profil Kodu	(kg/mt)
MULLION ADAPTER PROFILE	Profile Code	Weight
	146	0,272

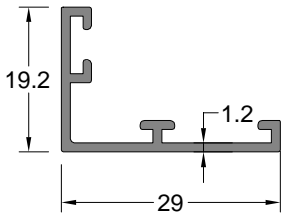

Adaptör Profili	Profil Kodu	(kg/mt)
ADAPTER PROFILE	Profile Code	Weight
	1086	0,217

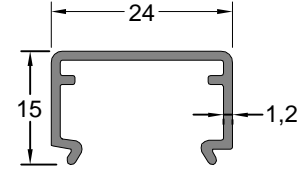

Ray Profili	Profil Kodu	(kg/mt)
RAIL PROFILE	Profile Code	Weight
	166	0,196

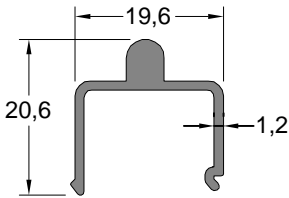

Ray Profili	Profil Kodu	(kg/mt)
RAIL PROFILE	Profile Code	Weight
	148	0,221

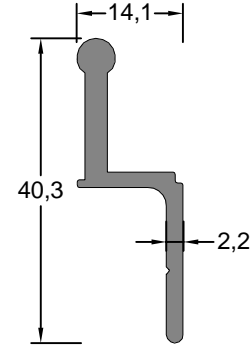

Ray Profili	Profil Kodu	(kg/mt)
RAIL PROFILE	Profile Code	Weight
	12038	0,160

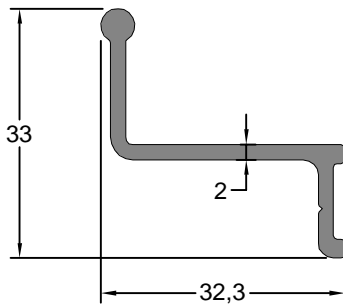

Ray Profili	Profil Kodu	(kg/mt)
RAIL PROFILE	Profile Code	Weight
	2278	0,160

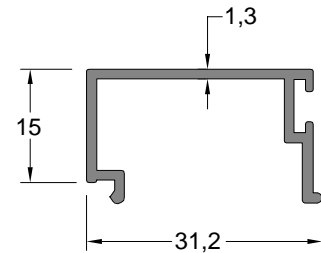

Çita Profili	Profil Kodu	(kg/mt)
BEAD PROFILE	Profile Code	Weight
	170	0,259

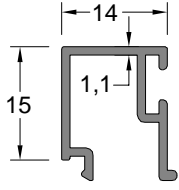

Çıta Profili	Profil Kodu	(kg/mt)
BEAD PROFILE	Profile Code	Weight
	138	0,173

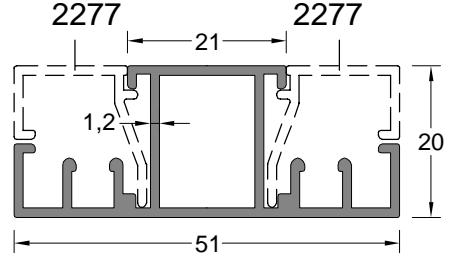

Sineklik Profili	Profil Kodu	(kg/mt)
SCREENING PROFILE	Profile Code	Weight
	12037	0,534

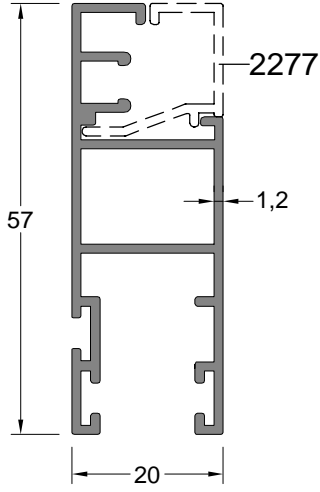

Sineklik Profili	Profil Kodu	(kg/mt)
SCREENING PROFILE	Profile Code	Weight
	2276	0,609

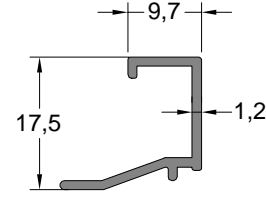

Sineklik Çıta Profili	Profil Kodu	(kg/mt)
SCREENING BEAD PROFILE	Profile Code	Weight
	2277	0,145

CAM ÇİTASI GLAZING BEAD (G)	CAM ÇİTASI UZUNLU Ğ GLAZING BEAD LENGTH (L)	Ç CAM F T L GLAZING GASKET (INSIDE) (I)	CAM KALINLI Ğ GLASS THICKNESS (T)	DI CAM F T L GLAZING GASKET (OUTSIDE) (O)
170	30 mm	CF.40	4 mm	CF.30
170	30 mm	CF.30	5 mm	CF.30
170	30 mm	CF.50	6 mm	-
170	30 mm	-	8 mm	CF.30
170	30 mm	-	10,8 mm	-
138	14 mm	CF.40	19 mm	CF.40
138	14 mm	CF.30	20 mm	CF.30
138	14 mm	-	24 mm	CF.30

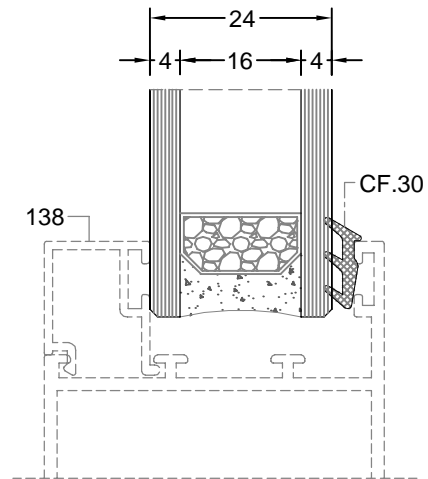
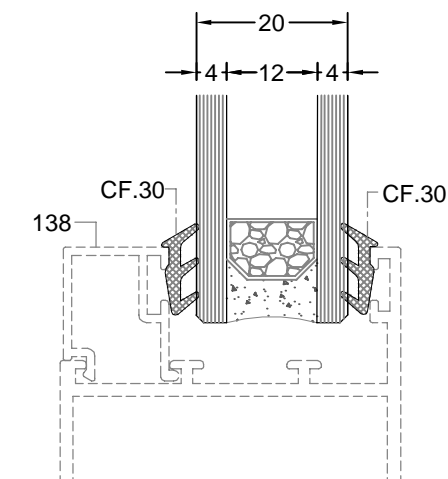
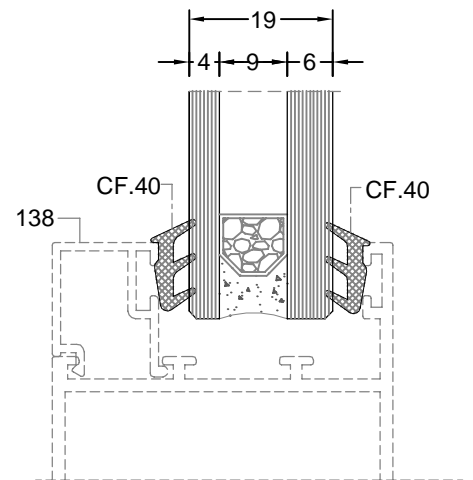
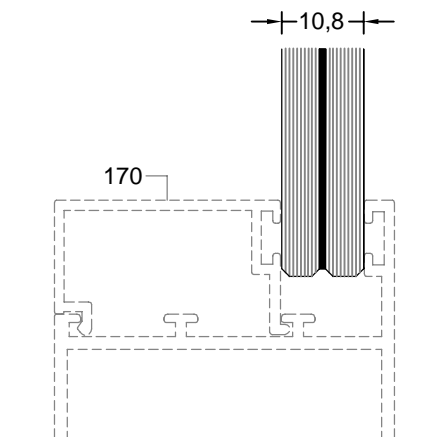
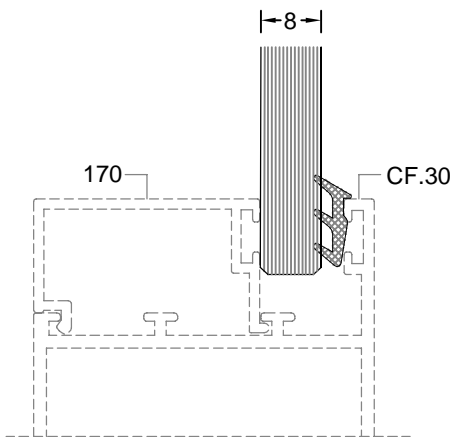
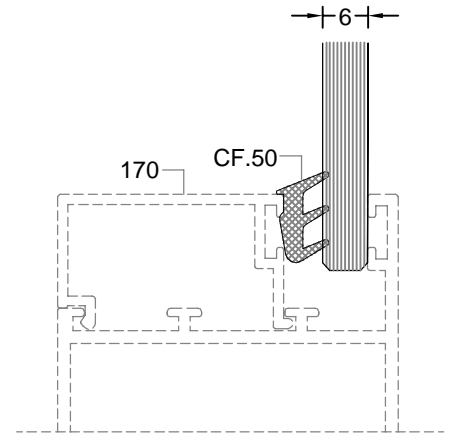
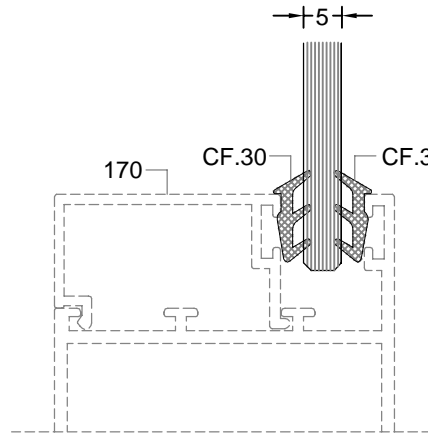
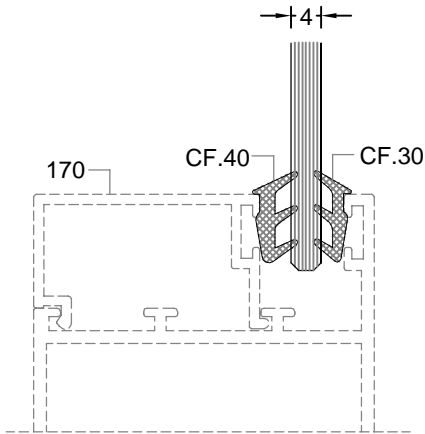
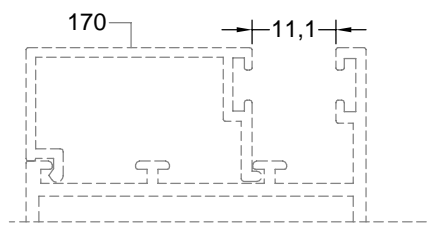
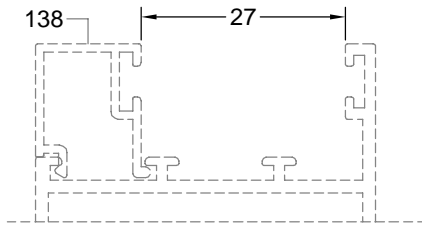

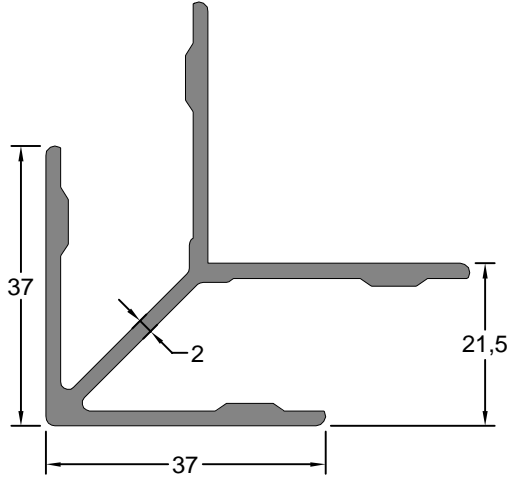

Kö e Takozu Profil Kodu Corner Wedge Profile Code	Kullanıldı ı Profil Compatible Profile	Kesim Boyu (mm) Cutting Length (mm)
500	147	96,5 mm
	150	96,5 mm

Kö e Çavuş Ba lantı Profili CORNER JOINT PROFILE	Profil Kodu Profile Code	(kg/mt) Weight
	500	0,160

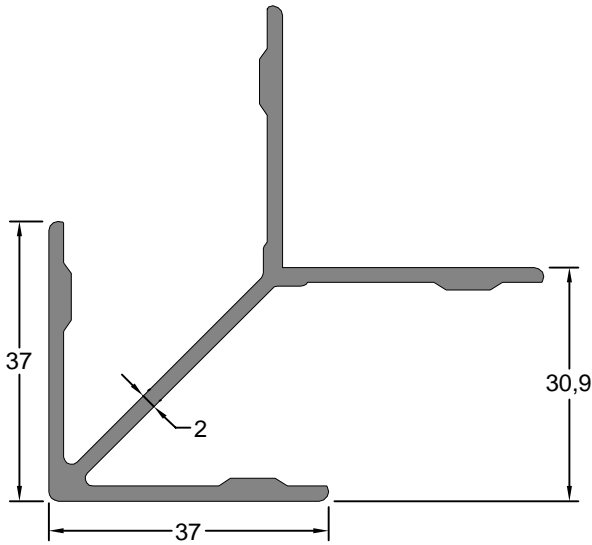

Kö e Takozu Profil Kodu Corner Wedge Profile Code	Kullanıldı ı Profil Compatible Profile	Kesim Boyu (mm) Cutting Length (mm)
506	144	41,1 mm

Kö e Çavuş Ba lantı Profili CORNER JOINT PROFILE	Profil Kodu Profile Code	(kg/mt) Weight
	506	0,160

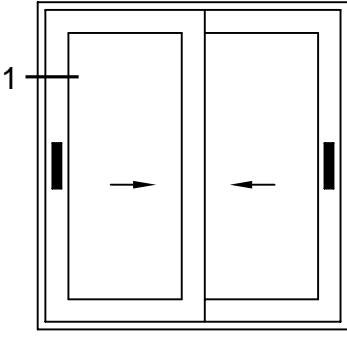

Ç
(INSIDE)

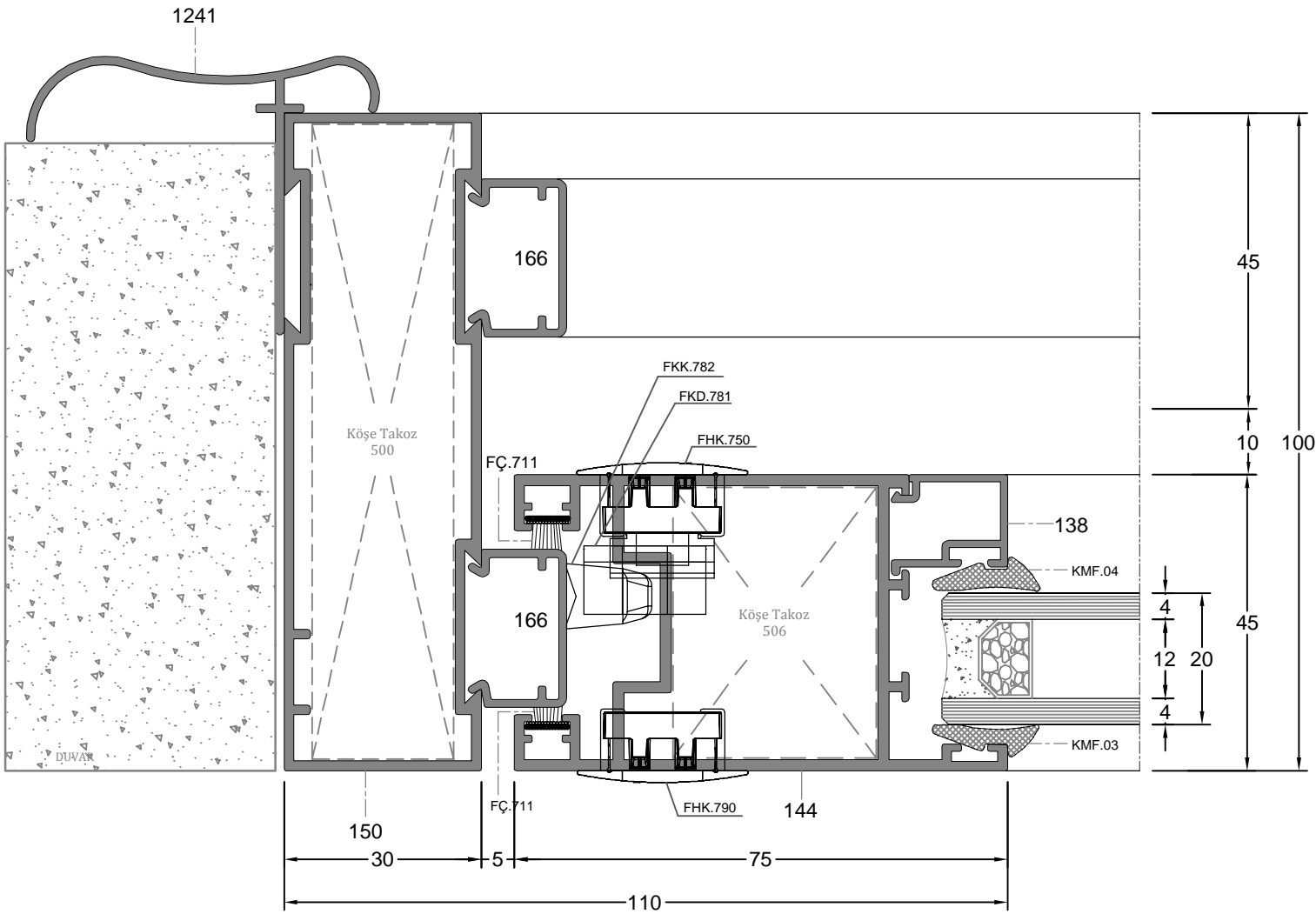

DI
(OUTSIDE)

D-1

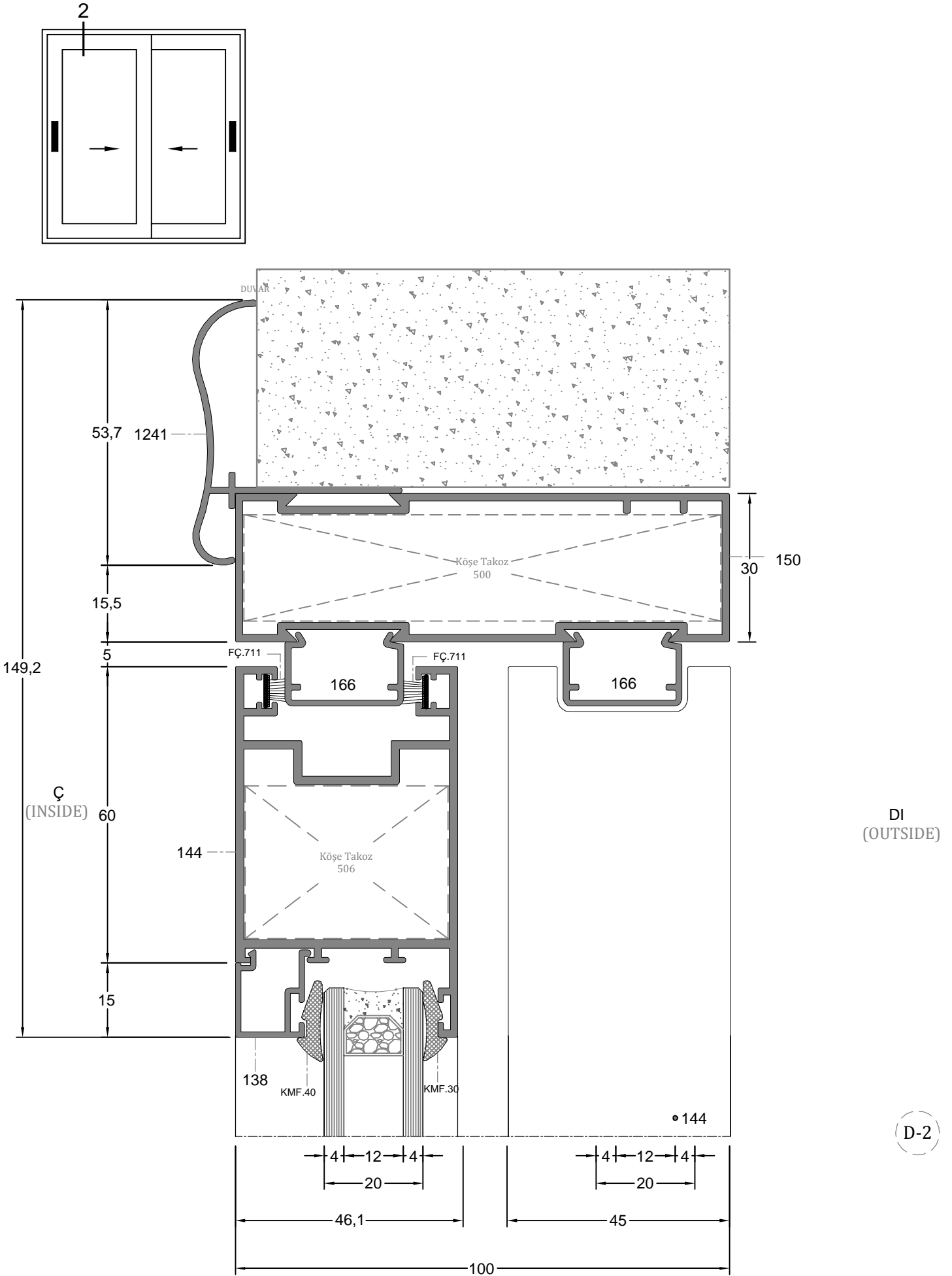

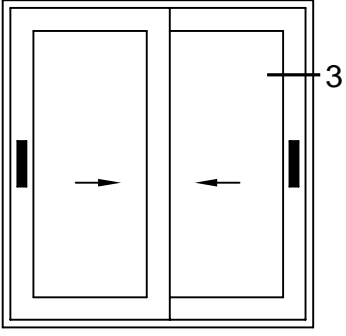

Ç
(INSIDE)

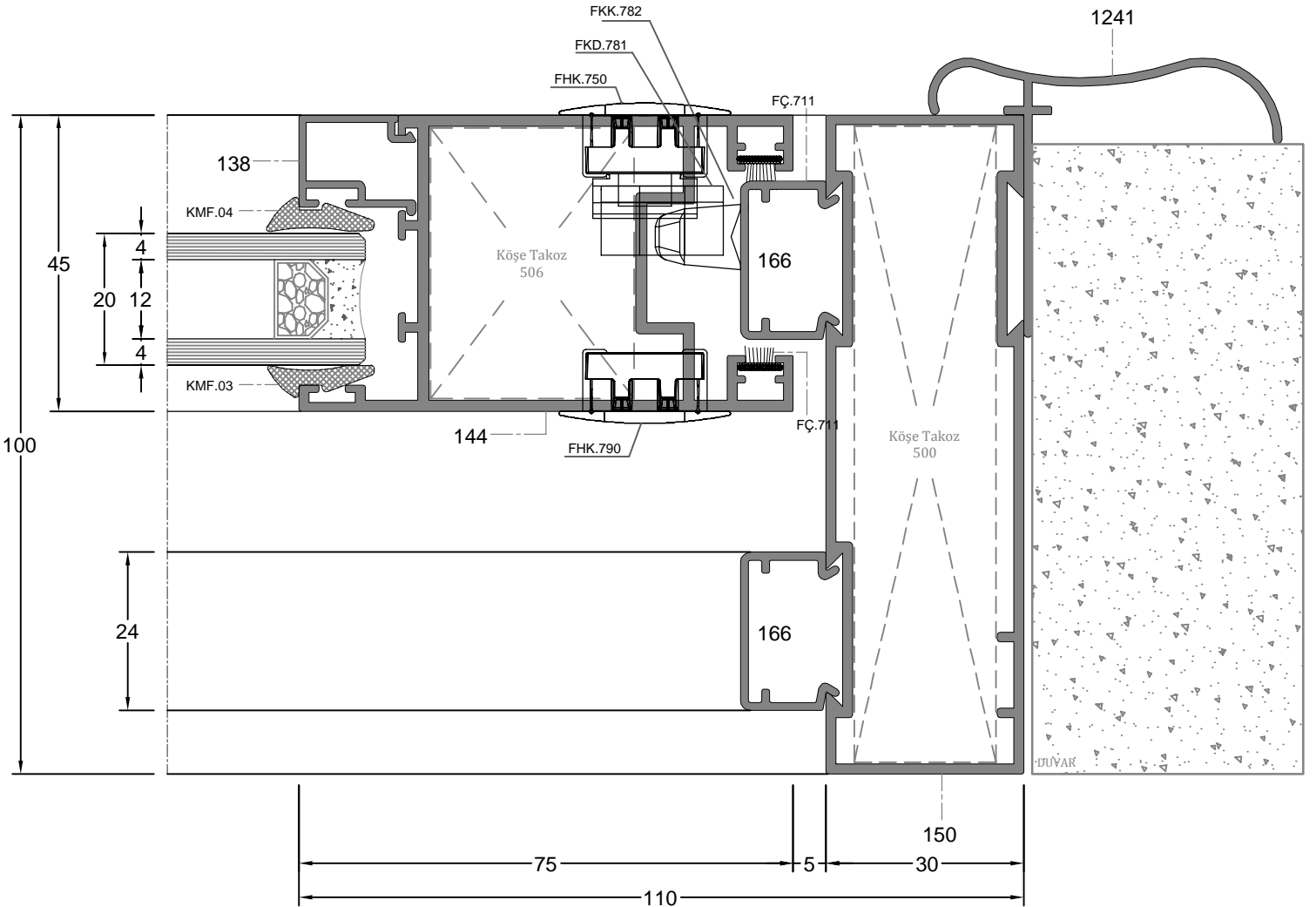

(D-3)

DI
(OUTSIDE)

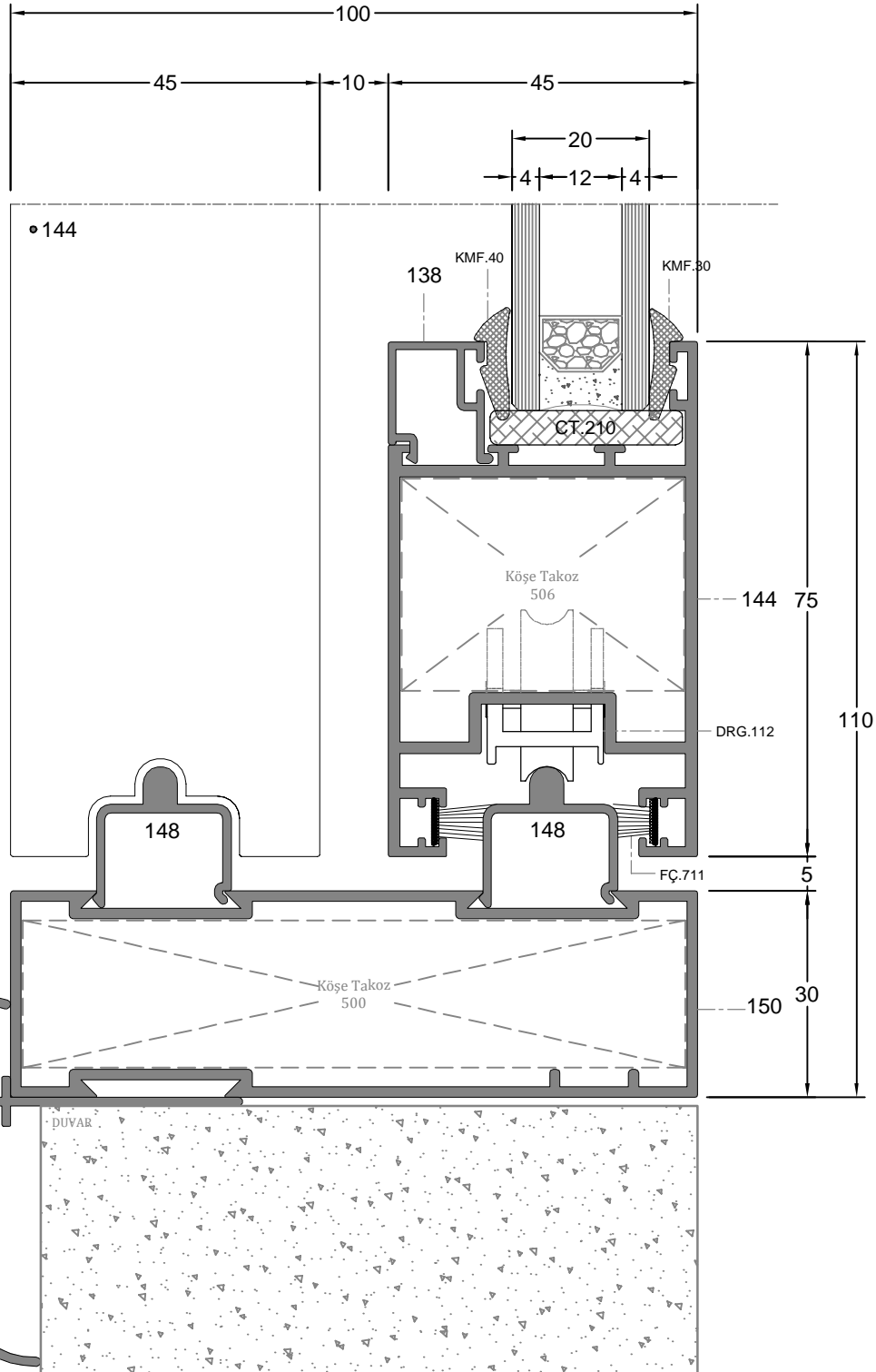
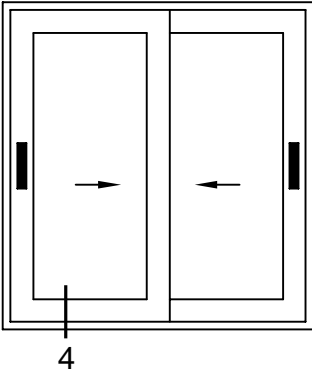

Ç
(INSIDE)

Dİ
(OUTSIDE)

D-4

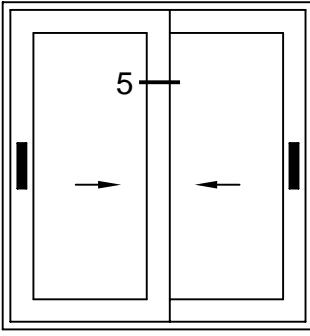

Ç
(INSIDE)

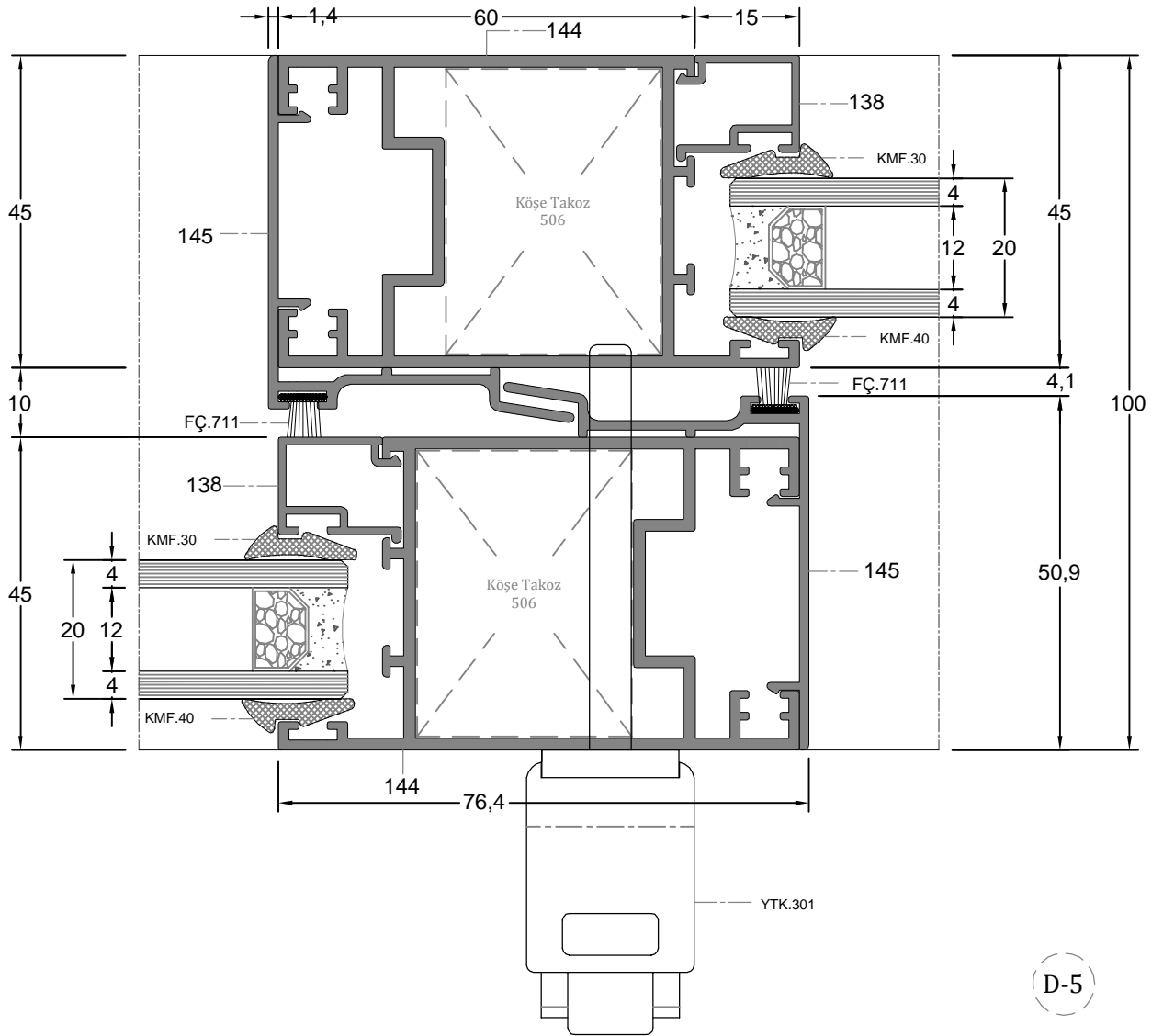

DI
(OUTSIDE)

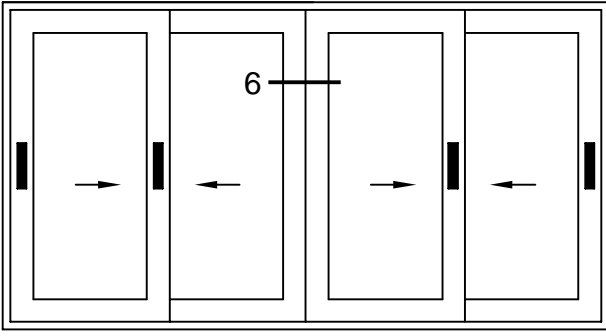

Ç
(INSIDE)

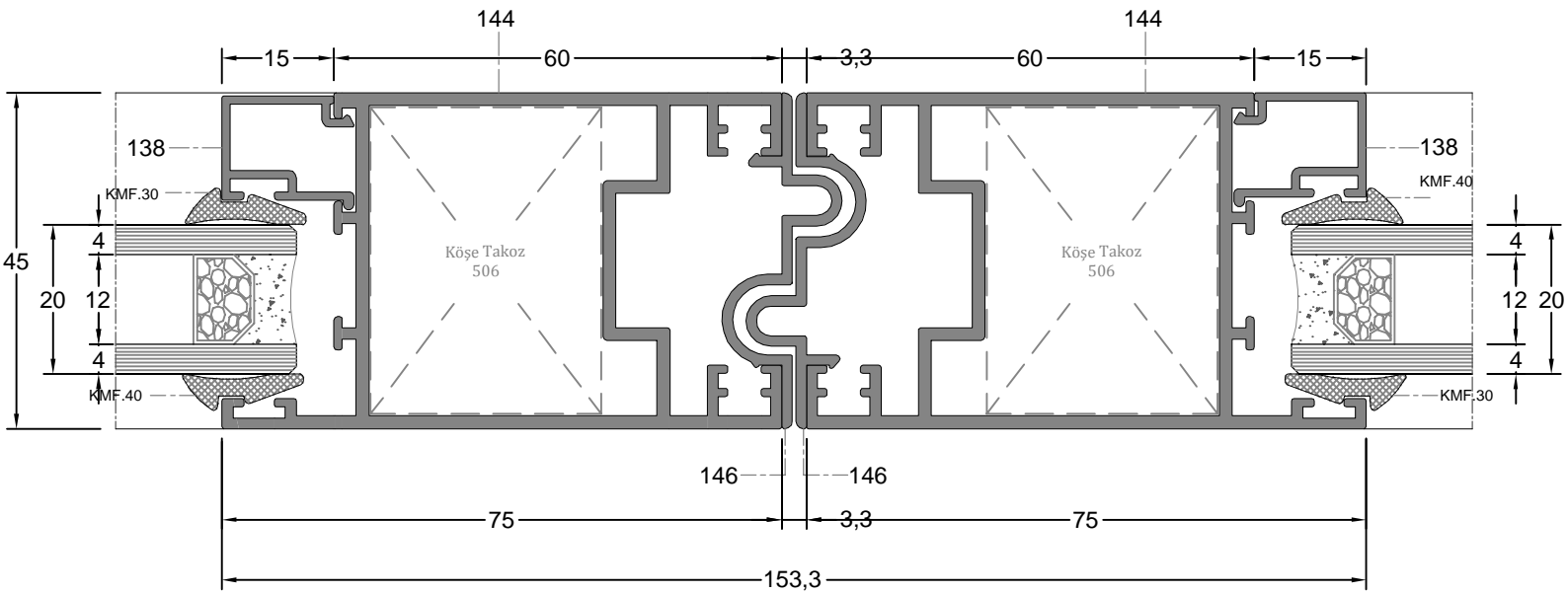

DI
(OUTSIDE)

(D-6)

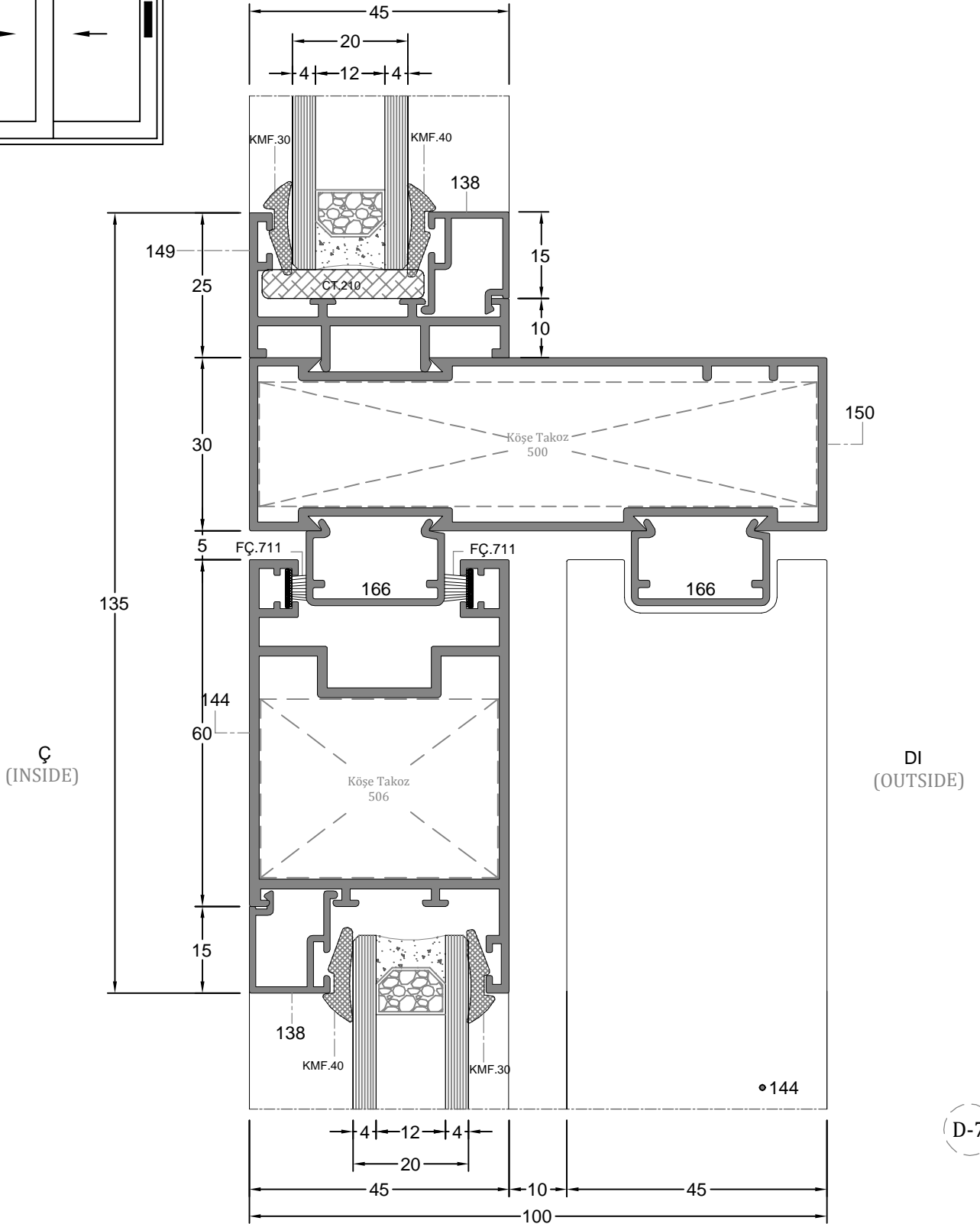
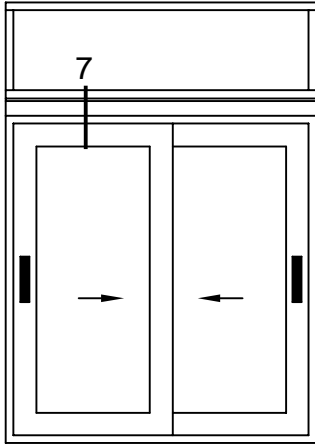

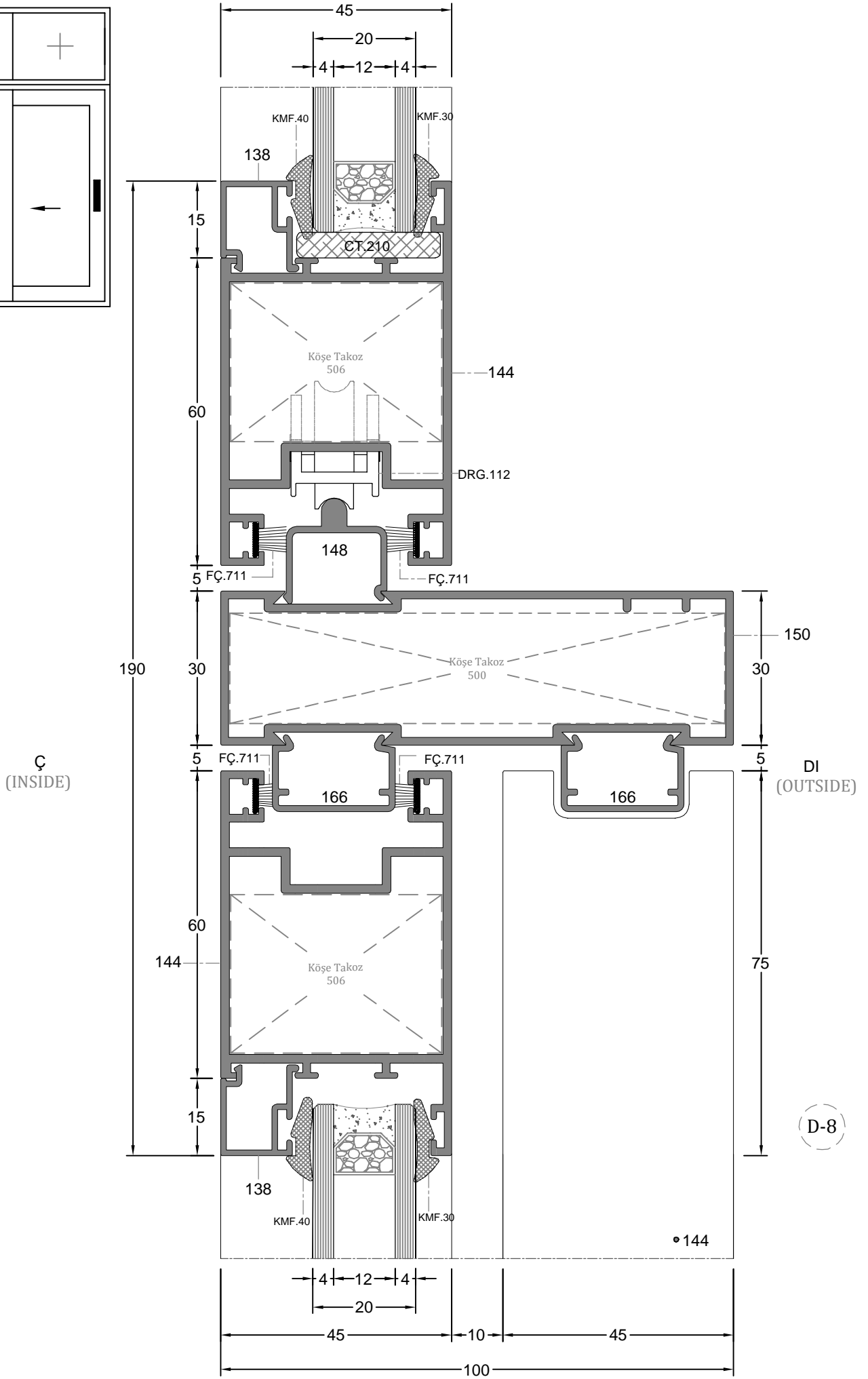
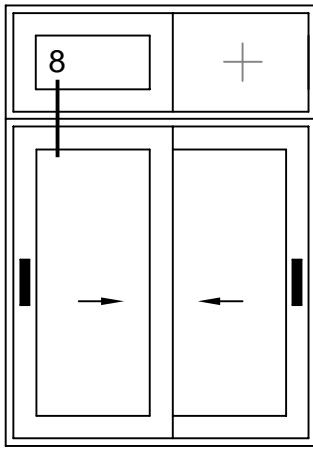

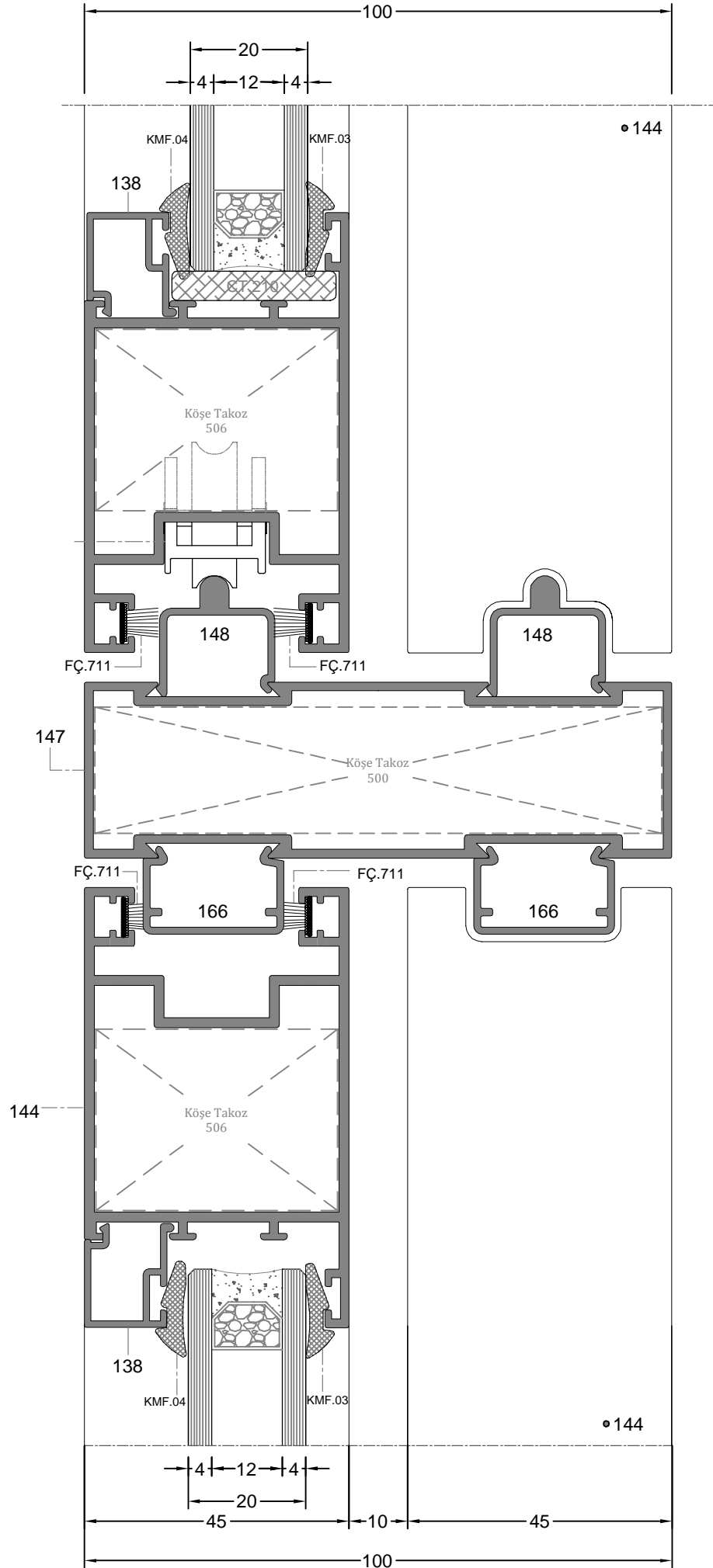
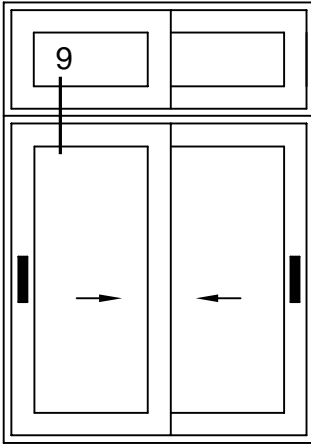

D-9

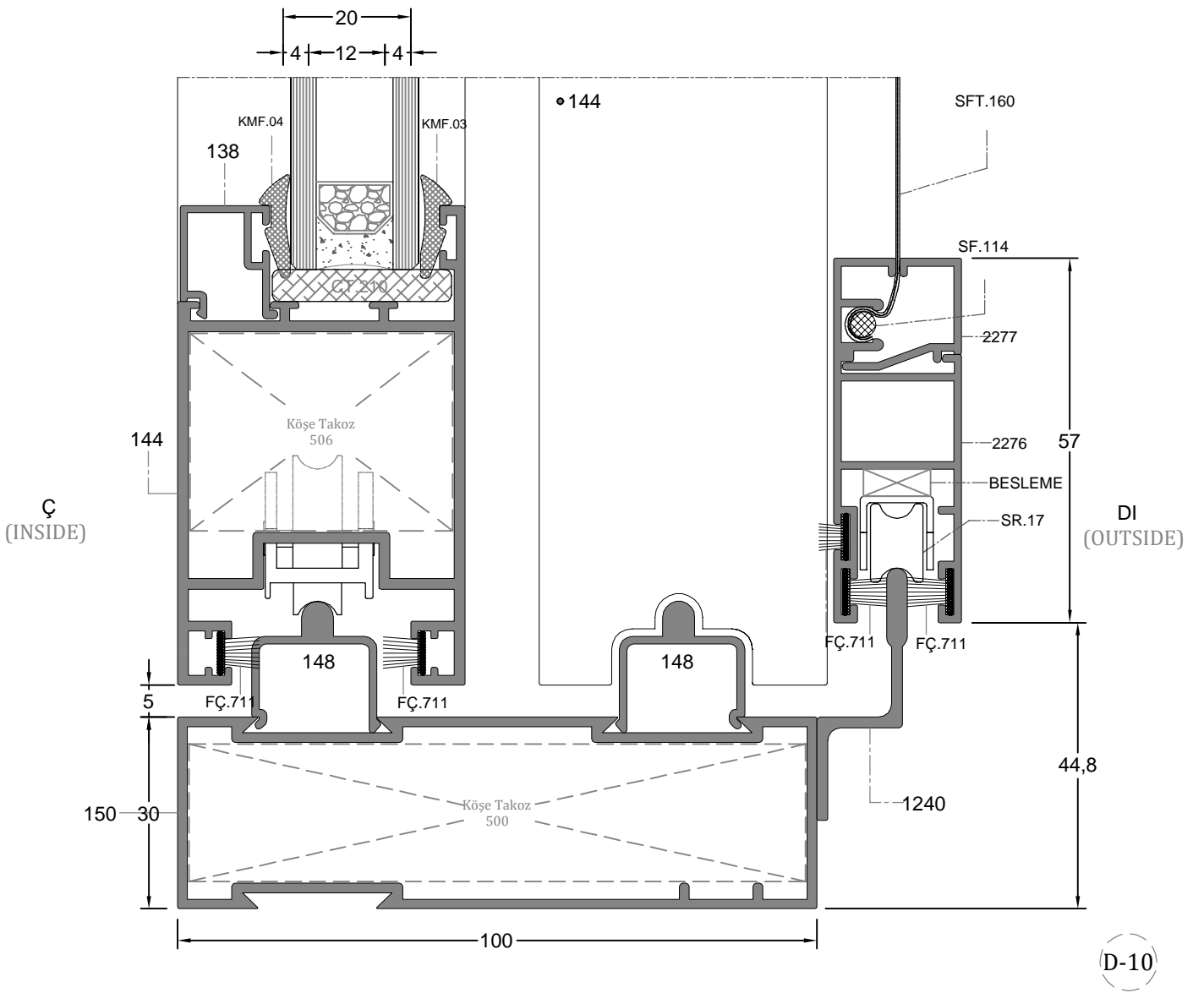
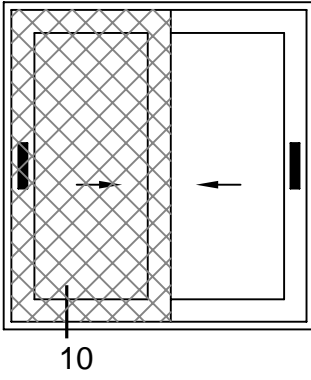

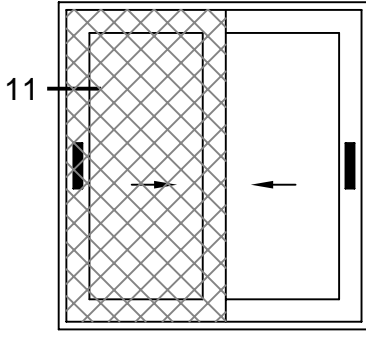

Ç
(INSIDE)

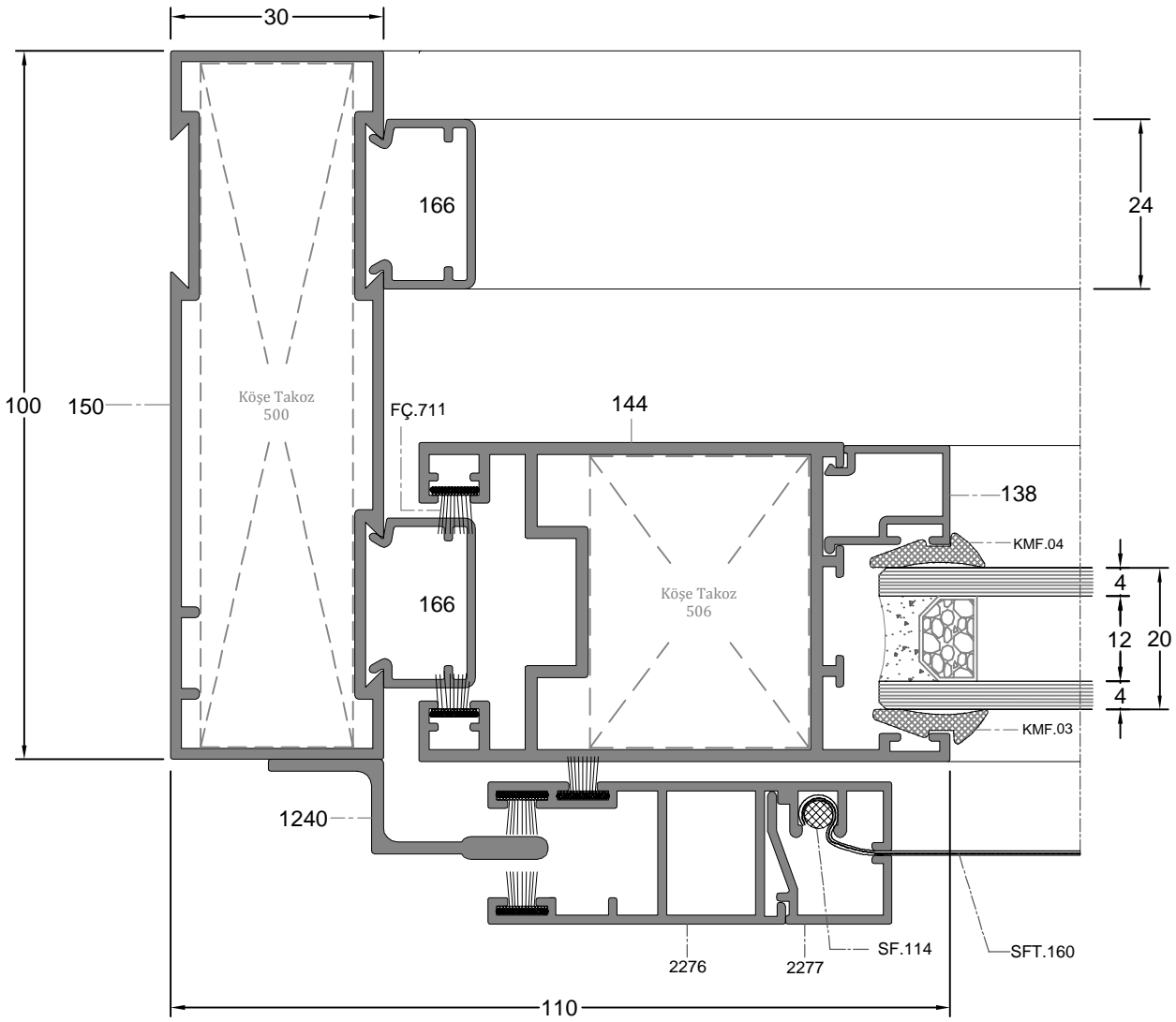

DI
(OUTSIDE)

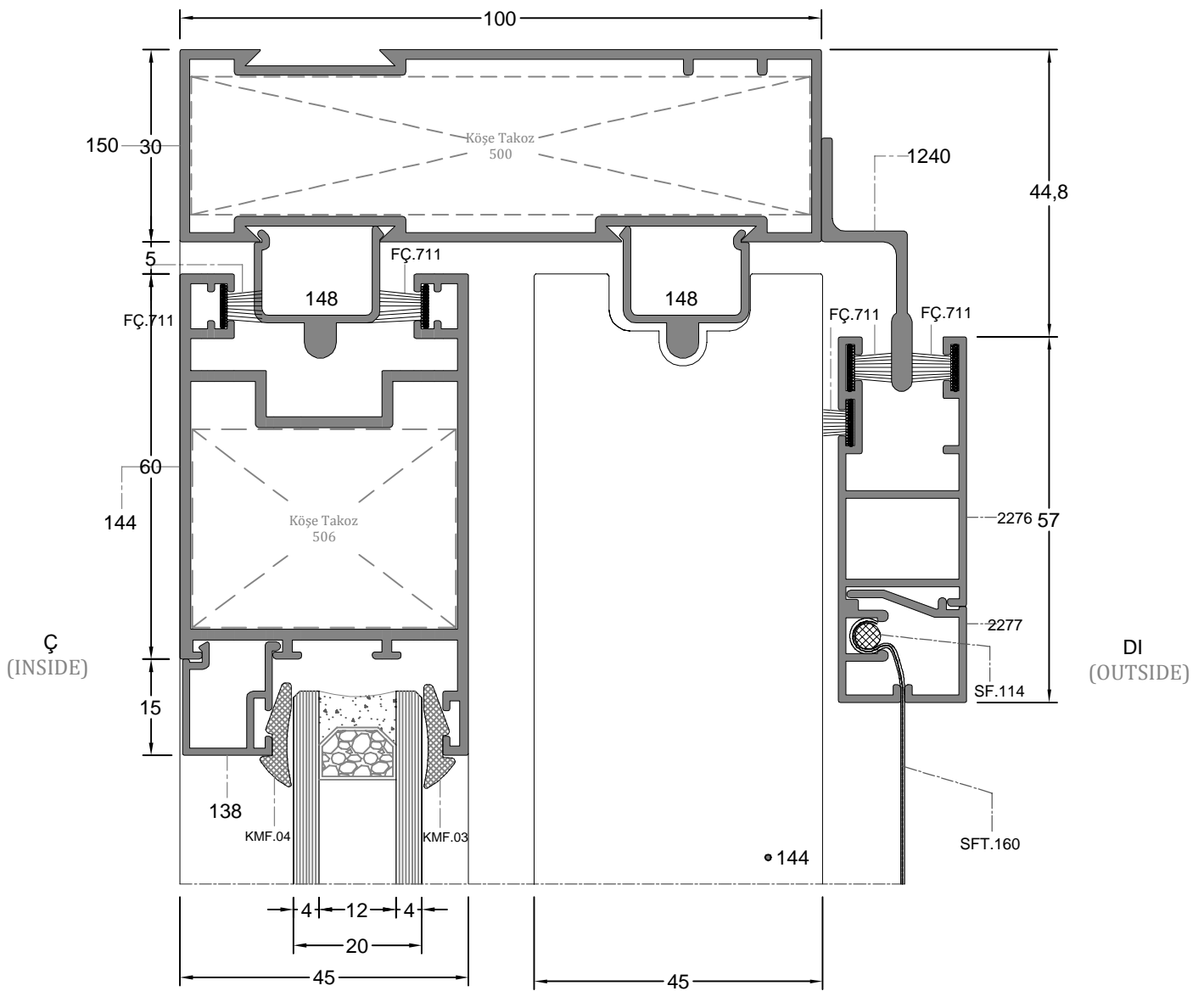
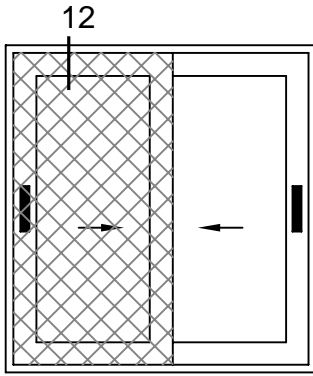

D-12

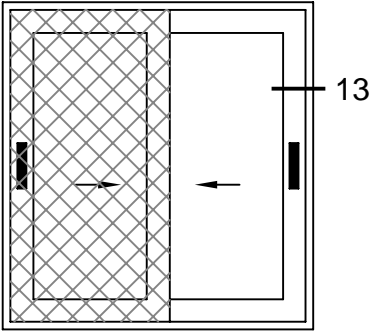

Ç
(INSIDE)

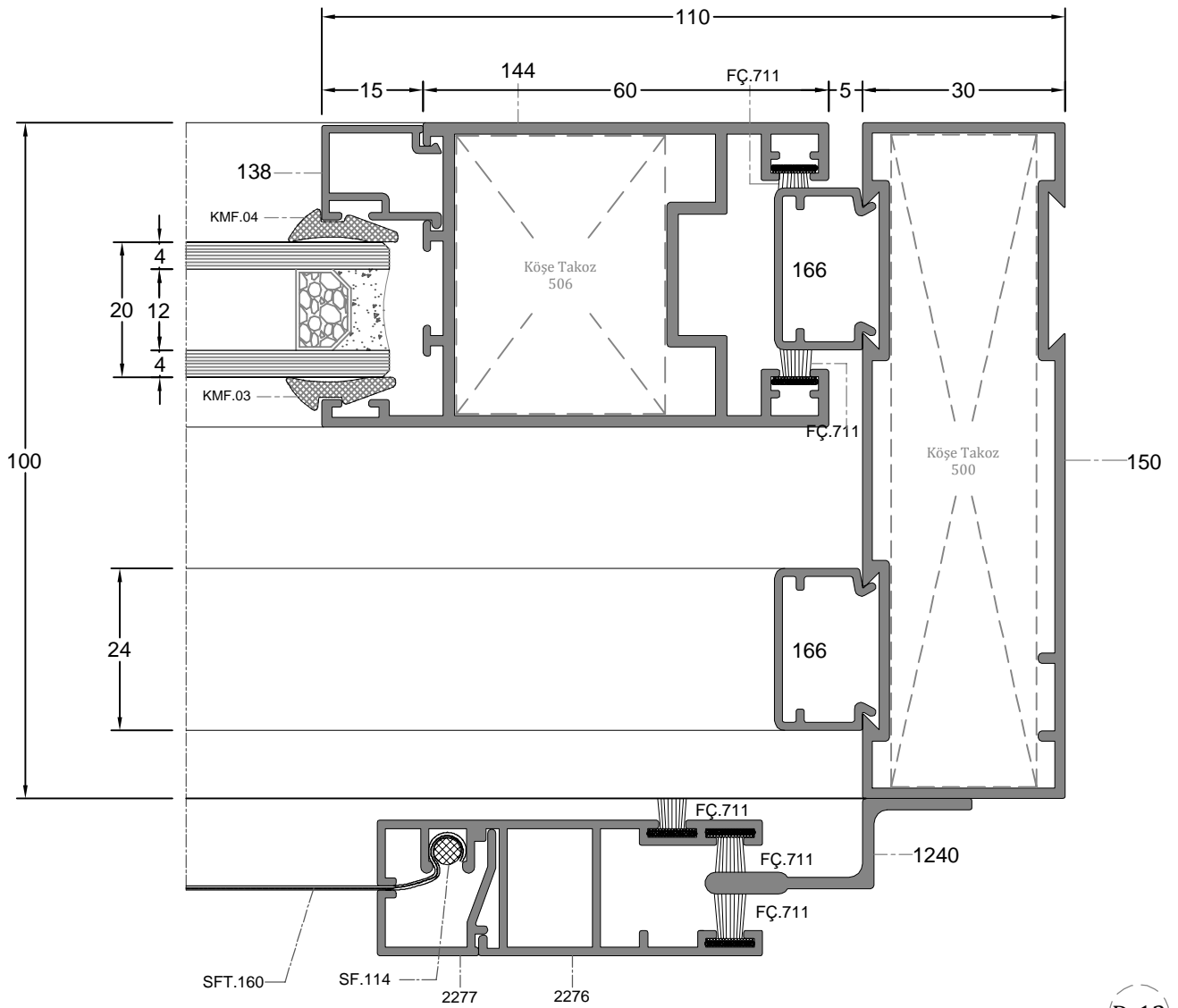

DI
(OUTSIDE)

D-13